

APPENDIX F

Geology, Soils, Mineral Resources, and Paleontological Resources

APPENDIX F1

Preliminary Geotechnical Engineering Report –
Sacramento Country Day School, White Rock Road

YOUNGDAHL
CONSULTING GROUP, INC.
1234 GLENHAVEN COURT • EL DORADO HILLS, CA 95762
PH 916.933.0633 • FX 916.933.6482 • E-mail@youngdahl.net

Sacramento Country Day School
% The FHK Companies
640 Watt Avenue, Suite 100
Sacramento, CA 95864
Attention: Mr. Fred Katz

Project No. 03293
28 August 2003

Subject: **SACRAMENTO COUNTRY DAY SCHOOL**
White Rock Road
Folsom, California
PRELIMINARY GEOTECHNICAL ENGINEERING STUDY

References: 1) *Proposal and Executed Contract for Services for Sacramento Country Day School, prepared by Youngdahl Consulting Group, Inc., project no. P03-146, dated 1 July 2003.*

Dear Mr. Katz:

In accordance with your authorization, Youngdahl Consulting Group, Inc., has performed a preliminary geotechnical engineering study for the project site located on White Rock Road in Folsom, California. The purpose of the geotechnical phase of this study was to explore and evaluate the surface and subsurface soil and rock conditions at the site and to develop generalized geotechnical information for the proposed project. Our scope for the investigation was limited to a reconnaissance level field study, laboratory testing and preparation of a preliminary geotechnical engineering study per our proposal (Reference No. 1).

Based upon our field study, subsurface exploration program, laboratory testing and engineering analysis, we believe the primary geotechnical issues to be addressed consist of limited drainage and locally expansive soil. Other geotechnical issues which are not listed above may become more apparent upon conducting a more detailed investigation and plan review once more specific development plans are complete. The descriptions, findings, conclusions and recommendations provided in this report are formulated as a whole and specific conclusions or recommendations and should not be derived or used out of context. Please review the limitations and uniformity of conditions section of this report.

This report has been prepared for the exclusive use of Sacramento Country Day School and their consultants, for specific application to this project, in accordance with generally accepted geotechnical engineering practice. Should you have any questions or require additional information, please contact our office at your convenience.

Very truly yours,
Youngdahl Consulting Group, Inc.



Keith E. Millard, R.G.
Project Geologist

Reviewed by:

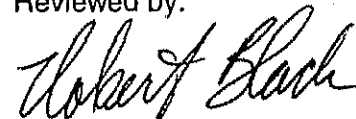

Robert F. Black, P.E.
Project Engineer

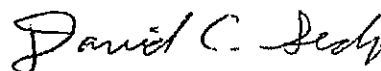

David C. Sederquist, C.E.G., C.H.G.
Senior Engineering Geologist

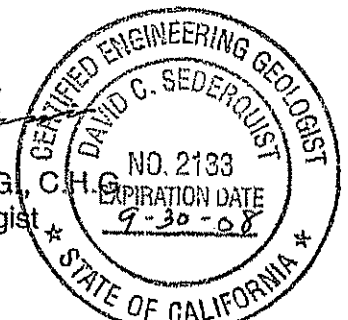
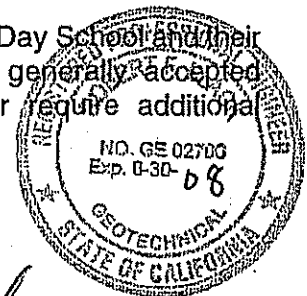

Distribution: (4) to Client

Important Information About Your

Geotechnical Engineering Report

Subsurface problems are a principal cause of construction delays, cost overruns, claims, and disputes.

The following information is provided to help you manage your risks.

Geotechnical Services Are Performed for Specific Purposes, Persons, and Projects

Geotechnical engineers structure their services to meet the specific needs of their clients. A geotechnical engineering study conducted for a civil engineer may not fulfill the needs of a construction contractor or even another civil engineer. Because each geotechnical engineering study is unique, each geotechnical engineering report is unique, prepared *solely* for the client. No one except you should rely on your geotechnical engineering report without first conferring with the geotechnical engineer who prepared it. *And no one — not even you — should apply the report for any purpose or project except the one originally contemplated.*

Read the Full Report

Serious problems have occurred because those relying on a geotechnical engineering report did not read it all. Do not rely on an executive summary. Do not read selected elements only.

A Geotechnical Engineering Report Is Based on A Unique Set of Project-Specific Factors

Geotechnical engineers consider a number of unique, project-specific factors when establishing the scope of a study. Typical factors include: the client's goals, objectives, and risk management preferences; the general nature of the structure involved, its size, and configuration; the location of the structure on the site; and other planned or existing site improvements, such as access roads, parking lots, and underground utilities. Unless the geotechnical engineer who conducted the study specifically indicates otherwise, do not rely on a geotechnical engineering report that was:

- not prepared for you,
- not prepared for your project,
- not prepared for the specific site explored, or
- completed before important project changes were made.

Typical changes that can erode the reliability of an existing geotechnical engineering report include those that affect:

- the function of the proposed structure, as when it's changed from a parking garage to an office building, or from a light industrial plant to a refrigerated warehouse,

- elevation, configuration, location, orientation, or weight of the proposed structure,
- composition of the design team, or
- project ownership.

As a general rule, *always* inform your geotechnical engineer of project changes—even minor ones—and request an assessment of their impact. *Geotechnical engineers cannot accept responsibility or liability for problems that occur because their reports do not consider developments of which they were not informed.*

Subsurface Conditions Can Change

A geotechnical engineering report is based on conditions that existed at the time the study was performed. *Do not rely on a geotechnical engineering report* whose adequacy may have been affected by: the passage of time; by man-made events, such as construction on or adjacent to the site; or by natural events, such as floods, earthquakes, or groundwater fluctuations. *Always* contact the geotechnical engineer before applying the report to determine if it is still reliable. A minor amount of additional testing or analysis could prevent major problems.

Most Geotechnical Findings Are Professional Opinions

Site exploration identifies subsurface conditions only at those points where subsurface tests are conducted or samples are taken. Geotechnical engineers review field and laboratory data and then apply their professional judgment to render an opinion about subsurface conditions throughout the site. Actual subsurface conditions may differ—sometimes significantly—from those indicated in your report. Retaining the geotechnical engineer who developed your report to provide construction observation is the most effective method of managing the risks associated with unanticipated conditions.

A Report's Recommendations Are *Not* Final

Do not overrely on the construction recommendations included in your report. *Those recommendations are not final*, because geotechnical engineers develop them principally from judgment and opinion. Geotechnical engineers can finalize their recommendations only by observing actual

subsurface conditions revealed during construction *The geotechnical engineer who developed your report cannot assume responsibility or liability for the report's recommendations if that engineer does not perform construction observation*

A Geotechnical Engineering Report Is Subject to Misinterpretation

Other design team members' misinterpretation of geotechnical engineering reports has resulted in costly problems. Lower that risk by having your geotechnical engineer confer with appropriate members of the design team after submitting the report. Also retain your geotechnical engineer to review pertinent elements of the design team's plans and specifications. Contractors can also misinterpret a geotechnical engineering report. Reduce that risk by having your geotechnical engineer participate in prebid and preconstruction conferences, and by providing construction observation.

Do Not Redraw the Engineer's Logs

Geotechnical engineers prepare final boring and testing logs based upon their interpretation of field logs and laboratory data. To prevent errors or omissions, the logs included in a geotechnical engineering report should never be redrawn for inclusion in architectural or other design drawings. Only photographic or electronic reproduction is acceptable, *but recognize that separating logs from the report can elevate risk*

Give Contractors a Complete Report and Guidance

Some owners and design professionals mistakenly believe they can make contractors liable for unanticipated subsurface conditions by limiting what they provide for bid preparation. To help prevent costly problems, give contractors the complete geotechnical engineering report, *but* preface it with a clearly written letter of transmittal. In that letter, advise contractors that the report was not prepared for purposes of bid development and that the report's accuracy is limited; encourage them to confer with the geotechnical engineer who prepared the report (a modest fee may be required) and/or to conduct additional study to obtain the specific types of information they need or prefer. A prebid conference can also be valuable. *Be sure contractors have sufficient time to perform additional study.* Only then might you be in a position to give contractors the best information available to you, while requiring them to at least share some of the financial responsibilities stemming from unanticipated conditions.

Read Responsibility Provisions Closely

Some clients, design professionals, and contractors do not recognize that geotechnical engineering is far less exact than other engineering disciplines. This lack of understanding has created unrealistic expectations that

have led to disappointments, claims, and disputes. To help reduce the risk of such outcomes, geotechnical engineers commonly include a variety of explanatory provisions in their reports. Sometimes labeled "limitations" many of these provisions indicate where geotechnical engineers' responsibilities begin and end, to help others recognize their own responsibilities and risks. *Read these provisions closely.* Ask questions. Your geotechnical engineer should respond fully and frankly.

Geoenvironmental Concerns Are Not Covered

The equipment, techniques, and personnel used to perform a *geoenvironmental* study differ significantly from those used to perform a *geotechnical* study. For that reason, a geotechnical engineering report does not usually relate any geoenvironmental findings, conclusions, or recommendations; e.g., about the likelihood of encountering underground storage tanks or regulated contaminants. *Unanticipated environmental problems have led to numerous project failures.* If you have not yet obtained your own geoenvironmental information, ask your geotechnical consultant for risk management guidance. *Do not rely on an environmental report prepared for someone else.*

Obtain Professional Assistance To Deal with Mold

Diverse strategies can be applied during building design, construction, operation, and maintenance to prevent significant amounts of mold from growing on indoor surfaces. To be effective, all such strategies should be devised for the *express purpose* of mold prevention, integrated into a comprehensive plan, and executed with diligent oversight by a professional mold prevention consultant. Because just a small amount of water or moisture can lead to the development of severe mold infestations, a number of mold prevention strategies focus on keeping building surfaces dry. While groundwater, water infiltration, and similar issues may have been addressed as part of the geotechnical engineering study whose findings are conveyed in this report, the geotechnical engineer in charge of this project is not a mold prevention consultant; *none of the services performed in connection with the geotechnical engineer's study were designed or conducted for the purpose of mold prevention. Proper implementation of the recommendations conveyed in this report will not of itself be sufficient to prevent mold from growing in or on the structure involved.*

Rely on Your ASFE-Member Geotechnical Engineer for Additional Assistance

Membership in ASFE/THE BEST PEOPLE ON EARTH exposes geotechnical engineers to a wide array of risk management techniques that can be of genuine benefit for everyone involved with a construction project. Confer with you ASFE-member geotechnical engineer for more information.



8811 Colesville Road/Suite G106, Silver Spring, MD 20910

Telephone: 301/565-2733 Facsimile: 301/589-2017

e-mail: info@asfe.org www.asfe.org

Copyright 2004 by ASFE, Inc. Duplication, reproduction, or copying of this document, in whole or in part, by any means whatsoever, is strictly prohibited, except with ASFE's specific written permission. Excerpting, quoting, or otherwise extracting wording from this document is permitted only with the express written permission of ASFE, and only for purposes of scholarly research or book review. Only members of ASFE may use this document as a complement to or as an element of a geotechnical engineering report. Any other firm, individual, or other entity that so uses this document without being an ASFE member could be committing negligent or intentional (fraudulent) misrepresentation.

TABLE OF CONTENTS

| | | |
|------------|---|----|
| 1.0 | INTRODUCTION | 1 |
| 1.1 | Purpose and Scope | 1 |
| 2.0 | PROJECT DESCRIPTION | 1 |
| 3.0 | SITE DESCRIPTION | 1 |
| 3.1 | Background | 1 |
| 3.2 | Surface Observations | 2 |
| 3.3 | Subsurface Exploration | 2 |
| 3.4 | Subsurface Conditions | 2 |
| 3.5 | Geologic Conditions | 3 |
| 3.6 | Laboratory Testing | 4 |
| 4.0 | CONCLUSIONS | 4 |
| 5.0 | RECOMMENDATIONS | 6 |
| 5.1 | General | 6 |
| 5.2 | Site Preparation | 7 |
| 5.3 | Engineered Fills | 8 |
| 5.4 | Slope Grading | 9 |
| 5.5 | Finish Soilgrade Preparation | 10 |
| 5.6 | Drainage Considerations | 10 |
| 5.7 | Seismic Design Criteria | 10 |
| 6.0 | LIMITATIONS AND UNIFORMITY OF CONDITIONS | 12 |
| APPENDIX A | | 14 |
| | Field study | 15 |
| | Vicinity Map (Figure A-1) | 16 |
| | Site Plan (Figure A-2) | 17 |
| | Conceptual Site Plan (Figure A-2a) | 18 |
| | Logs of Exploratory Pits (Figures A-3 through A-39) | 19 |
| | Soil Classification Chart and Pit Log Legends (Figure A-40) | 45 |
| APPENDIX B | | 47 |
| | Laboratory Testing | 48 |
| | Expansion Index Test (Figure B-1) | 49 |
| | Atterberg Limit Tests (Figures B-2 and B-3) | 50 |
| | Modified Proctor Tests (Figures B-4 and B-5) | 52 |
| APPENDIX C | | 54 |

PRELIMINARY GEOTECHNICAL ENGINEERING STUDY
for
SACRAMENTO COUNTRY DAY SCHOOL
White Rock Road
Folsom, California

1.0 INTRODUCTION

This report presents the results of our Preliminary Geotechnical Engineering Study performed for the proposed Sacramento Country Day School planned to be constructed north of White Rock Road near Scott Road in Folsom, California. Refer to Figure A-1 for a vicinity map for the project site.

1.1 Purpose and Scope

The purpose of this study was to explore and evaluate the surface and subsurface conditions at the site and to develop geotechnical information and design criteria for the proposed project. The scope of this study includes the following:

1. A review of geotechnical and geologic data available to us at the time of our study.
2. A field study consisting of a visual site reconnaissance, followed by an exploratory test pit program to characterize the subsurface conditions.
3. A laboratory testing program performed on representative samples collected during our field study.
4. Engineering analysis of the data and information obtained from our field study, laboratory testing, and literature review. Development of recommendations for site preparation and grading.
5. Preparation of this report summarizing our findings, conclusions, and recommendations regarding the geotechnical aspects for the project.

2.0 PROJECT DESCRIPTION

As a result of the preliminary nature of this investigation, full development plans were not provided to us. Instead, a conceptual illustration indicates a middle and elementary school project which will eventually include 10 buildings, a swimming pool, track and field, multiple athletic courts and fields and associated utilities and pavements. The project is to be built over a period of about 10 to 20 years in three phases.

For the purpose of this report, we have assumed that grading operations will consist of cuts and fills on the order of 25 feet or less and that foundation loads will be light to moderate. Once specific building plans and foundation loads become available, we recommend a more detailed level of investigation to include specific design criteria.

3.0 SITE DESCRIPTION

3.1 Background

Review of our records indicates that the project site has likely been used for ranching through present day. Some limited mining exploration is evidenced by possible prospect pits on the subject property. If studies or plans exist that pertain to the site which aren't cited as a reference in this



report, we should be afforded the opportunity to review and modify our conclusions and recommendations as necessary.

3.2 Surface Observations

The project site is located on the north side of White Rock Road between Scott Road and Prairie City Road, in Folsom, California. It is roughly square in shape and encompasses 80 acres. The north, west and east sides are bounded by undeveloped ranch land, and White Rock Road forms the southern boundary. Topography is hummocky with minor drainages along the site's western edge and rises roughly 25 feet over a north-south trending series of hills just west of center. Continuing eastward, topography falls roughly 40 feet to cross a northward-running drainage then rises again roughly 15 feet onto rolling terrain along the eastern edge. Site relief totals 57 feet from the top of a knoll in the northwestern quarter to where a drainage exits the northeast quarter. Existing structures are limited to a small corral in the southeast corner. Vegetation includes many large oak trees on the western half of the site and a dense growth of grasses and weeds elsewhere. An incised drainage in the southwestern quarter, shaded by large oak trees, also supports several smaller trees and bushes. Dormant remains of small flowering plants were observed in vernal pools throughout the site.

3.3 Subsurface Exploration

Our field study included a site reconnaissance by a Youngdahl Consulting Group, Inc., representative followed by a subsurface exploration program conducted on 9 through 11 July 2003, which included the excavation of 37 test pits (20 geotechnical, 10 for septic design, 7 for geology/groundwater) under his direction at the approximate locations shown on Figure A-2, Appendix A. Excavation of the test pits was accomplished with a John Deere 310SG rubber tire-mounted backhoe equipped with 18 and 24 inch wide buckets. Bulk and bag samples were collected from the pits. The test pits were not backfilled with engineered fills and will require re-excavation and compaction of the soils during site development. Refer to Appendix B for a more detailed description of the subsurface exploration procedure.

3.4 Subsurface Conditions

Subsurface conditions at the site can be summarized into three categories. The southwestern half of the site is comprised primarily of very light brown silty SAND in a loose and dry state to depths of 2 to 5 feet underlain by orange silty SAND with a trace of clay and gravel in a slightly cemented medium dense to dense and dry to wet state to depths approaching 8 feet. A few test pits encountered light brown poorly graded SAND with a trace of silt in a medium dense and slightly moist to wet state below the silty SANDs and extending to the maximum depth of exploration. A few others, in the northwest and southeast corners of the site, found the surficial silty SANDs to be underlain at depths of 3 to 5 feet by GABBRO BEDROCK decomposed to residual soil with slight moisture and density increasing with depth. Much of the northeastern half of the site is underlain by gray to black SLATE BEDROCK, highly to moderately weathered, indurated, and with well developed foliation and fracturing. Numerous outcrops penetrated the surface and soil overburden was typically 6 to 8 inches thick. Finally, the hill in the north-central portion of the site revealed red brown sandy CLAY in a hard and dry to slightly moist state to depths of 6 to 8 feet underlain by brown poorly graded SAND with a trace of silt in a medium dense and slightly moist to moist state to the maximum depth of exploration.

Free groundwater was not encountered during our explorations. However, subsurface water conditions typically vary in the foothill region. Our experience in the area shows that water may be



perched on and present in the fractures of the weathered bedrock found beneath the site at varying times of the year as is evidenced by the presence of vernal pools.

A more detailed description of the subsurface conditions encountered is presented graphically on the "Exploratory Test Pit Logs", Figures A-3 through A-39, presented in Appendix A. These logs show a graphic interpretation of the subsurface profile and the location and depths at which samples were collected.

3.5 Geologic Conditions

The geologic portion of this report included a review of geologic data pertinent to the site, and an interpretation of our observations and the Logs of Exploratory Test Pits excavated during the field study.

The project site is situated along the eastern edge of Sacramento County, at the base of the foothills of the Sierra Nevada geomorphic province. Tectonic building during the late Triassic and much of the Jurassic resulted from oceanic and island masses subducting under or accreting onto the continental land mass and thereby caused extensive mountain formation. At the same time, large amounts of soil and rock were eroded off the mountains and deposited in the adjoining deep marine basins, which today comprise the Great Valley sedimentary beds and includes the greater Sacramento area flatlands.

Faults in the province, which generally strike northwest and dip eastward, were typically generated by either collision or subduction between the ancient oceanic and continental plate masses. These faults are represented in the local region by the Mormon Island Shear Zone, the east and west branches of the Bear Mountains Fault Zone, and the Foothills-Melones Fault Zone. All of these fault systems are considered only potentially active, with the last fault movement on any of these systems estimated to have occurred a minimum of 50 thousand to 2 million years before present (CDMG, GDM-6, 1994). The Mormon Island Shear Zone roughly trends along the Sacramento County line in the Folsom area, approximately 3 miles east of the site, and the West Branch of the Bear Mountains Fault is mapped about 5 miles to the northeast in El Dorado Hills roughly paralleling El Dorado Hills Boulevard. The Foothill-Melones Fault Zone is located 16 miles to the east of the site in the Placerville area.

According to the California Division of Mines and Geology map for the Folsom 15-minute quadrangle (OFR 84-50, Plate I, 1984), the subject site spans a geologic contact between metamorphic slate related to the Late Jurassic island arc Salt Springs Formation to the east and igneous gabbro related to the Mesozoic Foothill Melange-Ophiolite Terrane to the west. Perched atop this contact in the hill in the north-central portion of the site is an eroded remnant of alluvial sediments related to the Tertiary age Laguna Formation. Rock outcrops at the site consisted of steeply dipping, metamorphic slate bedrock. The slate is generally foliated, fractured and weathered in a manner that lends itself to excavatability. The onsite soils are derived mainly from weathering of the underlying igneous gabbro bedrock, the Salt Springs slate, and sedimentary Laguna Formation and consist mainly of silty sands, sands and clayey sands.

Strong earthquakes generated along any northern California or western Nevada active faults may affect the site, depending on the characteristics of the earthquake and the location of the epicenter (CDMG, OFR 96-08, 1996). Maximum horizontal acceleration predicted for the site from regional active faults and regional potentially active faults would be on the order of 0.2g and 0.3g,



respectively (CDMG, OFR 96-08, 1996). In general, the effects will be confined to those phenomena associated with shaking and/or acceleration and will be minimized by adequate design and construction procedures. Based on the soil properties and topography of the site, there is no reasonable danger from earthquake-induced liquefaction or landsliding. The new 1998 edition of the California Building Code classifies the site as being within the Zone 3 seismic region. Based on our subsurface interpretations, the eastern portion of the site, underlain by slate bedrock, is classified as Soil Profile Type S_B . The remainder of the site, underlain by soil, is classified as Soil Profile Type S_C . Seismic coefficients of 0.30 (for Soil Profile Type S_B) and 0.45 (for Soil Profile Type S_C) and a near source factor of 1.0 for acceleration and velocity are applicable to the site.

Asbestos Assessment: Due to the site's geologic conditions, sampling and testing were performed to evaluate if naturally occurring asbestos is present in the soil and underlying rock in a manner which could potentially result in a health risk during construction. Six samples, representative of the near-surface soils, were collected and submitted to an accredited laboratory for asbestos testing by California Air Resources Board Test Method 435 (ARB TM 435). Asbestos was not detected in these samples. Laboratory results are presented in Appendix C.

3.6 Laboratory Testing

The laboratory testing of collected samples was directed towards determining the physical and engineering properties of the soils underlying the site. A description of the tests performed and their results are presented in Appendix B.

4.0 CONCLUSIONS

We offer the following general geotechnical conclusions concerning this development project.

Site Suitability: The native soils and rock, processed and compacted as recommended below, are considered suitable for support of the planned improvements, pending review of specific foundation plans.

Expansive Soils: We encountered low expansive soils at depths of 0 to 6 feet in Test Pits TP-8 through TP-10 and TP-24 through TP-29. These expansive soils can cause moderate distress to structural improvements if present within the upper 3 feet of grade. Expansive soils can shrink and swell with changes of moisture content resulting in structural distress of improvements supported on these materials. Improvement areas should be mitigated as described in the recommendations section of this report. A review of grading plans should be performed prior to mass grading operations to determine the extent of mitigation measures required.

Groundwater: At the time of excavation (9 July 2003), free groundwater was not encountered in our explorations. However, subsurface water conditions typically vary in the foothill region. Our experience in the area shows that water may be encountered in the fractured and weathered rock found beneath the site at varying times of the year, and shallow or perched groundwater levels probably occur during the winter and spring months as evidenced by the presence of vernal pools. At all times of the year, groundwater levels would likely fluctuate in response to precipitation patterns and site utilization.

A perched water table often develops in shallow bedrock and cemented soil horizons as surface water percolates down through the surface soils and perches on top of the relatively impermeable horizon. The perched water can saturate surface soils. Saturated soils may be unstable under



construction equipment, and may require considerable aeration in order to achieve a moisture content which will allow compaction. The prospect of saturated soils should be considered in construction scheduling. Water inflow into any excavation approaching hard rock surface is likely to be experienced in all but the driest summer and fall months.

Following site development, additional water sources (ie. landscape watering, downspouts) are generally present. The presence of low permeability materials can prohibit rapid dispersion of surface and subsurface water drainage. Utility trenches typically provide a conduit for water distribution. Provisions may be necessary to mitigate adverse effects of perched water conditions. Mitigation measures may include the construction of cut-off systems and/or plug and drain systems. Close coordination between the design professionals regarding drainage and subdrainage conditions may be warranted.

Subdrainage: Building pads or pavement areas constructed in cut which approach the weathered bedrock or cemented soil horizon may require subdrainage measures. Such measures may include an increase in the crushed rock capillary break and/or installation of subdrain trenches beneath or around the building pads and/or design pavement section. Youngdahl Consulting Group, Inc. should review the final development plans, when available, to obtain a preliminary indication of where subdrainage may be required. Subdrainage requirements should be based on our observation of building pad and pavement areas following grading, but may also be necessary following future development of areas adjacent to, or on the property.

Excavation: The test pits were excavated using a John Deere 310SG backhoe equipped with an 18 inch wide bucket. The degree of difficulty encountered in excavating our test pits is an indication of the effort that will be required for excavation during construction. Based on our test pits, we expect that the site soils can be excavated using conventional earthmoving equipment such as a Caterpillar D6 to D8 for mass grading and rubber tired backhoe for trench excavations. The underlying rock materials can likely be excavated using a Caterpillar D8 equipped single or multiple shank rippers, or similar equipment. We anticipate that a ripper equipped D8 can penetrate at least as deep as our test pits at most locations with moderate effort. Deeper excavation into the less weathered rock may require heavier equipment, such as a D9, or a D10.

Where rock cuts in fractured rock are proposed, the orientation and direction of ripping will likely play a large role in the rippability of the material. If hard rock is encountered, we should be contacted to provide additional recommendations prior to performing an alternative such as blasting.

Utility trenches will likely encounter hard rock excavation conditions especially in deeper cut areas. Utility contractors should be prepared to use special rock trenching equipment such as rock wheel excavators or large excavators such as a CAT 235 or CAT 245. Water inflow into any excavation approaching a hard rock surface is likely to be experienced in all but the driest summer and fall months. Pre-ripping during mass grading may be beneficial and should be considered with the Geotechnical Engineer prior to, or during mass grading.

Liquefaction: Liquefaction is the sudden loss of soil shear strength and sudden increase in porewater pressure caused by shear strains, as could result from an earthquake. Research has shown that saturated, loose to medium-dense sands with a silt content less than about 25 percent located within the top 40 feet are most susceptible to liquefaction. Due to the absence of a



permanent elevated groundwater table, the relatively low seismicity of the area, the relatively shallow depth to bedrock, the potential for site liquefaction is considered negligible.

Slope Stability: The project site is proposed to have minor cuts and fill with a maximum slope orientation of 2H:1V (horizontal:vertical). Generally a cut slope orientation of 2H:1V is considered stable with the material types encountered on the site. A fill slope constructed at the same orientation is considered stable if compacted to the engineered fill recommendations as stated in the recommendations section of this report. All slopes should have appropriate drainage and vegetation measures to minimize erosion of slope soils.

The existing slopes on the project site were observed to have adequate vegetation on the slope face, appropriate drainage away from the slope face, and no apparent tension cracks or slump blocks in the slope face or at the head of the slope.

Steeper fill slope gradients may be achievable through the use of geotextile materials to strengthen and/or provide erosion protection. Surficial stability of steeper cut slopes may be achievable due to the geology of the cut materials. Steepening of slopes greater than 2H:1V will require design and observation during the proposed cut and/or fill. Any slope excavations proposed to be greater than 10 feet in maximum height should be evaluated during and prior to completion of site grading.

Seismic Considerations: Based on our literature review and subsurface interpretations, we recommend that the project be designed in accordance with the latest applicable California Building Code (CBC), Chapter 16. This site is located within Seismic Risk Zone 3. Based on our subsurface interpretations, the eastern portion of the site, underlain by slate bedrock, is classified as Soil Profile Type S_B . The remainder of the site, underlain by soil, is classified as Soil Profile Type S_C .

5.0 RECOMMENDATIONS

5.1 General

Based on our preliminary exploration, the site is suitable for the proposed improvements provided the recommendations presented in this report are incorporated into the project plans and specifications.

All grading, foundation, and landscape drainage plans should be reviewed by Youngdahl Consulting Group, Inc., hereinafter described as the Geotechnical Engineer, prior to contract bidding. A review should be performed to determine whether the recommendations contained within this report are incorporated into the project plans and specifications.

Our recommendations are based on limited windows into the subsurface conditions. Additional exploration, based on planned structure locations and loads, should be performed in order to develop specific geotechnical design criteria. Field observation and testing during the grading operations should be provided by the Geotechnical Engineer so that an opinion may be formed regarding the adequacy of the site preparation, the acceptability of fill materials, and the extent to which the earthwork construction and the degree of compaction comply with the project geotechnical specifications. Any work related to grading performed without the full knowledge of, and under direct observation by the Geotechnical Engineer may render the conclusions and recommendations of this report invalid.



Section 3317.8 in Appendix Chapter 33 of the latest California Building Code states that, in regard to the transfer of responsibility, if the Geotechnical Engineer of Record for the project site is not maintained through the grading phase of the project, the work shall be stopped until the replacement has agreed in writing to accept their responsibility within the area of technical competence for approval upon completion of the work. Our design recommendations should not be relied upon without our consultation, observation and testing services during all aspects of grading on the site.

We recommend that the applicable chapters of the latest edition of the CBC be adhered to during the design and construction of the proposed structures.

5.2 Site Preparation

Preparation of the project site should involve temporary drainage, dust control, demolition, clearing, stripping, existing fills, subgrade compaction, differential support conditions, and groundwater considerations. The following paragraphs state our geotechnical comments and recommendations concerning site preparation.

Temporary Drainage: We recommend that initial site preparation involve intercepting and diverting any potential sources of surface or near-surface water within the construction zones. Because the selection of an appropriate drainage system will depend on the water quantity, season, weather conditions, construction sequence, and contractor's methods, final decisions regarding drainage systems are best made in the field at the time of construction. All drainage and/or water diversion performed for the site should be in accordance with the Clean Water Act and applicable Storm Water Pollution Prevention Plan.

Dust Control: Dust control provisions should be provided for as required by the local jurisdiction's grading ordinance (i.e. water truck or other adequate water supply during grading).

Demolition: As part of a demolition operation, any and all unwanted foundation and structural improvement elements should be exhumed and removed from the site. In addition, any underground storage tanks, abandoned wells or other utilities not intended for reuse should be removed or backfilled in accordance with the appropriate regulations.

Concrete and asphalt separated from the other debris, and adequately broken down in particle size, may be mixed thoroughly with native soils and placed as engineered fill as described below. If this option is exercised, a representative from our firm should be contacted to observe the adequacy of grading operations associated with the breaking and mixing of these elements.

Clearing and Stripping: Clearing and stripping operations should remove all organic laden materials including trees, bushes, root balls, root systems, and any soft or loose material generated from removal operations. Surface grass stripping operations may be necessary depending upon the in-situ conditions at the time of mass grading. Short or mowed dry grasses may be pulverized and lost within fill materials provided no concentrated pockets of organics result. It is the responsibility of the grading contractor to remove excess organics from the fill materials. No more than 2 percent of organic material, by weight, should be allowed within the fill materials at any given location.

General site clearing should also include removal of any loose or saturated materials from the proposed structural improvement and pavement areas. A representative of our firm should be



present during site clearing operations to identify the location and depth of potential fills not disclosed by this report, to observe removal of deleterious materials, and to identify any existing site conditions which may require mitigation prior to site development. Preserved trees may require tree root protection which should be addressed on an individual basis by a qualified arborist.

Existing Fills: Although not encountered during our subsurface exploration, all fills and fill stockpiles, if encountered, should be over-excavated down to firm native materials. Any depressions extending below final grade resulting from the removal of fill materials or other deleterious materials should be properly prepared as discussed below and backfilled with engineered fill. Prior to placement of engineered fill, the exposed soil surfaces receiving fills should be scarified to a minimum depth of 8 inches, moisture conditioned as necessary, and compacted to at least 90 percent of the maximum dry density based on the ASTM D1557 test method. Additionally, test pits should be re-excavated and backfilled with engineered fill.

If existing fills were placed and documented as engineered fill materials, a review of the appropriate documentation should be performed.

Exposed Grade Compaction: Exposed soil grades following initial site preparation activities should be scarified to a minimum depth of 8 inches and compacted to the requirements for engineered fill. Prior to placing fill, the exposed subgrades should be in a firm, unyielding state. Any localized zones of soft or pumping soils observed within a subgrade should either be scarified and recompact or be overexcavated and replaced with engineered fill as defined below in Section 5.3.

Differential Support Conditions: During preparation of this preliminary report, specific structure or grading plans were not available for our review. Differential support conditions may be a concern where fills are placed and compacted for construction of a building pad and the proposed building will span from a native to deep fill condition. In order to mitigate the potential for differential settlement, overexcavation of the cut portion of the building pad, deepening of the foundations, or adjustment of compaction requirements may be recommended. We should be afforded the opportunity to review the construction plans in order to develop site specific recommendations regarding differential conditions.

Groundwater Considerations: Due to the nature of the soils encountered in the area of the project site, we anticipate that a perched groundwater table and/or water bearing fractures in bedrock may be encountered during the winter or spring seasons. Where cuts are proposed, subdrains may need to be installed to catch water flowing along the soil/bedrock contact, cemented soil contact, or through the fractured rock.

Swales and natural hillside drainage proposed to receive engineered fill may require the installation of a canyon style drain. Close coordination between the design professionals for placement and discharge of canyon style drains should be performed.

5.3 Engineered Fills

All materials placed as fills on the site should be placed as "Engineered fill" observed and compacted as described in the following paragraphs.



On-site Soils: We expect that soil generated from excavations on the site, excluding deleterious material, may be used as engineered fill.

Fill Placement and Compaction: All areas proposed to receive fill should be scarified to a minimum depth of 8 inches, moisture conditioned as necessary, and compacted to at least 90 percent of the maximum dry density based on the ASTM D1557 test method. The fill should be placed in thin horizontal lifts not to exceed 12 inches in uncompacted thickness. The fill should be moisture conditioned as necessary and compacted to a relative compaction of not less than 90 percent based on the ASTM D1557 test method. The upper 8 inches of fills placed under proposed pavement areas should be compacted to a relative compaction of not less than 95 percent based on the ASTM D1557 test method. Expansive clays, if encountered, should not be placed within the upper three feet of building pad and subgrade level. Alternatively, clays may be mixed thoroughly with less expansive on site materials (silts, sands, and gravels). Proper disposition of clays on site should be verified by a representative of Youngdahl Consulting Group, Inc.

Compaction of Expansive Soils: If clays are the predominate component of the soil in the upper 3 feet of the proposed building pads, they should be addressed as a potentially expansive material and compacted using a different approach as stated above. Expansive clays should be compacted to 88 to 92 percent of the maximum dry density based on the ASTM D1557 test method at a moisture content of about 4 percent over optimum. If expansive clay fills thicker than 5 feet are proposed, supplemental compaction recommendations may be necessary.

Subgrade Verification and Compaction Testing: Fill soil compaction should be verified by means of in-place density tests performed during fill placement so that adequacy of soil compaction efforts may be evaluated as earthwork progresses.

Soil Moisture Considerations: The near-surface fine grained soils may become partially or completely saturated during the rainy season. Grading operations during this time period may be difficult since compaction efforts may be hampered by saturated materials. It is, therefore, suggested that consideration be given to the seasonal limitations and costs of winter grading operations on the site.

5.4 Slope Grading

Placement of Fills on Slopes: Placement of fill material on natural slopes should be stabilized by means of keyways and benches. Where the slope of the original ground equals or exceeds 5H:1V, a keyway should be constructed at the base of the fill. The keyway should consist of a trench excavated to a depth of at least two feet into firm, competent materials. The keyway trench should be at least eight feet wide or as designated by the Geotechnical Engineer. Benches should be cut into the original slope as the filling operation proceeds. Each bench should consist of a level surface excavated at least six feet horizontally into firm soils or four feet horizontally into rock. The rise between successive benches should not exceed 36 inches. The need for subdrainage should be evaluated at the time of construction.

Slope Face Compaction: All slope fills should be laterally overbuilt and cut back such that the required compaction is achieved at the proposed finish slope face. As a less preferable alternative,



the slope face could be tracked walked or compacted with a wheel. If this second alternative is used, additional slope maintenance may be necessary.

Slope Drainage: Surface drainage should not be allowed to flow uncontrolled over any slope face. Adequate surface drainage control should be designed by the project civil engineer in accordance with the latest applicable edition of the CBC. All slopes should have appropriate drainage and vegetation measures to minimize erosion of slope soils.

Cut/Fill Transition: When grading operations result in a transition from cut to fill on a lot, special grading recommendations may be required depending upon the actual cuts and fills. Youngdahl Consulting Group, Inc. should be afforded the opportunity to review each individual pad grading plan to determine if special grading recommendations are required.

5.5 Finish Soilgrade Preparation

Finish building pad soilgrades should be compacted to at least 90 percent of the maximum dry density as determined by ASTM D1557 test method. Pavement subgrades compacted to at least 95 percent of the maximum dry density as determined by ASTM D1557 test method and should be proof-rolled with a full water truck or equivalent immediately before paving, in order to verify their condition.

5.6 Drainage Considerations

Special attention should be given regarding the drainage of the project site. If the project is expected to work through the wet season, the contractor should install appropriate temporary drainage systems at the construction site and should minimize traffic over exposed subgrades due to the moisture-sensitive nature of the on-site soils. If the project improvements are constructed prior to the wet season, but are not proposed to be fine graded for permanent drainage until the next dry season, temporary drainage or erosion protection provisions should be made to address the possibility of erosion to cut and fill slopes. During wet weather operations, the soil should be graded to drain and should be sealed by rubber tire rolling to minimize water infiltration.

Finish grading should include positive drainage away from all foundations. Section 1806.5.5 of the latest applicable edition of the California Building Code states that for graded soil sites, the top of any exterior foundation shall extend above the elevation of the street gutter at the point of discharge or the inlet of an approved drainage device a minimum of 12 inches plus 2 percent. We suggest that downspouts be tight piped via an area drain network and discharged to an appropriate non-erosive outlet.

All final grades should provide rapid removal of surface water runoff; ponding water should not be allowed on building pads or adjacent to foundations or other structural improvements.

5.7 Seismic Design Criteria

Based on the latest applicable edition of the California Building Code, Chapter 16, Division IV, and our site investigation findings, the following seismic parameters are recommended from a geotechnical perspective for structural design. The final choice of design parameters, however, remains the purview of the project structural engineer.



| CBC - CHAP. 16 TABLE NO. | SEISMIC PARAMETER | RECOMMENDED VALUE | |
|-----------------------------|------------------------------------|----------------------|-------|
| 16-I | Seismic Zone Factor Z | 0.30 | |
| 16-J | Soil Profile Type | S_B | S_C |
| 16-Q | Seismic Coefficient (C_a) | 0.30 | 0.33 |
| 16-R | Seismic Coefficient (C_v) | 0.30 | 0.45 |
| 16-S,-T | Near Source Factors (N_a, N_v) | 1.0 | |
| 16-U | Seismic Source Type | C | |



6.0 LIMITATIONS AND UNIFORMITY OF CONDITIONS

1. This report has been prepared for the exclusive use of SACRAMENTO COUNTRY DAY SCHOOL for specific application to the SACRAMENTO COUNTRY DAY SCHOOL project. Youngdahl Consulting Group, Inc. has endeavored to comply with generally accepted geotechnical engineering practice common to the local area. Youngdahl Consulting Group, Inc. makes no other warranty, express or implied.
2. As of the present date, the findings of this report are valid for the property studied. With the passage of time, changes in the conditions of a property can occur whether they be due to natural processes or to the works of man on this or adjacent properties. Legislation or the broadening of knowledge may result in changes in applicable standards. Changes outside of our control may cause this report to be invalid, wholly or partially. Therefore, this report should not be relied upon after a period of three years without our review nor should it be used or is it applicable for any properties other than those studied.
3. Section 3317.8 in Appendix Chapter 33 of the latest edition of the California Building Code is applicable to this report. This section states that, in regard to the transfer of responsibility, if the Geotechnical Engineer of Record for the project site is not maintained into and through the grading phase of the project, the work shall be stopped until the replacement has agreed in writing to accept their responsibility within the area of technical competence for approval upon completion of the work.

WARNING: Do not apply any of this report's conclusions or recommendations if the nature, design, or location of the facilities is changed. If changes are contemplated, Youngdahl Consulting Group, Inc. must review them to assess their impact on this report's applicability. Also note that Youngdahl Consulting Group, Inc. is not responsible for any claims, damages, or liability associated with any other party's interpretation of this report's subsurface data or reuse of this report's subsurface data or engineering analyses without the express written authorization of Youngdahl Consulting Group, Inc.

4. The analyses and recommendations contained in this report are based on limited windows into the subsurface conditions and data obtained from subsurface exploration. The methods used indicate subsurface conditions only at the specific locations where samples were obtained, only at the time they were obtained, and only to the depths penetrated. Samples cannot be relied on to accurately reflect the strata variations that usually exist between sampling locations. Should any variations or undesirable conditions be encountered during the development of the site, Youngdahl Consulting Group, Inc., will provide supplemental recommendations as dictated by the field conditions.
5. The recommendations included in this report have been based in part on assumptions about strata variations that may be tested only during earthwork. Accordingly, these recommendations should not be applied in the field unless Youngdahl Consulting Group, Inc. is retained to perform construction observation and thereby provide a complete professional geotechnical engineering service through the observational method. Youngdahl Consulting Group, Inc. cannot assume responsibility or liability for the adequacy



of its recommendations when they are used in the field without Youngdahl Consulting Group, Inc. being retained to observe construction. Unforeseen subsurface conditions containing soft native soils, loose or previously placed non-engineered fills should be a consideration while preparing for the grading of the property. It should be noted that it is the responsibility of the owner or his/her representative to notify Youngdahl Consulting Group, Inc., in writing, a minimum of 48 hours before any excavations commence at the site.

6. Our experience has shown that vapor transmission through concrete is controlled through proper concrete mix design. As such, proper control of moisture vapor transmission should be considered in the design of the slab as provided by the project architect, structural or civil engineer. It should be noted that placement of the recommended plastic membrane, proper mix design, and proper slab underlayment and detailing per ASTM E1643 and E1745 will not provide a waterproof condition. If a waterproof condition is desired, we recommend that a waterproofing expert be consulted for slab design.
7. Following site development, additional water sources (ie. landscape watering, downspouts) are generally present. The presence of low permeability materials can prohibit rapid dispersion of surface and subsurface water drainage. Utility trenches typically provide a conduit for water distribution. Provisions may be necessary to mitigate adverse effects of perched water conditions. Mitigation measures may include the construction of cut-off systems and/or plug and drain systems. Close coordination between the design professionals regarding drainage and subdrainage conditions may be warranted.

Seepage may be observed emanating from the cut slopes following their excavation during the following rainy season or following development of the areas above the cut. Generally this seepage is not enough flow to be a stability issue to the cut slope, but may be an issue for the owner of the lot at the base of the cut from a surface drainage and standing water (damp spot) standpoint. This amount of water is generally collected easily with landscaping drainage, surface drainage at the toe of the slope, or subsurface toe drains. Recommendations may be provided at the time of observed seepage, however, we recommend that the developer of the property disclose this possibility to future owners.

APPENDIX A

Field Study

Vicinity Map

Site Plan

Logs of Exploratory Test Pits



Introduction

The contents of this appendix shall be integrated with the geotechnical engineering study of which it is a part. They shall not be used in whole or in part as a sole source for information or recommendations regarding the subject site.

Field study

Our field study included a site reconnaissance by a *Youngdahl Consulting Group, Inc.*, representative followed by a subsurface exploration program conducted on 9 through 11 July 2003, which included the excavation of 37 test pits (20 geotechnical, 10 for septic design, 7 for geology/groundwater) under his direction at the approximate locations shown on Figure A-2, this Appendix. Excavation of the test pits was accomplished with a John Deere 310SG rubber tire-mounted backhoe equipped with 18 and 24 inch wide buckets. Bulk samples were collected from the pits.

The Exploratory Test Pit Logs describe the vertical sequence of soils and materials encountered in each test pit, based primarily on our field classifications and supported by our subsequent laboratory examination and testing. Where a soil contact was observed to be gradual, our logs indicate the average contact depth. Our logs also graphically indicate the sample type, sample number and approximate depth of each soil sample obtained from the test pits.

The soils encountered were logged during excavation and provide the basis for the "Logs of Exploratory Test Pits", Figures A-3 through A-37, this Appendix. These logs show a graphic representation of the soil profile and the location and depths at which samples were collected.

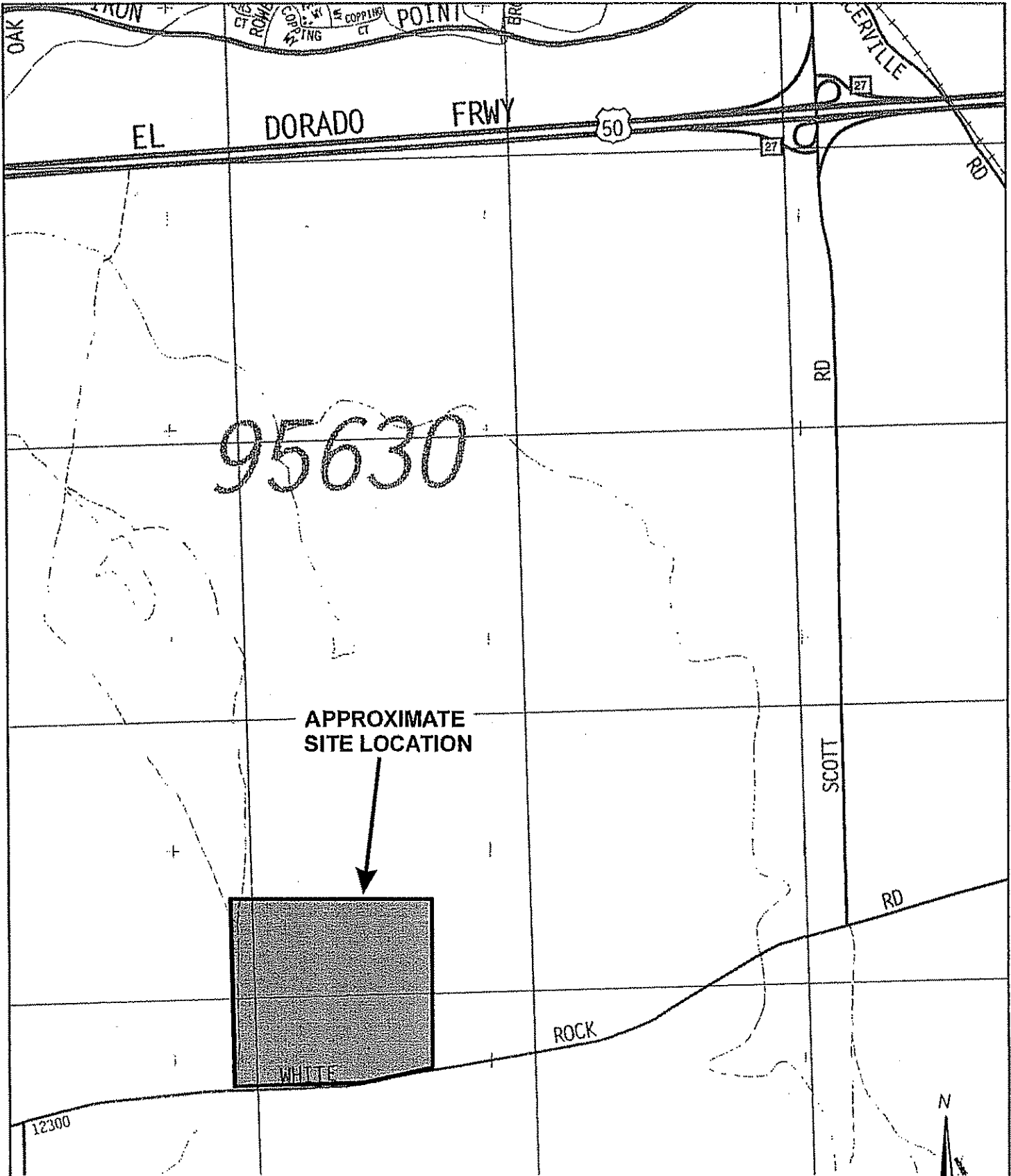

BASE MAP REFERENCE: Sacramento and Solano Counties Thomas Guide 2000 Edition, Page 281

APPENDIX C

Bulk Asbestos Material Analysis



Bulk Asbestos Material Analysis

(Air Resources Board Proposed Method 435)

Youngdahl & Associates, Inc.
David Sederquist
1234 Glenhaven Court
El Dorado Hills, CA 95630

Client ID: 3691
Report Number: B052856
Date Received: 07/23/03
Date Analyzed: 07/25/03
Date Reported: 07/25/03

Sample Number: **ASB-1**
Sample Layer Description: Brown Soil
Job ID / Site: 03289 - Sacramento County Day School, Folsom

Lab Number: 10252577
FASI Job ID: 3691-36

Sample Preparation and Analysis

Samples were analyzed by the Air Resources Board's Proposed Method 435, Determination of Asbestos Content of Serpentine Aggregate. Samples were ground to 200 particle size in the laboratory. Approximately 1 pint was retained for analysis. Samples were prepared for observation according to the guidelines of Exception I and Exception II as defined by the 435 Method. Samples which contained less than 10% asbestos were prepared for observation according to the point count technique as defined by the 435 Method. This analysis was performed with a standard cross-hair reticle.

Layer Percentage of entire sample: 100

Visual Estimation Percentage: None Detected

Asbestos Type(s) Detected: None Detected

This result meets the requirements of Exception I as defined by the 435 Method.

James Flores, Laboratory Supervisor, Hayward Laboratory

Note: Limit of Quantification (LOQ) = 0.25%. Trace denotes the presence of asbestos below the LOQ. ND = None Detected.

Analytical results and reports are generated by Forensic Analytical at the request of and for the exclusive use of the person or entity (client) named on such report. Results, reports or copies of same will not be released by Forensic Analytical to any third party without prior written request from client. This report applies only to the sample(s) tested. Supporting laboratory documentation is available upon request. This report must not be reproduced except in full, unless approved by Forensic Analytical. The client is solely responsible for the use and interpretation of test results and reports requested from Forensic Analytical. This report must not be used by the client to claim product endorsement by NVLAP or any other agency of the U.S. Government. Forensic Analytical is not able to assess the degree of hazard resulting from materials analyzed. Forensic Analytical reserves the right to dispose of all samples after a period of thirty (30) days, according to all state and federal guidelines, unless otherwise specified. All samples were received in acceptable condition unless otherwise noted.



Bulk Asbestos Material Analysis

(Air Resources Board Proposed Method 435)

Youngdahl & Associates, Inc.
David Sederquist
1234 Glenhaven Court

El Dorado Hills, CA 95630

Client ID: 3691
Report Number: B052856
Date Received: 07/23/03
Date Analyzed: 07/25/03
Date Reported: 07/25/03

Sample Number: ASB-2
Sample Layer Description: Brown Soil
Job ID / Site: 03289 - Sacramento County Day School, Folsom

Lab Number: 10252578

FA SI Job ID: 3691-36

Sample Preparation and Analysis

Samples were analyzed by the Air Resources Board's Proposed Method 435, Determination of Asbestos Content of Serpentine Aggregate. Samples were ground to 200 particle size in the laboratory. Approximately 1 pint was retained for analysis. Samples were prepared for observation according to the guidelines of Exception I and Exception II as defined by the 435 Method. Samples which contained less than 10% asbestos were prepared for observation according to the point count technique as defined by the 435 Method. This analysis was performed with a standard cross-hair reticle.

Layer Percentage of entire sample: 100

Visual Estimation Percentage: None Detected

Asbestos Type(s) Detected: None Detected

This result meets the requirements of Exception I as defined by the 435 Method.

James Flores, Laboratory Supervisor, Hayward Laboratory

Note: Limit of Quantification (LOQ) = 0.25%. Trace denotes the presence of asbestos below the LOQ. ND = None Detected.

Analytical results and reports are generated by Forensic Analytical at the request of and for the exclusive use of the person or entity (client) named on such report. Results, reports or copies of same will not be released by Forensic Analytical to any third party without prior written request from client. This report applies only to the sample(s) tested. Supporting laboratory documentation is available upon request. This report must not be reproduced except in full, unless approved by Forensic Analytical. The client is solely responsible for the use and interpretation of test results and reports requested from Forensic Analytical. This report must not be used by the client to claim product endorsement by NVLAP or any other agency of the U.S. Government. Forensic Analytical is not able to assess the degree of hazard resulting from materials analyzed. Forensic Analytical reserves the right to dispose of all samples after a period of thirty (30) days, according to all state and federal guidelines, unless otherwise specified. All samples were received in acceptable condition unless otherwise noted.



Bulk Asbestos Material Analysis

(Air Resources Board Proposed Method 435)

Youngdahl & Associates, Inc.
David Sederquist
1234 Glenhaven Court
El Dorado Hills, CA 95630

Client ID: 3691
Report Number: B052856
Date Received: 07/23/03
Date Analyzed: 07/25/03
Date Reported: 07/25/03

Sample Number: **ASB-3**
Sample Layer Description: Brown Soil
Job ID / Site: 03289 - Sacramento County Day School, Folsom

Lab Number: 10252579
FASI Job ID: 3691-36

Sample Preparation and Analysis

Samples were analyzed by the Air Resources Board's Proposed Method 435, Determination of Asbestos Content of Serpentine Aggregate. Samples were ground to 200 particle size in the laboratory. Approximately 1 pint was retained for analysis. Samples were prepared for observation according to the guidelines of Exception I and Exception II as defined by the 435 Method. Samples which contained less than 10% asbestos were prepared for observation according to the point count technique as defined by the 435 Method. This analysis was performed with a standard cross-hair reticle.

Layer Percentage of entire sample: 100
Visual Estimation Percentage: None Detected
Asbestos Type(s) Detected: None Detected

This result meets the requirements of Exception I as defined by the 435 Method.

James Flores, Laboratory Supervisor, Hayward Laboratory

Note: Limit of Quantification (LOQ) = 0.25%. Trace denotes the presence of asbestos below the LOQ. ND = None Detected.

Analytical results and reports are generated by Forensic Analytical at the request of and for the exclusive use of the person or entity (client) named on such report. Results, reports or copies of same will not be released by Forensic Analytical to any third party without prior written request from client. This report applies only to the sample(s) tested. Supporting laboratory documentation is available upon request. This report must not be reproduced except in full, unless approved by Forensic Analytical. The client is solely responsible for the use and interpretation of test results and reports requested from Forensic Analytical. This report must not be used by the client to claim product endorsement by NVLAP or any other agency of the U.S. Government. Forensic Analytical is not able to assess the degree of hazard resulting from materials analyzed. Forensic Analytical reserves the right to dispose of all samples after a period of thirty (30) days, according to all state and federal guidelines, unless otherwise specified. All samples were received in acceptable condition unless otherwise noted.



Bulk Asbestos Material Analysis

(Air Resources Board Proposed Method 435)

Youngdahl & Associates, Inc.
David Sederquist
1234 Glenhaven Court
El Dorado Hills, CA 95630

Client ID: 3691
Report Number: B052856
Date Received: 07/23/03
Date Analyzed: 07/25/03
Date Reported: 07/25/03

Sample Number: ASB-4
Sample Layer Description: Grey Soil
Job ID / Site: 03289 - Sacramento County Day School, Folsom

Lab Number: 10252580
FASI Job ID: 3691-36

Sample Preparation and Analysis

Samples were analyzed by the Air Resources Board's Proposed Method 435, Determination of Asbestos Content of Serpentine Aggregate. Samples were ground to 200 particle size in the laboratory. Approximately 1 pint was retained for analysis. Samples were prepared for observation according to the guidelines of Exception I and Exception II as defined by the 435 Method. Samples which contained less than 10% asbestos were prepared for observation according to the point count technique as defined by the 435 Method. This analysis was performed with a standard cross-hair reticle.

Layer Percentage of entire sample: 100
Visual Estimation Percentage: None Detected
Asbestos Type(s) Detected: None Detected

This result meets the requirements of Exception I as defined by the 435 Method.

James Flores, Laboratory Supervisor, Hayward Laboratory

Note: Limit of Quantification (LOQ) = 0.25%. Trace denotes the presence of asbestos below the LOQ. ND = None Detected.

Analytical results and reports are generated by Forensic Analytical at the request of and for the exclusive use of the person or entity (client) named on such report. Results, reports or copies of same will not be released by Forensic Analytical to any third party without prior written request from client. This report applies only to the sample(s) tested. Supporting laboratory documentation is available upon request. This report must not be reproduced except in full, unless approved by Forensic Analytical. The client is solely responsible for the use and interpretation of test results and reports requested from Forensic Analytical. This report must not be used by the client to claim product endorsement by NVLAP or any other agency of the U.S. Government. Forensic Analytical is not able to assess the degree of hazard resulting from materials analyzed. Forensic Analytical reserves the right to dispose of all samples after a period of thirty (30) days, according to all state and federal guidelines, unless otherwise specified. All samples were received in acceptable condition unless otherwise noted.



Bulk Asbestos Material Analysis

(Air Resources Board Proposed Method 435)

oungdahl & Associates, Inc.
David Sederquist
1234 Glenhaven Court
il Dorado Hills, CA 95630

Client ID: 3691
Report Number: B052856
Date Received: 07/23/03
Date Analyzed: 07/25/03
Date Reported: 07/25/03

Sample Number: ASB-5

Lab Number: 10252581

Sample Layer Description: Grey Soil

Job ID / Site: 03289 - Sacramento County Day School, Folsom

FASI Job ID: 3691-36

Sample Preparation and Analysis

Samples were analyzed by the Air Resources Board's Proposed Method 435, Determination of Asbestos Content of Serpentine Aggregate. Samples were ground to 200 particle size in the laboratory. Approximately 1 pint was retained for analysis. Samples were prepared for observation according to the guidelines of Exception I and Exception II as defined by the 435 Method. Samples which contained less than 10% asbestos were prepared for observation according to the point count technique as defined by the 435 Method. This analysis was performed with a standard cross-hair reticle.

Layer Percentage of entire sample: 100

Visual Estimation Percentage: None Detected

Asbestos Type(s) Detected: None Detected

This result meets the requirements of Exception I as defined by the 435 Method.

James Flores, Laboratory Supervisor, Hayward Laboratory

Note: Limit of Quantification (LOQ) = 0.25%. Trace denotes the presence of asbestos below the LOQ. ND = None Detected.

Analytical results and reports are generated by Forensic Analytical at the request of and for the exclusive use of the person or entity (client) named on such report. Results, reports or copies of same will not be released by Forensic Analytical to any third party without prior written request from client. This report applies only to the sample(s) listed. Supporting laboratory documentation is available upon request. This report must not be reproduced except in full, unless approved by Forensic Analytical. The client is solely responsible for the use and interpretation of test results and reports requested from Forensic Analytical. This report must not be used by the client to claim product endorsement by NVLAP or any other agency of the U.S. Government. Forensic Analytical is not able to assess the degree of hazard resulting from materials analyzed. Forensic Analytical reserves the right to dispose of all samples after a period of thirty (30) days, according to all state and federal guidelines, unless otherwise specified. All samples are received in acceptable condition unless otherwise noted.



Bulk Asbestos Material Analysis

(Air Resources Board Proposed Method 435)

Youngdahl & Associates, Inc.
David Sederquist
1234 Glenhaven Court
31 Dorado Hills, CA 95630

Client ID: 3691
Report Number: B052856
Date Received: 07/23/03
Date Analyzed: 07/25/03
Date Reported: 07/25/03

Sample Number: ASB-6
Sample Layer Description: Grey Soil
Job ID / Site: 03289 - Sacramento County Day School, Folsom

Lab Number: 10252582
FA SI Job ID: 3691-36

Sample Preparation and Analysis

Samples were analyzed by the Air Resources Board's Proposed Method 435, Determination of Asbestos Content of Serpentine Aggregate. Samples were ground to 200 particle size in the laboratory. Approximately 1 pint was retained for analysis. Samples were prepared for observation according to the guidelines of Exception I and Exception II as defined by the 435 Method. Samples which contained less than 10% asbestos were prepared for observation according to the point count technique as defined by the 435 Method. This analysis was performed with a standard cross-hair reticle.

Layer Percentage of entire sample: 100

Visual Estimation Percentage: None Detected

Asbestos Type(s) Detected: None Detected

This result meets the requirements of Exception I as defined by the 435 Method.

James Flores, Laboratory Supervisor, Hayward Laboratory

Note: Limit of Quantification (LOQ) = 0.25%. Trace denotes the presence of asbestos below the LOQ. ND = None Detected.

Analytical results and reports are generated by Forensic Analytical at the request of and for the exclusive use of the person or entity (client) named on such report. Results, reports or copies of same will not be released by Forensic Analytical to any third party without prior written request from client. This report applies only to the sample(s) tested. Supporting laboratory documentation is available upon request. This report must not be reproduced except in full, unless approved by Forensic Analytical. The client is solely responsible for the use and interpretation of test results and reports requested from Forensic Analytical. This report must not be used by the client to claim product endorsement by NVLAP or any other agency of the U.S. Government. Forensic Analytical is not able to assess the degree of hazard resulting from materials analyzed. Forensic Analytical reserves the right to dispose of all samples after a period of thirty (30) days, according to all state and federal guidelines, unless otherwise specified. All samples were received in acceptable condition unless otherwise noted.

3691-36



1234 Glenhaven Court
El Dorado Hills, CA 95762

Telephone: (916) 933-0633 Fax: (916) 933-6482

Lab Number: _____
Report Due Date: _____

CHAIN OF CUSTODY

Client: Youngdahl Consulting Group, Inc.
 Address: 1234 Glenhaven Court
 City, State & Zip: El Dorado Hills, CA 95762 Project Name: Sacramento Country Day School
 Contact: David Sederquist Project Number: 03289
 Telephone: (916) 933-0633 Collection Point: Test Pits
 Fax Number: (916) 933-6482 Collector's Name: David Sederquist
 Fax Results: Y N Page 1 of 1 Location (City): Folsom

| SAMPLE TYPE CODES | | S A M P L E T Y P E | C O N T A I N E R S | ANALYSES REQUESTED | | | | | | | | | | | | | | | | | | |
|--|---------------------------------------|--|--|---------------------------------|--|--|--|--|--|--|--|--|--|--|--|--|--|--|--|--|--|--|
| *Matrix | *Container Type | | | / / / / / / / / / / / / / / / / | | | | | | | | | | | | | | | | | | |
| Soil = S Asphalt = A Bag = B | P = Plastic G = Glass O = Other | | | ARBIM 435 | | | | | | | | | | | | | | | | | | |
| TURNAROUND TIME REQUESTED | | | | | | | | | | | | | | | | | | | | | | |
| Standard <input checked="" type="checkbox"/> | Lab Manager Approval | | | | | | | | | | | | | | | | | | | | | |
| RUSH | | | | | | | | | | | | | | | | | | | | | | |
| Special | | | | | | | | | | | | | | | | | | | | | | |
| CLIENT'S SAMPLE ID/LOCATION | Date | Time | | | | | | | | | | | | | | | | | | | | |

| | | | | | | | | | | | | | | | | | | | | | | | |
|-------|-------|------|------|---|---|---|--|--|--|--|--|--|--|--|--|--|--|--|--|--|--|--|--|
| ASB-1 | TP-12 | 7/22 | 0825 | S | B | X | | | | | | | | | | | | | | | | | |
| ASB-2 | TP-13 | 7/22 | 0835 | S | B | X | | | | | | | | | | | | | | | | | |
| ASB-3 | TP-14 | 7/22 | 0850 | S | B | X | | | | | | | | | | | | | | | | | |
| ASB-4 | TP-15 | 7/22 | 0902 | S | B | X | | | | | | | | | | | | | | | | | |
| ASB-5 | TP-18 | 7/22 | 0908 | S | B | X | | | | | | | | | | | | | | | | | |
| ASB-6 | TP-20 | 7/22 | 0916 | S | B | X | | | | | | | | | | | | | | | | | |

Instructions/Comments/Special Requirements:

| SAMPLE RECEIPT | | | Date | Time | Samples Relinquished By | Samples Received By |
|-------------------|---|---|------|------|-------------------------|-------------------------|
| Received Cold | Y | N | 7/22 | 1600 | David C. Sederquist | E. Rumbolt 7/22/02 1046 |
| Custody Seals | Y | N | | | | |
| Seals Intact | Y | N | | | | |
| No. of Containers | | | | | | |

EXPANSION INDEX TEST (ASTM 4829, UBC 18-25)

SAMPLE NO.: BULK 4

DEPTH:

SAMPLE DESCRIPTION: Red Brown Clayey SAND w/trace gravel

| EXPANSION INDEX | EXPANSION POTENTIAL |
|-----------------|---------------------|
| 0 - 20 | Very Low |
| 21 - 50 | Low |
| 51 - 90 | Moderate |
| 91 - 130 | High |
| Over 130 | Very High |

| | |
|--------------------------|------------|
| Tested Expansion Index : | 22 |
| Expansion Potential : | LOW |

APPENDIX F2

Preliminary Geotechnical Engineering Report –
Folsom 138 Property

**PRELIMINARY
GEOTECHNICAL
ENGINEERING REPORT**

14

FOLSOM 138 PROPERTY

Folsom White Rock LLC

**WKA No.
6187.01**

**August 31,
2004**



WALLACE • KUHL & ASSOCIATES INC.



**WALLACE • KUHL
& ASSOCIATES INC.**

Geotechnical Engineering

Engineering Geology

Environmental Consulting

Remediation Services

Construction Inspection

Materials Testing

Preliminary Geotechnical Engineering Report

FOLSOM 138 PROPERTY

Placerville and White Rock Roads

Sacramento County, California

WKA No. 6187.01

August 31, 2004

INTRODUCTION

General

We have completed a preliminary geotechnical engineering evaluation of the Folsom 138 Property located in Sacramento County, California. Our work has been performed in accordance with authorization on August 5, 2004 from Woodside Homes, and the scope of work outlined in our proposal letter dated August 4, 2004.

Scope

Our scope of work included the following tasks:

1. site reconnaissance;
2. review of historic USGS topographic maps and aerial photographs of the property;
3. subsurface investigation, including the excavation and sampling of 12 test pits to a maximum depth of approximately 9½ feet below the ground surface;
4. laboratory testing of selected soil samples;
5. engineering analyses; and,
6. preparation of this report.

CORPORATE OFFICE
3050 Industrial Boulevard
West Sacramento
CA 95691
Tel 916.372.1434
Fax 916.372.2565

ROCKLIN OFFICE
500 Menlo Drive
Suite 100
Rocklin, CA 95765
Tel 916.435.9722
Fax 916.435.9822

STOCKTON OFFICE
3410 West Hammer Lane
Suite F
Stockton, CA 95219
Tel 209.234.7722
Fax 209.234.7727

Plates and Attachments

Our report contains a Site Vicinity Map (Plate No. 1); a Site Plan showing test pit locations (Plate No. 2); and, Logs of Test Pits (Plates No. 3 and 4). An explanation of the classification system used on the logs is included on Plate No. 5. Appendix A contains general information regarding project concepts, exploratory methods used during our field investigation, and laboratory test results.

Project Description

We understand the site likely will be developed with single-family residential subdivisions. We assume typical construction will consist of one- and two-story structures, with interior slab-on-grade floors. Associated development will include underground utilities and interior roadways.

FINDINGS

Site Conditions

The Folsom 138 Property is located at on the north side of White Rock Road and along the northeast side of Placerville Road, south of Highway 50 in Sacramento County, California (see Plate No. 1). The site is bounded to the west, north and east by undeveloped rangeland and to the south by White Rock Road, beyond which is pastureland. Topography of the property is undulating to moderately and steeply rolling terrain with surface elevations ranging between approximately +490 feet to +660 feet relative to mean sea level (msl), based on review of a USGS *Topographic Map of the Clarksville Quadrangle, California* (photorevised 1980).

At the time of our site reconnaissance the site was undeveloped and used to graze cattle. Cattle fencing enclose the site. The north and east boundaries have one to two foot high rock walls inside and parallel to the cattle fence. A low area with standing water was observed near the midpoint of the southern boundary. A large outcrop of quartz rock was observed in the south central portion of the site; the outcrop is approximately three feet high and 50 feet long by 20 feet wide. Several mature trees were observed near the southeast portion of the site near White Rock Road.



Review of available aerial photographs taken in 1962, 1971, 1981, 1989 and 2001 indicates the property has been undeveloped and used as grazing land during at least this period of time.

Site Geology

The property is predominately underlain by metavolcanic and pyroclastic rock formations as identified by the California Department of Conservation: Mines and Geology publication, "Generalized Geologic Map of the Folsom 15-Minute Quadrangle." Based on the map, the Copper Hill Volcanic formation appears to cover the majority of the property, consisting of mostly mafic to andesitic pyroclastic rocks, lava, and pillow lava, with subordinate felsic porphyritic and pyroclastic rocks. A very small portion of the site near White Rock Road is indicated to be underlain by Quaternary alluvium.

The *Generalized Geology Map of the Folsom 15-Minute Quadrangle* indicates the west branch of the Bear Mountains Fault is located approximately 1.7 miles east of the Folsom 138 Property, and represents the westernmost fault within the "Foothills Fault Zone." The site is not identified within a *Alquist-Priolo Fault Study Zone*, meaning that the State has not identified this portion of the Foothills Fault Zone as being active within the last 11,000 years. The Bear Mountains Fault is mapped as a pre-Quaternary fault (not active within the last 1.6 million years), except for the "Rescue Lineament," which may have been active in late Quaternary time. The Rescue Lineament is located about 9 miles northeast of the site.

According to the General Plan for El Dorado County:

"No active faults have been identified in El Dorado County. One fault, part of the Rescue Lineament-Bear Mountains fault zone, is classified as a well-located late-Quaternary fault (DOC 2000); therefore, it represents the only potentially active fault in the county. It is part of the Foothill Fault Suture zone system, which was considered inactive until a Richter scale magnitude 5.7 earthquake occurred near Oroville on August 1, 1975 (DOC 1990). All other faults located in El Dorado County are classified as pre-Quaternary (inactive)."



Subsurface Conditions

Our site reconnaissance, test pits and bulk sampling indicate a subsurface profile of very fine sandy silts with variable rock fragments, underlain by weathered to unweathered metavolcanic rocks. In some test pits a thin layer of silty, very fine sandy clay was observed at the surface of the weathered portions of the metavolcanic rock. Test Pits No. 11 and 12 encountered very thinly bedded metasedimentary rock below five to eight feet. Review of the 1993 U.S. Department of Agriculture, Soil Conservation Service (SCS) *Soil Survey of Sacramento County, California* indicates that the near-surface soils on the subject property consist of two different soil types including the "Argonaut-Auburn complex, 3 to 8 percent slopes", which is located in a very small portion of the site near White Rock Road, and the rest of the site consists of "Argonaut-Auburn-Rock outcrop complex, 8 to 30 percent slopes."

- The Argonaut complex typically consists of a surface layer of reddish yellow and light yellowish brown loam about eight inches thick. The upper six inches of the subsoil is yellowish red gravelly loam. The lower 15 inches is a claypan of variegated strong brown, yellowish brown, and yellowish red clay and clay loam. Highly weathered schist is at a depth of about 29 inches. The Auburn complex typically consists of a surface layer and subsoil of strong brown, reddish yellow, and yellowish red loam. Fractured metabasic bedrock is at a depth of about 14 inches.

The SCS soil descriptions are generally consistent with our site observations and previous experience in the area.

Ground Water

Free ground water was not encountered in the test pits excavated on August 12, 2004. Based on our experience in the vicinity of the project, we do not anticipate that the permanent ground water table is within 100 feet of the existing ground surfaces.

Subsurface Conditions

Our site reconnaissance, test pits and bulk sampling indicate a subsurface profile of very fine sandy silts with variable rock fragments, underlain by weathered to unweathered metavolcanic rocks. In some test pits a thin layer of silty, very fine sandy clay was observed at the surface of the weathered portions of the metavolcanic rock. Test Pits No. 11 and 12 encountered very thinly bedded metasedimentary rock below five to eight feet. Review of the 1993 U.S. Department of Agriculture, Soil Conservation Service (SCS) *Soil Survey of Sacramento County, California* indicates that the near-surface soils on the subject property consist of two different soil types including the "Argonaut-Auburn complex, 3 to 8 percent slopes", which is located in a very small portion of the site near White Rock Road, and the rest of the site consists of "Argonaut-Auburn-Rock outcrop complex, 8 to 30 percent slopes."

- The Argonaut complex typically consists of a surface layer of reddish yellow and light yellowish brown loam about eight inches thick. The upper six inches of the subsoil is yellowish red gravelly loam. The lower 15 inches is a claypan of variegated strong brown, yellowish brown, and yellowish red clay and clay loam. Highly weathered schist is at a depth of about 29 inches. The Auburn complex typically consists of a surface layer and subsoil of strong brown, reddish yellow, and yellowish red loam. Fractured metabasic bedrock is at a depth of about 14 inches.

The SCS soil descriptions are generally consistent with our site observations and previous experience in the area.

Ground Water

Free ground water was not encountered in the test pits excavated on August 12, 2004. Based on our experience in the vicinity of the project, we do not anticipate that the permanent ground water table is within 100 feet of the existing ground surfaces.



CONCLUSIONS

General

Our field and laboratory investigations indicate the Folsom 138 property is suitable for the proposed single-family residential development concept from the standpoint of soils and geologic considerations. Earth materials are considered to have no unusual or adverse engineering characteristics, which would preclude any of the elements of the proposed development.

Seismic Considerations

No active or potentially active faults are known to underlie the Folsom 138 Property, based on the published geologic maps or aerial photographs that we reviewed. The site is not located within an Alquist-Priolo Fault Study Zone, and we observed no surface evidence of faulting during our site reconnaissance. Therefore, it is our opinion that ground rupture at the site resulting from seismic activity is unlikely.

According to the 2001 edition of the California Building Code (Title 24 of the California Code of Regulations, Chapter 16; California amendments to the 1997 edition of the Uniform Building Code) the site is located within Seismic Zone 3. A soil profile type S_C , as referenced in Table 16A-J of Chapter 16 of the 2001 CBC is considered appropriate for this site. The project site is not located within 15 km of a Type A or Type B fault source, as defined by CBC Table 16A-U.

Asbestos Potential

The test pits completed during our geotechnical investigation revealed no indication that ultramafic rocks (i.e., serpentine) commonly associated with the naturally occurring asbestos minerals, to be present at the site. However, our experience in this region as well as our review of recent publications suggests that the site may be located in an area where the geologic environment intermittently contains minerals identified as naturally occurring asbestos.

If these mineral assemblages are identified before or during grading operations on the site, Sacramento County will likely require the preparation and approval of a Naturally Occurring Asbestos, Dust Mitigation Plan (NOA, DMP). This plan may require special handling of the asbestos material and may result in project delays or increased costs.



Building Support

In our opinion, the native soils and rock are capable of supporting the proposed residential structures if the near-surface soils are properly compacted and engineered fill is properly placed and compacted during earthwork. Removal of saturated and organic-laden soils from drainages and the proper backfilling of these features will be important to providing uniform support for the planned structures in those areas.

Excavation Conditions

The subject site is underlain by near-surface rocky soils and metavolcanic rock. The uppermost alluvial soils should be excavatable with conventional excavation equipment typically used in the area. The metamorphic rock will be more difficult to excavate, and likely will require large excavations or possibly blasting to achieve deep excavations. The upper five feet of soil and weathered rock should be relatively stable when excavated with near-vertical sidewalls, unless the materials are saturated. Excavations deeper than five feet should be sloped or braced in conformance with current Cal/OSHA regulations.

Material Suitability

The native soils and weathered rock will be suitable for use as engineered fill, provided they do not contain significant concentrations of vegetation or debris, and they are at an appropriate moisture content to allow proper compaction. Deeper excavations may result in larger rocks that will not be suitable unless broken down into smaller fragments (say 12 inches or less) that can be properly compacted.

Soil Expansion Potential

Laboratory testing of the surface soils above the unweathered metavolcanic rock indicates these soils possess low to medium expansion potential when tested in accordance with the ASTM D4829 (UBC 29-2) test method (see Plates No. A1 and A2). However, previous experience and laboratory testing on nearby projects has revealed the clay soils directly above the weathered rock to be highly expansive. Use of expansive clays, if present, should be avoided within building



pads and areas exposing clay at subgrade level should be excavated and the clays replaced with low expansion materials.

Ground Water and Seepage

Review of available ground water information from within the vicinity of the site, suggests that the static ground water table should not adversely affect construction of the proposed residential improvements. However, experience in the nearby El Dorado Hills area suggests that seepage may be encountered during development of the property, requiring the construction of subdrainage. Typical subdrains consist of perforated pipe and gravel, surrounded by non-woven geotextile fabric. Design of subdrains should be performed during construction when actual seepage conditions are exposed.

Seasonal Water

The near-surface soils would be in a near-saturated condition during and for a considerable period following the rainy season. Grading operations attempted following the onset of winter rains and prior to prolonged drying periods will be hampered by high soil moisture contents. Such soils, intended for use as engineered fill, will require considerable aeration to reach a moisture content that will permit the recommended compaction to be achieved.

Preliminary Soil Corrosion Potential

Three composite samples of near-surface soils were submitted to Sunland Analytical Lab, Inc. for testing to determine pH, resistivity, sulfate and chloride concentrations to help evaluate the potential for corrosive attack upon buried structures. The test results for the samples revealed minimum resistivities of 2550 to 3480 ohm-centimeters (Ω -cm) and a soil pH ranging from 5.54 to 6.33. Sulfates were recorded at 0.6 to 1.7 parts per million (ppm) and chlorides at 5.6 to 8.0 ppm. Results of the testing performed by Sunland Analytical Lab are summarized on Plates No. A6 through A8.



Caltrans¹ considers a site to be corrosive to structural elements if one or more of the following conditions exist for the representative soil sample(s) taken at the site:

Chloride concentration is greater than or equal to 500 ppm, sulfate concentration is greater than or equal to 2000 ppm, or the pH is 5.5 or less.

Caltrans defines areas as either corrosive or non-corrosive based on the above information. Comparing this information to the test results indicates the native soils are non-corrosive to structural elements. Table 19-A-4 of the 1997 UBC, Requirements for Concrete Exposed to Sulfate-Containing Solutions, indicates the sulfate exposure for the samples tested are Negligible. Based on this table ordinary Type I-II Portland cement is indicated to be suitable for use on the project, assuming a minimum cover is maintained over the reinforcement.

Wallace-Kuhl & Associates are not corrosion engineers. Therefore, to further define the soil corrosion potential at the site, or to determine the need or design parameters for cathodic protection or grounding systems a corrosion engineer should be consulted.

PRELIMINARY RECOMMENDATIONS

Foundation Design and Floor Slab Support

The proposed residential structures could be supported upon continuous and/or isolated spread foundations extending at least 12 inches below lowest adjacent soil grade. Foundations should be continuous around the perimeter of the buildings to help minimize moisture variations beneath the structures. Foundations may be sized for maximum allowable soil pressures of approximately 2000 psf for dead load plus live load with a 1/3 increase for consideration of seismic or wind forces.

Interior slab-on-grade concrete floors would be suitable for this site, provided slabs are properly designed and constructed with regard to moisture vapor penetration resistance and the slabs are

¹ California Department of Transportation, Division of Engineering Services, Materials Engineering and Testing Services, Corrosion Technology Branch, *Corrosion Guideline*, Version 1.0, September 2003.



adequately reinforced. Typical slab reinforcement would consist of flat sheets of welded-wire fabric or No. 3 rebar at 24-inch center-to-center spacing.

Pavement Subgrade Quality

Due to the rolling site terrain, we anticipate that subgrade conditions will vary considerably. Laboratory testing on three samples of soil from the project site indicate Resistance ("R") values of 5 to 24. For soil subgrades which may contain clay we suggest a preliminary design R-value of 10. Experience also suggests that subgrades consisting of weathered rock materials will possess an R-value of around 40. Using these design values and the design traffic indices contained in the "Design Practice Guide" prepared by the Sacramento County Transportation Division, dated June 1, 1999, we have calculated the following pavement section alternatives. The procedures used for designing the pavement section are in general conformance with the "Flexible Pavement Structural Design Guide for California Cities and Counties" and applicable portions of the Caltrans Highway Design Manual.

Pavement Design Alternates
Subgrade R-value = 40

| Street Right-of-Way | Traffic Index (TI) | Type B Asphalt Concrete (inches) | Class 2 Aggregate Base (inches) |
|--|--------------------|----------------------------------|---------------------------------|
| 40' and 50' Residential | 5.0 | 2½ | 5 |
| 56' to 74' without Bus Routes | 6.0 | 2½ 3½* | 8 6 |
| 56' to 74' with Bus Routes and Cul-de-Sacs | 6.5 | 3 4* | 9 7 |
| 84' Streets | 9.0 | 4 5½* | 12 10 |
| 108' and 130' Streets | 10.0 | 5 6* | 14 12 |

* includes Caltrans safety factor



Pavement Design Alternates
Subgrade R-value = 10

| Street Right-of-Way | Traffic Index (TI) | Type B Asphalt Concrete (inches) | Class 2 Aggregate Base (inches) |
|--|--------------------|----------------------------------|---------------------------------|
| 40' and 50' Residential | 5.0 | 2½ | 10 |
| 56' to 74' without Bus Routes | 6.0 | 2½ | 14 |
| | | 3½* | 12 |
| 56' to 74' with Bus Routes and Cul-de-Sacs | 6.5 | 3 | 16 |
| | | 4* | 13 |
| 84' Streets | 9.0 | 4 | 22 |
| | | 5½* | 19 |
| 108' and 130' Streets | 10.0 | 5 | 24 |
| | | 6* | 22 |

*includes Caltrans safety factor

Future Studies

This report is intended to provide an overview of the suitability of the site for residential development. Prior to further development a detailed subsurface investigation of the site, including additional borings and/or test pits and possibly seismic traverses, should be performed along with a more extensive laboratory testing program and a geotechnical report prepared presenting specific recommendations for design and construction of the project.

LIMITATIONS

The proceeding sections of this report should be considered a general overview of the geotechnical engineering aspects of site development. They are not intended for specific design or construction of any of the project improvements. At an appropriate time prior to development, our firm should be retained to conduct a comprehensive, site specific geotechnical engineering investigation for this project.



We appreciate this opportunity to be of service. Please contact our office if you have any questions regarding our report or the geotechnical aspects of site development.

Wallace-Kuhl & Associates, Inc.

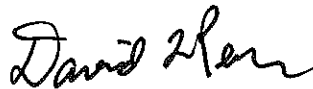

David L. Perry
Staff Geologist



Stephen L. French
Senior Engineer



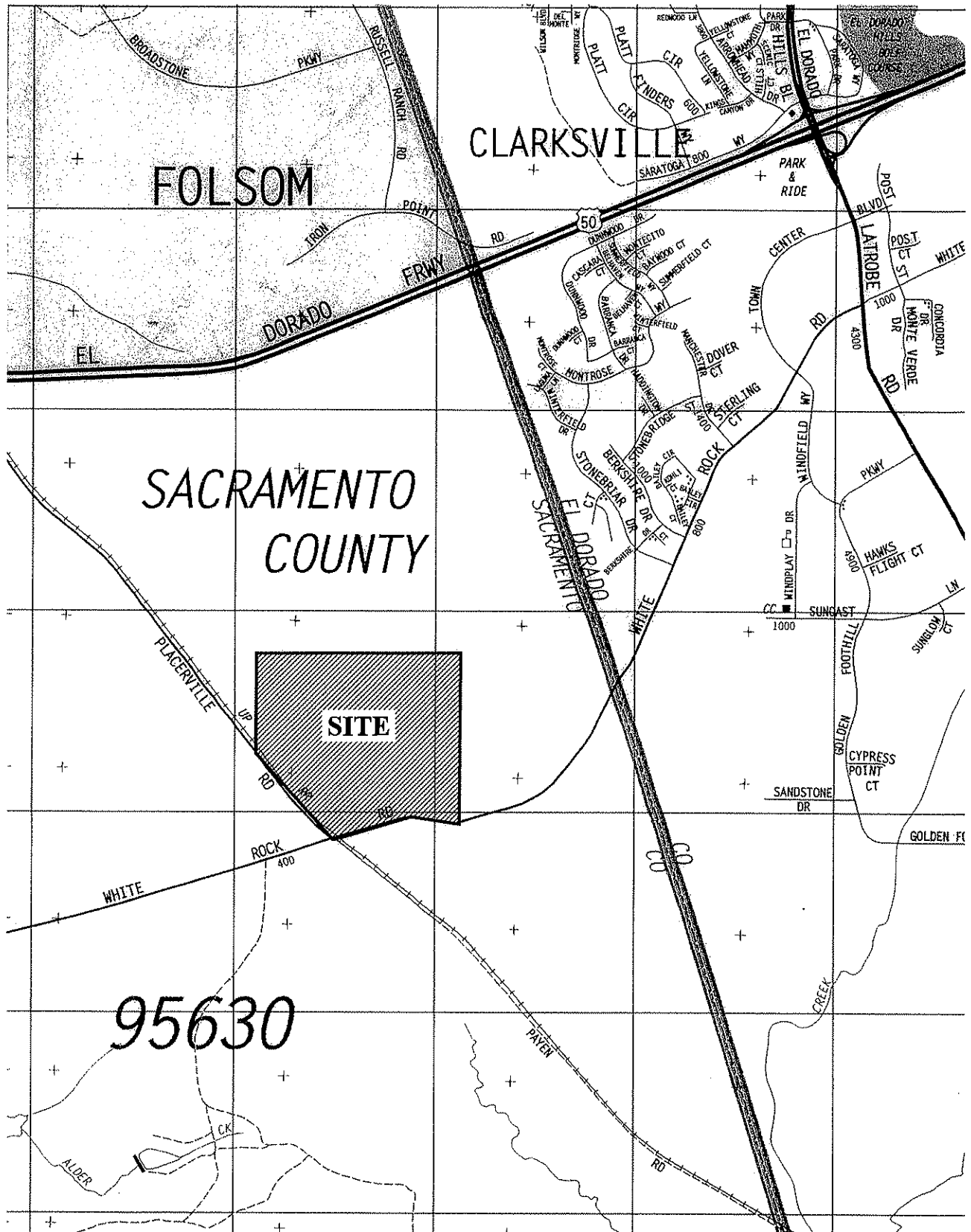

Adapted from the Thomas Guide
 Sacramento and Solano Counties
 Street Guide and Directory, 2002 edition.

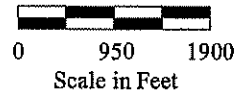

WALLACE • KUHL & ASSOCIATES, INC.
 GEOTECHNICAL ENGINEERING
 GEOLOGIC & ENVIRONMENTAL SERVICES

VICINITY MAP
FOLSOM 138 PROPERTY
 Sacramento, California

WKA NO: 6187.01
 DATE: 8/04
 PLATE NO: 1

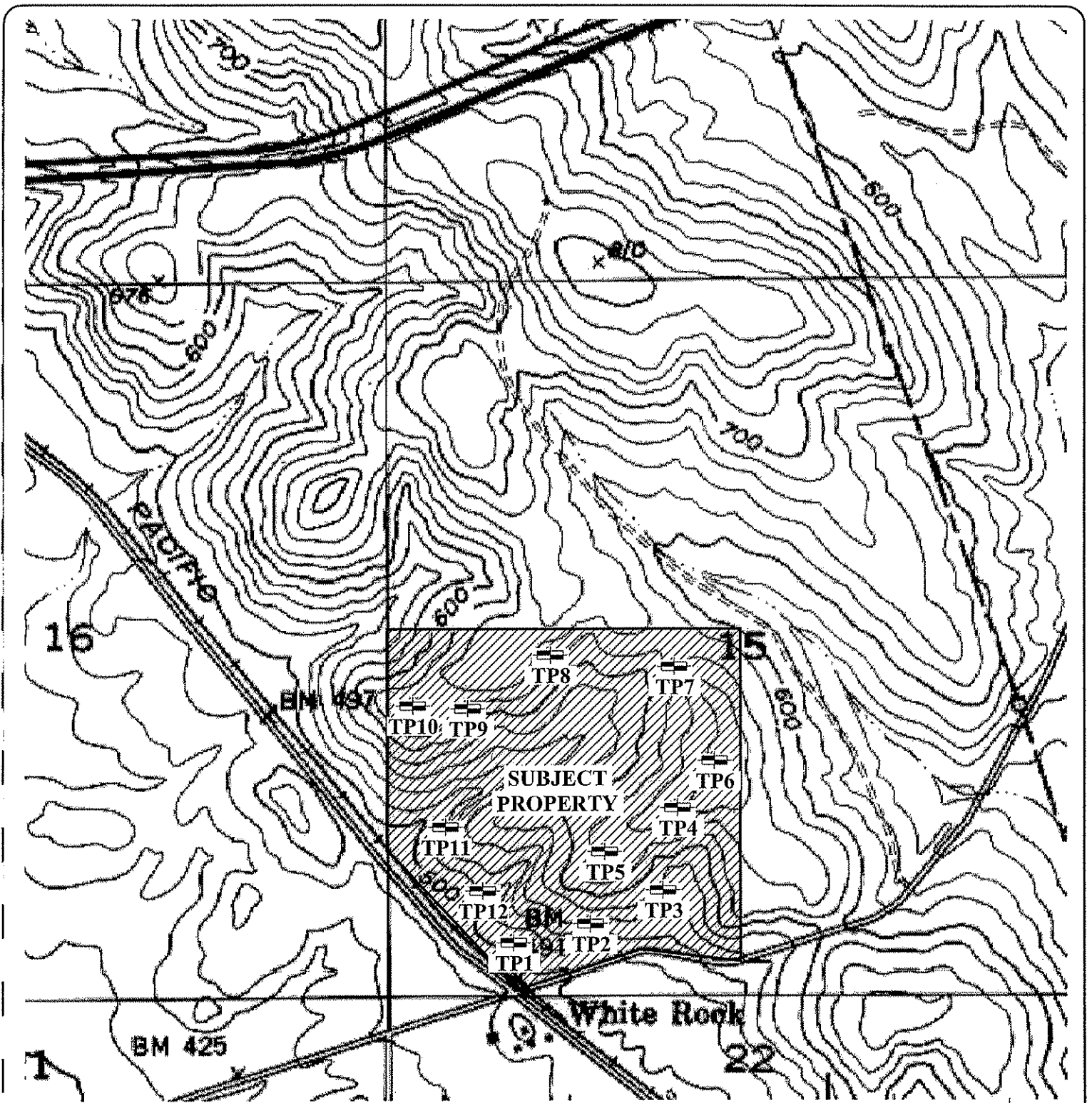

Legend:

 -Approximate Test pit locations

Adapted from the U.S. Geological Survey
7.5 minute topographic map of the Clarksville
quadrangle, California, 1980.

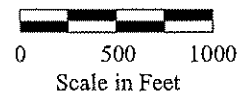

WALLACE • KUHL & ASSOCIATES, INC.
GEOTECHNICAL ENGINEERING
GEOLOGIC & ENVIRONMENTAL SERVICES

SITE PLAN

FOLSOM 138 PROPERTY
Sacramento County, California

WKA NO: 6187.01

DATE: 8/04

PLATE NO: 2

LOGS OF TEST PITS

TEST PIT 1

- 0 to 5' Reddish brown, very fine sandy silt (ML).
5' to 5½' Grayish brown, fine sandy, silty clay (CL).
5½' to 6' Dark greenish blue, very fine-grained metavolcanic rock (Rx).
Test pit terminated at 6 feet due to refusal.

TEST PIT 2

- 0 to 2½' Reddish brown, very fine sandy silt with trace quartz gravel (ML).
2½' to 9½' Greenish gray, highly weathered metavolcanic rock with clay infill (Rx).
Becomes less weathered with depth; after four feet, no clay infill. Wet fractured quartz veins observed below four feet.
Test pit terminated at 9½ feet due to refusal.
Perched water observed in quartz veins.

TEST PIT 3

- 0 to 3½' Reddish brown, very fine sandy silt (ML).
3½' to 7' Dark greenish blue, very fine-grained metavolcanic rock (Rx).
Excavated rock breaks into blocky cobble and gravel sized fragments.
Test pit terminated at seven feet due to refusal.

TEST PIT 4

- 0 to 2½' Reddish brown, very fine sandy silt (ML).
2½' to 8' Greenish gray/grayish blue, weathered very fine-grained metamorphic rock (Rx).
Excavated rock breaks into blocky cobble and gravel sized fragments.
Test pit terminated at eight feet due to refusal.

TEST PIT 5

- 0 to 1½' Reddish brown, gravelly, very fine sandy silt (ML).
1½' to 2½' Grayish, light blue unweathered metavolcanic rock (Rx).
Test pit terminated at 2½ feet due to refusal.

TEST PIT 6

- 0 to 1' Reddish brown, very fine sandy silt with gravel and cobble sized rock fragments (ML).
1' to 4' Greenish blue, weathered to non-weathered metavolcanic rock (Rx).
Becomes non-weathered below three feet.
Fracture plane dipping approximately 60 degrees to the southeast.
Test pit terminated at four feet due to refusal.



TEST PIT 7

- 0 to 2' Light reddish brown, very fine sandy silt (ML).
2' to 4' Brown, sandy silty clay/clayey silt (CL/ML).
4' to 7' Greenish blue, weathered to non-weathered metamorphic rock (Rx).
Test pit terminated at seven feet due to refusal.

TEST PIT 8

- 0 to 1½' Reddish brown, gravelly very fine sandy silt (ML).
1½' to 4' Greenish blue, weathered to non-weathered metavolcanic rock. (Rx).
Test pit terminated at four feet due to refusal.

TEST PIT 9

- 0 to ½' Reddish brown, fine sandy silt with cobble and gravel sized rock fragments (ML).
½' to 1' Reddish brown, fine sandy, silty, gravel with cobble sized rock fragments(GM).
1' to 4' Greenish blue, fractured metavolcanic rock (Rx).
Rock excavates into blocky, cobble sized fragments.
Fracture plane near vertical and oriented to the southwest.
Test pit terminated at four feet due to refusal.

TEST PIT 10

- 0 to 1½' Reddish brown, gravelly, very fine sandy silt (ML).
1½' to 3½' Dark blue metavolcanic rock (Rx)
Test pit terminated at 3½ feet due to refusal.

TEST PIT 11

- 0 to 2' Light reddish brown, very fine sandy silt (ML).
2' to 8' Gray, highly weathered metavolcanic rock (Rx).
8' to 9' Dark blue and green metasedimentary rock (Rx).
Test pit terminated at nine feet due to refusal.

TEST PIT 12

- 0 to 1½' Light reddish brown, very fine sandy silt (ML).
1½' to 5' Gray, highly weathered metamorphic rock (Rx).
5' to 6' Dark blue and green metasedimentary rock (Rx).
Test pit terminated at six feet due to refusal.



UNIFIED SOIL CLASSIFICATION SYSTEM

| MAJOR DIVISIONS | | SYMBOL | CODE | TYPICAL NAMES |
|--|---|--------|------|--|
| COARSE GRAINED SOILS (More than 50% of soil > no. 200 sieve size) | GRAVELS (More than 50% of coarse fraction > no. 4 sieve size) | GW | | Well graded gravels or gravel - sand mixtures, little or no fines |
| | | GP | | Poorly graded gravels or gravel - sand mixtures, little or no fines |
| | | GM | | Silty gravels, gravel - sand - silt mixtures |
| | | GC | | Clayey gravels, gravel - sand - clay mixtures |
| | SANDS (50% or more of coarse fraction < no. 4 sieve size) | SW | | Well graded sands or gravelly sands, little or no fines |
| | | SP | | Poorly graded sands or gravelly sands, little or no fines |
| | | SM | | Silty sands, sand - silt mixtures |
| | | SC | | Clayey sands, sand - clay mixtures |
| FINE GRAINED SOILS (50% or more of soil < no. 200 sieve size) | SILTS & CLAYS <u>LL < 50</u> | ML | | Inorganic silts and very fine sands, rock flour, silty or clayey fine sands or clayey silts with slight plasticity |
| | | CL | | Inorganic clays of low to medium plasticity, gravelly clays, sandy clays, silty clays, lean clays |
| | | OL | | Organic silts and organic silty clays of low plasticity |
| | SILTS & CLAYS <u>LL ≥ 50</u> | MH | | Inorganic silts, micaceous or diatomaceous fine sandy or silty soils, elastic silts |
| | | CH | | Inorganic clays of high plasticity, fat clays |
| | | OH | | Organic clays of medium to high plasticity, organic silty clays, organic silts |
| HIGHLY ORGANIC SOILS | | Pt | | Peat and other highly organic soils |
| ROCK | | RX | | Rocks, weathered to fresh |

OTHER SYMBOLS

| | |
|-------------------------|---|
| | = Drive Sample: 2-1/2" O.D. Modified California sampler |
| | = Drive Sample: no recovery |
| | = Initial Water Level |
| | = Final Water Level |
| - - - - - | = Estimated or gradational material change line |
| ————— | = Observed material change line |
| <u>Laboratory Tests</u> | |
| PI | = Plasticity Index |
| EI | = Expansion Index |
| UCC | = Unconfined Compression Test |
| TR | = Triaxial Compression Test |
| GR | = Gradational Analysis (Sieve) |
| K | = Permeability Test |

GRAIN SIZE CLASSIFICATION

| CLASSIFICATION | RANGE OF GRAIN SIZES | |
|--|--|--|
| | U.S. Standard Sieve Size | Grain Size in Millimeters |
| BOULDERS | Above 12" | Above 305 |
| COBBLES | 12" to 3" | 305 to 76.2 |
| GRAVEL coarse (c) fine (f) | 3" to No. 4 3" to 3/4" 3/4" to No. 4 | 76.2 to 4.76 76.2 to 19.1 19.1 to 4.76 |
| SAND coarse (c) medium (m) fine (f) | No. 4 to No. 200 No. 4 to No. 10 No. 10 to No. 40 No. 40 to No. 200 | 4.76 to 0.074 4.76 to 2.00 2.00 to 0.420 0.420 to 0.074 |
| SILT & CLAY | Below No. 200 | Below 0.074 |



WALLACE • KUHL & ASSOCIATES, INC.
GEOTECHNICAL ENGINEERING
GEOLOGIC & ENVIRONMENTAL SERVICES

UNIFIED SOIL CLASSIFICATION SYSTEM

FOLSOM 138 PROPERTY
Sacramento County, California

WKA NO: 6187.01

DATE: 8/04

PLATE NO: 5

APPENDIX A



APPENDIX A

A. GENERAL INFORMATION

The preparation of a preliminary geotechnical engineering report for the Folsom 138 Property, located on the north side of White Rock Road, south of Highway 50 in Sacramento County, California, was authorized by Mr. Jim Galovan with Woodside Homes of California, on August 5, 2004. Authorization was for an investigation as described in our proposal letter of August 4, 2004, sent to our client, Woodside Homes of California-Northern Division, whose mailing address is 111 Woodmere Drive, Suite 190, Folsom, California 95630; telephone (916) 608-9600 facsimile (916) 608-9970.

In performing this investigation we made reference to the USGS *Topographic Map of the Clarksville Quadrangle, California* (photorevised 1980) showing the project area provided by the client.

B. FIELD EXPLORATION

As indicated on Plate No. 2, twelve exploratory test pits were excavated across the property on August 11, 2004, to a maximum depth of approximately 9½ feet below existing site grades. The test pits were excavated with a Case 580 E rubber-tired backhoe utilizing a 12-inch wide bucket.

Bulk samples of the near-surface soils were obtained for expansion index testing and testing to determine pavement design parameters. All samples were taken to our laboratory for soil classification and selection of samples for testing. The Logs of Test Pits, Plates No. 3 and 4, contain descriptions of the soils encountered in each test pit. A legend explaining the Unified Soil Classification System used on the logs is contained on Plate No. 5.

C. LABORATORY TESTING

Two bulk samples of near-surface soil were subjected to Expansion Index testing (ASTM D4829); the result of these tests are presented on Plates No. A1 and A2.

Three bulk samples of anticipated pavement subgrade soil was subjected to Resistance-value ("R") testing in accordance with California Test 301. The results of the R-value tests are presented on Plates No. A3 through A5.

Three near-surface soil samples was submitted to Sunland Analytical to determine the soil pH and minimum resistivity (CT 643), sulfate concentration (CT 417) and chloride concentration (CT 422). Results from these tests are presented on Plates No. A6 through A8.



EXPANSION INDEX TEST RESULTS

UBC Standard No. 29-2

ASTM D4829-88

MATERIAL DESCRIPTION: Brown, fine sandy, silty clay

LOCATION: TP1

| Sample Depth | Pre-Test Moisture (%) | Post-Test Moisture (%) | Dry Density (pcf) | Expansion Index * |
|--------------|-----------------------|------------------------|-------------------|-------------------|
| 5' | 13.0 | 30.0 | 97 | 81 |

CLASSIFICATION OF EXPANSIVE SOIL **

| EXPANSION INDEX | POTENTIAL EXPANSION |
|-----------------|---------------------|
| 0 - 20 | Very Low |
| 21 - 50 | Low |
| 51 - 90 | Medium |
| 91 - 130 | High |
| Above 130 | Very High |

* Corrected to 50% Saturation

** From UBC Table 29-C

anomaly - not much clay here. Expansion Index # probably much lower for most of site.



WALLACE • KUHL & ASSOCIATES, INC.
 GEOTECHNICAL ENGINEERING
 GEOLOGIC & ENVIRONMENTAL SERVICES

EXPANSION INDEX
 FOLSOM 138 PROPERTY
 Sacramento County, California

WKA NO: 6187.01
 DATE: 8/04
 PLATE NO: A1

EXPANSION INDEX TEST RESULTS

UBC Standard No. 29-2

ASTM D4829-88

MATERIAL DESCRIPTION: Brown, fine sandy silt

LOCATION: TP4

| <u>Sample Depth</u> | <u>Pre-Test Moisture (%)</u> | <u>Post-Test Moisture (%)</u> | <u>Dry Density (pcf)</u> | <u>Expansion Index *</u> |
|---------------------|------------------------------|-------------------------------|--------------------------|--------------------------|
| 2' | 11.4 | 21.3 | 109 | 40 |

CLASSIFICATION OF EXPANSIVE SOIL **

| EXPANSION INDEX | POTENTIAL EXPANSION |
|-----------------|---------------------|
| 0 - 20 | Very Low |
| 21 - 50 | Low |
| 51 - 90 | Medium |
| 91 - 130 | High |
| Above 130 | Very High |

* Corrected to 50% Saturation

** From UBC Table 29-C



WALLACE • KUHL & ASSOCIATES, INC.
 GEOTECHNICAL ENGINEERING
 GEOLOGIC & ENVIRONMENTAL SERVICES

EXPANSION INDEX
 FOLSOM 138 PROPERTY
 Sacramento County, California

WKA NO: 6187.01

DATE: 8/04

PLATE NO: A2

RESISTANCE VALUE TEST RESULTS (California Test 301)

MATERIAL DESCRIPTION: Reddish brown, very fine sandy silt

LOCATION: TP3 (0-2')

| Specimen No. | Dry Unit Weight (pcf) | Moisture @ Compaction (%) | Exudation Pressure (psi) | Expansion Pressure | | R Value |
|-----------------|-----------------------------|---------------------------------|--------------------------------|--------------------|-------|------------|
| | | | | (dial) | (psf) | |
| 1 | 119 | 15.0 | 271 | 7 | 30 | 17 |
| 2 | 125 | 14.6 | 366 | 11 | 48 | 30 |
| 3 | 127 | 14.1 | 510 | 12 | 52 | 38 |

R-Value at 300 psi exudation pressure = 24



WALLACE • KUHL & ASSOCIATES, INC.
GEOTECHNICAL ENGINEERING
GEOLOGIC & ENVIRONMENTAL SERVICES

RESISTANCE VALUE
FOLSOM 138 PROPERTY
Sacramento County, California

WKA NO: 6187.01
DATE: 8/04
PLATE NO: A3

RESISTANCE VALUE TEST RESULTS (California Test 301)

MATERIAL DESCRIPTION: Light reddish brown, very fine sandy silt

LOCATION: TP11 (1'-2')

| Specimen No. | Dry Unit Weight (pcf) | Moisture @ Compaction (%) | Exudation Pressure (psi) | Expansion Pressure | | R Value |
|-----------------|-----------------------------|---------------------------------|--------------------------------|--------------------|-------|------------|
| | | | | (dial) | (psf) | |
| 1 | 110 | 18.9 | 135 | 8 | 35 | 7 |
| 2 | 115 | 16.2 | 279 | 22 | 95 | 12 |
| 3 | 117 | 15.4 | 398 | 60 | 260 | 41 |

R-Value at 300 psi exudation pressure =17



WALLACE • KUHL & ASSOCIATES, INC.
GEOTECHNICAL ENGINEERING
GEOLOGIC & ENVIRONMENTAL SERVICES

RESISTANCE VALUE
FOLSOM 138 PROPERTY
Sacramento County, California

WKA NO: 6187.01

DATE: 8/04

PLATE NO: A4

RESISTANCE VALUE TEST RESULTS (California Test 301)

MATERIAL DESCRIPTION: Brown, sandy silty clay/clayey silt

LOCATION: TP7 (2'-3')

| Specimen No. | Dry Unit Weight (pcf) | Moisture @ Compaction (%) | Exudation Pressure (psi) | Expansion Pressure | | R Value |
|-----------------|-----------------------------|---------------------------------|--------------------------------|--------------------|-------|------------|
| | | | | (dial) | (psf) | |
| 1 | 106 | 23.4 | 550 | 40 | 173 | - |
| 2 | 101 | 25.3 | 350 | 20 | 91 | - |

Sample extruded therefore R-value = 5



WALLACE • KUHL & ASSOCIATES, INC.
GEOTECHNICAL ENGINEERING
GEOLOGIC & ENVIRONMENTAL SERVICES

RESISTANCE VALUE
FOLSOM 138 PROPERTY
Sacramento County, California

WKA NO: 6187.01

DATE: 8/04

PLATE NO: A5

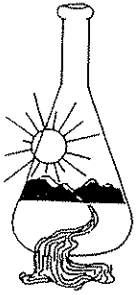

Sunland Analytical

11353 Pyrites Way, Suite 4
Rancho Cordova, CA 95670
(916) 852-8557

Date Reported 08/18/2004
Date Submitted 08/12/2004

To: David Perry
Wallace-Kuhl & Associates
3050 Industrial Blvd.
West Sacramento, CA 95691

From: Gene Oliphant, Ph.D. \ Randy Horney
General Manager \ Lab Manager

The reported analysis was requested for the following location:
Location : 6187.01\FOLSOM 138 Site ID : TP-3.
Your purchase order number is 9132.
Thank you for your business.

* For future reference to this analysis please use SUN # 42748-83715.

EVALUATION FOR SOIL CORROSION

| | | | |
|---------------------|---------|----------------|--|
| Soil pH | 6.33 | free. | (Below 5.5, per Cal Trans, risk of corrosion of cement slab) |
| Minimum Resistivity | 3.48 | ohm-cm (x1000) | |
| Chloride | 8.0 ppm | 00.00080 % | |
| Sulfate | 1.7 ppm | 00.00017 % | |

METHODS

pH and Min. Resistivity CA DOT Test #643
Sulfate CA DOT Test #417, Chloride CA DOT Test #422



WALLACE • KUHL & ASSOCIATES, INC.
GEOTECHNICAL ENGINEERING
GEOLOGIC & ENVIRONMENTAL SERVICES

CORROSION TEST

FOLSOM 138 PROPERTY
Sacramento County, California

WKA NO: 6187.01

DATE: 8/04

PLATE NO: A6

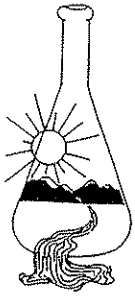

Sunland Analytical

11353 Pyrites Way, Suite 4
Rancho Cordova, CA 95670
(916) 852-8557

Date Reported 08/18/2004
Date Submitted 08/12/2004

To: David Perry
Wallace-Kuhl & Associates
3050 Industrial Blvd.
West Sacramento, CA 95691

From: Gene Oliphant, Ph.D. \ Randy Horney
General Manager \ Lab Manager

The reported analysis was requested for the following location:
Location : 6187.01\FOLSOM 138 Site ID : TP-4.
Your purchase order number is 9132.
Thank you for your business.

* For future reference to this analysis please use SUN # 42748-83716.

EVALUATION FOR SOIL CORROSION

| | | | |
|---------------------|---------|----------------|---|
| Soil pH | 6.08 | | |
| Minimum Resistivity | 2.55 | ohm-cm (x1000) | |
| Chloride | 6.0 ppm | 00.00060 | % |
| Sulfate | 0.6 ppm | 00.00006 | % |

METHODS

pH and Min.Resistivity CA DOT Test #643
Sulfate CA DOT Test #417, Chloride CA DOT Test #422



WALLACE • KUHL & ASSOCIATES, INC.
GEOTECHNICAL ENGINEERING
GEOLOGIC & ENVIRONMENTAL SERVICES

CORROSION TEST
FOLSOM 138 PROPERTY
Sacramento County, California

WKA NO: 6187.01
DATE: 8/04
PLATE NO: A7

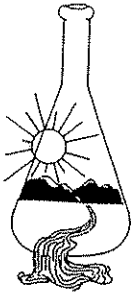

Sunland Analytical

11353 Pyrites Way, Suite 4
Rancho Cordova, CA 95670
(916) 852-8557

Date Reported 08/18/2004
Date Submitted 08/12/2004

To: David Perry
Wallace-Kuhl & Associates
3050 Industrial Blvd.
West Sacramento, CA 95691

From: Gene Oliphant, Ph.D. \ Randy Horney
General Manager \ Lab Manager

The reported analysis was requested for the following location:
Location : 6187.01\FOLSOM 138 Site ID : TP-1.
Your purchase order number is 9132.
Thank you for your business.

* For future reference to this analysis please use SUN # 42748-83717.

EVALUATION FOR SOIL CORROSION

| | | | |
|---------------------|---------|---------------------------------|---|
| Soil pH | 5.54 | <i>a bit low, but still ok.</i> | |
| Minimum Resistivity | 3.22 | ohm-cm (x1000) | |
| Chloride | 5.6 ppm | 00.00056 | % |
| Sulfate | 1.3 ppm | 00.00013 | % |

METHODS

pH and Min.Resistivity CA DOT Test #643
Sulfate CA DOT Test #417, Chloride CA DOT Test #422



WALLACE • KUHL & ASSOCIATES, INC.
GEOTECHNICAL ENGINEERING
GEOLOGIC & ENVIRONMENTAL SERVICES

CORROSION TEST
FOLSOM 138 PROPERTY
Sacramento County, California

WKA NO: 6187.01

DATE: 8/04

PLATE NO: A8

APPENDIX F3

Preliminary Geotechnical Engineering Report –
Folsom Heights

**PRELIMINARY
GEOTECHNICAL
ENGINEERING REPORT**

FOLSOM HEIGHTS

**WKA No.
6744.02**

**August 19,
2005**



**WALLACE - KUHL
& ASSOCIATES INC.**

Geotechnical Engineering

Engineering Geology

Environmental Consulting

Remediation Services

Construction Inspection

Materials Testing

Preliminary Geotechnical Engineering Report

FOLSOM HEIGHTS

White Rock Road

Sacramento County, California

WKA No. 6744.02

August 19, 2005

INTRODUCTION

General

We have completed a preliminary geotechnical engineering evaluation of the Folsom Heights Property, located in eastern Sacramento County, California. Our work has been performed in accordance with verbal authorization on July 28, 2005 from Centex Homes, and the scope of work outlined in our proposal letter dated August 3, 2005. Wallace Kuhl & Associates is concurrently preparing an Environmental Site Assessment for the Folsom Heights Property (WKA No. 6744.01), which will be issued separately. Wallace-Kuhl & Associates prepared a *Preliminary Geotechnical Engineering Report* for the Folsom 1400 Property (WKA No. 6449.02, dated March 23, 2005) located adjacent to the west of the Folsom Heights Property. Information obtained during that investigation was used to assist in the preparation of this report.

Scope

Our scope of work included the following tasks:

1. review of historic USGS topographic maps, geologic maps and aerial photographs of the property;
2. geologic reconnaissance by a Professional Geologist;
3. subsurface investigation, including the excavation and sampling of eight test pits to a maximum depth of approximately 10 feet below the ground surface;
4. laboratory testing of selected soil samples;

CORPORATE OFFICE
3050 Industrial Boulevard
West Sacramento
CA 95691
Tel 916.372.1434
Fax 916.372.2565

ROCKLIN OFFICE
500 Menlo Drive
Suite 100
Rocklin, CA 95765
Tel 916.435.9722
Fax 916.435.9822

STOCKTON OFFICE
3410 West Hammer Lane
Suite F
Stockton, CA 95219
Tel 209.234.7722
Fax 209.234.7727

5. engineering analyses; and,
6. preparation of this report.

Plates and Attachments

Our report contains a Geologic Map (Plate No. 1); a Site Plan showing approximate test pit locations (Plate No. 2); and, Logs of Test Pits (Plates No. 3 and 4). An explanation of the classification system used on the logs is included on Plate No. 5. Appendix A contains general information regarding project concepts, exploratory methods used during our field investigation, and a summary of laboratory test results.

Project Description

We understand the site will be primarily developed with single-family residential subdivisions. Due to the gently rolling terrain we anticipate that both graded pads and natural lots will be created during development. We assume typical construction will consist of one- and two-story, wood-frame residences, with interior concrete slabs-on-grade and/or raised-wood floors. Associated development will include underground utilities and interior roadways. Due to the relatively steep terrain we anticipate excavations in the range of 5 to 10 feet for general grading, with considerably deeper excavations for underground utilities.

FINDINGS

Site Conditions

The Folsom Heights Property is located south of Highway 50, adjacent to the El Dorado/Sacramento County line in eastern Sacramento County, California. The majority of the property is located southwest of the intersection of the El Dorado/Sacramento County line and Highway 50, although a small panhandle-shaped portion of the property extends southeast along the El Dorado/Sacramento County line to White Rock Road (See Plates No. 1 and 2). The site is bound by Highway 50 to the north; the El Dorado/Sacramento County line to the east, beyond which is an existing residential subdivisions; open undeveloped land and White Rock Road to the south; and open undeveloped land to the west. Topography of the property is undulating to



moderately and steeply rolling terrain with surface elevations ranging between approximately +540 feet to +810 feet relative to mean sea level (msl), based on review of a topographic map provided by MacKay & Sumps and the USGS *Topographic Map of the Clarksville Quadrangle, California* (photorevised 1980).

At the time of our site reconnaissance, August 11, 2005, the site was covered with native weeds and grasses and was undeveloped. An antenna tower is located along the western perimeter of the site close to the cluster of towers located on the adjacent site. Rock outcrops were visible across much of the higher elevation portion of the site. Dry to moist seasonal creeks meander across the northeastern portion of the property, which is the lowest portion of the site.

In the vicinity of Test Pit No. 4 we observed several mature Cottonwood trees and green grass. Two rock lined water wells approximately three feet in diameter were observed near the Cottonwood trees. Both wells were full of water and had a slow but steady stream of water flowing from them. The water drained from the well by PVC pipe into cattle watering troughs and the troughs were slowly overflowing. The overflowing water resulted in the area around the trees being saturated with several areas of ponding water.

Review of available aerial photographs taken in 1962, 1971, 1976, 1989 and 2001 indicates the property has been undeveloped and used for grazing during at least this period of time. The telecommunication towers located west of the property been in existence since before 1962, the tower located on the Folsom Heights property has been in existence since sometime after 1989.

Site Geology

The property is predominately underlain by metavolcanic and pyroclastic rock formations as identified by the California Department of Conservation: Mines and Geology publication, "Generalized Geologic Map of the Folsom 15-Minute Quadrangle." Based on this map, the Copper Hill Volcanic formation appears to cover the entire property, consisting of mostly mafic to andesitic pyroclastic rocks, lava, and pillow lava, with subordinate felsic porphyritic and pyroclastic rocks.

The *Generalized Geology Map of the Folsom 15-Minute Quadrangle* indicates the west branch of the Bear Mountains Fault is located approximately 6000 feet east of the Folsom Heights

Property, and represents the westernmost fault within the "Foothills Fault Zone." The site is not identified within a *Alquist-Priolo Fault Study Zone*, meaning that the State has not identified this portion of the Foothills Fault Zone as being active within the last 11,000 years. The Bear Mountains Fault is mapped as a pre-Quaternary fault (not active within the last 1.6 million years), except for the "Rescue Lineament," which may have been active in late Quaternary time. The Rescue Lineament is located about 9 miles northeast of the eastern boundary of the site.

Subsurface Conditions

Our site reconnaissance and test pits indicate a subsurface profile of very fine sandy silts, silty clays and sandy clays with variable rock fragments at the surface, underlain by weathered to unweathered metavolcanic rocks. The weathered metavolcanic rock excavated into gravel to cobble sized angular rock pieces. Weathering of the metavolcanic rock decreases with depth. Test Pit No. 4 encountered cemented sandstone below three feet. Please review the Logs of Test Pits (Plates No. 3 and 4) for information on soil and rock conditions at specific locations.

Review of the 1980 U.S. Department of Agriculture, Soil Conservation Service (SCS) *Soil Survey of Sacramento County, California* indicates that the near-surface soils on the subject property consist of two different soils types, including the "Argonaut-Auburn complex, 3 to 8 percent slopes," and "Argonaut-Auburn outcrop complex, 8 to 30 percent slopes." The majority of the site is composed of Argonaut-Auburn outcrop complex with the exception of the lower valley area in the northeastern corner of the site.

- The Argonaut profile typically consists of material weathered from metaandesite and metamorphic rocks. Typically, the surface layer is reddish yellow and light yellowish brown loam about 8 inches thick. The upper 6 inches of the subsoil is yellowish red gravelly loam. The lower 15 inches is a claypan of variegated strong brown yellowish brown, and yellowish red clay and clay loam. Highly weathered metavolcanic rock is at a depth of about 29 inches.
- Auburn profile typically consists of material weathered from metaandesite and metamorphic rocks. Typically the surface layer and subsoil are strong brown, reddish yellow, and yellowish red loam. Fractured metabasic bedrock is at a depth of about 14 inches.

These soils formed as alluvium derived from mixed-rock sources, and these soil units are reportedly used for rangeland and dry-farmed crops. The SCS soil descriptions are generally consistent with our site observations and previous experience in the area.

Ground Water

Free ground water was not encountered in the test pits excavated on August 11, 2005. However, flowing water was observed in the two wells observed near Test Pit No. 4. The water in these wells may be the result of artesian springs conditions. Published data and experience in the vicinity of the project suggests that a permanent ground water table is at least 100 feet below the existing lower ground surfaces.

CONCLUSIONS

General

Our field and laboratory investigations indicate the Folsom Heights property is suitable for single-family residential development from the standpoint of soils and geologic considerations. Earth materials are considered to have no unusual or adverse engineering characteristics, which would preclude any of the elements of the proposed development. Of special concern to the development of this property will be the location of all wells, and the proper abandonment and backfilling of these features; the presence of highly expansive clays above the weathered rock; and the excavability of the underlying rock.

Seismic Considerations

No active or potentially active faults are known to underlie the Folsom Heights Property, based on the published geologic maps and aerial photographs that we reviewed. The site is not located within an Alquist-Priolo Fault Study Zone, and we observed no surface evidence of faulting during our site reconnaissance. Therefore, it is our opinion that ground rupture at the site resulting from seismic activity is unlikely.

According to the 2001 edition of the California Building Code (Title 24 of the California Code of Regulations, Chapter 16; California amendments to the 1997 edition of the Uniform Building Code) the site is located within Seismic Zone 3. A soil profile type S_C , as referenced in Table 16A-J of Chapter 16 of the 2001 California Building Code (CBC) is considered appropriate for this site. The project site is not located within 15 kilometers (km) of a Type A or Type B fault source, as defined by CBC Table 16A-U. Although the Bear Mountain Fault is located within 15 kilometers of the site it is not identified as a Type A or Type B fault.

Naturally Occurring Asbestos

The test pits completed during our geotechnical investigation of the Folsom Heights property revealed no ultramafic rocks, serpentine, or obvious evidence of naturally occurring asbestos (NOA). However, metavolcanic rocks of the Copper Hill Volcanics and Gopher Ridge Volcanics geologic units underlie a significant portion of the Folsom Heights property. The concurrent Environmental Site Assessment (WKA No. 6744.01) will address the NOA issues in more detail.

In September 2004, the Sacramento Metropolitan Air Quality Management District (SMAQMD) issued an advisory (Advisory #04-05 revised) that the potential exists for NOA to be encountered in rocks of the Copper Hill Volcanics geologic unit. Consequently, the SMAQMD currently requires that earthmoving activities performed in areas underlain by the Copper Hill Volcanics be performed in accordance with dust mitigation measures described in the California Air Resources Board's *Asbestos Airborne Toxic Control Measure for Construction, Grading, Quarrying, and Surface Mining Operations (ATCM)*. The SMAQMD requires that specific dust mitigation measures proposed for such projects must be outlined in an Asbestos Dust Mitigation Plan, which is to be approved by the SMAQMD prior to commencing earthmoving activities.

A project may be granted exemption from the ATCM requirements (by SMAQMD) if a geologic evaluation has been conducted by a Professional Geologist who makes a determination that asbestos does not exist in the area to be disturbed. To obtain a geologic exemption for projects within the specified geologic units, the SMAQMD currently requires that sampling and testing for NOA be performed in accordance with the California Air Resources Board Method 435 (CARB 435), which specifies testing of one three-point composite sample (one sample consisting of material from three different locations) per acre of land to be disturbed.

FOLSOM HEIGHTS

WKA No. 6744.02

August 19, 2005

Well Abandonment

Existing wells at the site should be destroyed in accordance with abandonment permits that would be issued by the Sacramento County Environmental Health Division.

Excavation Conditions

The subject site contains silty and rocky surface soils, underlain by variably weathered and fractured metavolcanic rock. The uppermost alluvial soils should be excavatable with conventional excavation equipment typically used in the area. The metamorphic rock will be more difficult to excavate, and likely will require large dozers and excavators or possibly blasting to achieve excavations. This could have a significant impact on site development costs if deep excavations, such as for utilities, are required.

In order to evaluate the excavation conditions or "rippability" of the underlying variably weathered and fractured metavolcanic rock materials at the site, we recommend (as part of a design level study) performing seismic refraction traverses at areas of the site planned for the deepest excavations. The results of a seismic refraction survey are useful in that they can be compared to excavation equipment performance charts to evaluate the ability of different sized equipment to rip or excavate the materials.

Soil Expansion Potential

Laboratory testing of the surface and near-surface clay soils indicates these materials possess a high expansion potentials when tested in accordance with the ASTM D4829 (UBC 29-2) test method (see Plates No. A1 and A2). Previous experience and laboratory testing on nearby projects also has revealed the clay soils directly above the weathered rock to be moderate to highly expansive. Use of expansive clays, if present, should be avoided within building pads fills, and when clays are exposed at subgrade level within excavation areas, they should be removed and replaced with low expansion materials.



Material Suitability

The native soils and weathered rock will be suitable for use as engineered fill, provided they do not contain significant concentrations of vegetation or debris, and they are at an appropriate moisture content to allow proper compaction. Clay soils should not be used near the surface of building pads, but will be suitable for use in deeper fills. However, experience suggests that the volume of clay in relation to rocky materials is relatively small, resulting in a mixture of materials that is not very expansive.

Deeper excavations likely may result in larger rocks that will not be suitable unless broken down into smaller fragments (say 12 inch maximum size) that can be properly incorporated into engineered fill and compacted.

Ground Water and Seepage

Although review of available ground water information suggests that the static ground water table should not adversely affect construction of the proposed residential improvements, seepage water is present in the vicinity of Test Pit No. 4, which was located near the base of the sloping terrain. This indicates seepage will need to be addressed during site development. Experience in the El Dorado Hills area indicates that seepage can be controlled with the construction of subdrainage. Typical subdrains consist of perforated pipe and gravel, surrounded by non-woven geotextile fabric. Design of subdrains should be performed during construction when actual seepage conditions are exposed; however, there should be a contingency fund in the project budget for subdrain construction.

Seasonal Water

The near-surface soils will be in a near-saturated condition during and for a considerable period following the rainy season. Grading operations attempted following the onset of winter rains and prior to prolonged drying periods will be hampered by high soil moisture contents. Such soils, intended for use as engineered fill, will require considerable aeration to reach a moisture content that will permit the recommended compaction to be achieved. The underlying weathered rock will not be as severely impacted by seasonal rains.

Preliminary Soil Corrosion Potential

Four composite samples of near-surface soils were submitted to Sunland Analytical for testing to determine pH, resistivity, sulfate and chloride concentrations to help evaluate the potential for corrosive attack upon buried structures. The test results for the samples revealed minimum resistivities of 860 to 3480 ohm-centimeters (Ω -cm) and a soil pH ranging from 6.22 to 7.25. Sulfates were recorded at 0.1 to 0.4 parts per million (ppm) and chlorides at 4.3 to 12.3 ppm. Results of the testing performed by Sunland Analytical are summarized on Plates No. A3 through A6.

Caltrans¹ considers a site to be corrosive to structural elements if one or more of the following conditions exist for the representative soil sample(s) taken at the site:

Chloride concentration is greater than or equal to 500 ppm, sulfate concentration is greater than or equal to 2000 ppm, or the pH is 5.5 or less.

Caltrans defines areas as either corrosive or non-corrosive based on the above information. Comparing this information to the test results indicates the native soils are non-corrosive to structural elements. Table 19-A-4 of the 1997 UBC, Requirements for Concrete Exposed to Sulfate-Containing Solutions, indicates the sulfate exposure for the samples tested are *Negligible*. Based on this table ordinary Type I-II Portland cement is indicated to be suitable for use on the project, assuming a minimum cover is maintained over the reinforcement.

Wallace-Kuhl & Associates are not corrosion engineers. Therefore, to further define the soil corrosion potential at the site a corrosion engineer should be consulted.

¹ California Department of Transportation, Division of Engineering Services, Materials Engineering and Testing Services, Corrosion Technology Branch, *Corrosion Guideline*, Version 1.0, September 2003.

PRELIMINARY RECOMMENDATIONS

Foundation Design and Floor Slab Support

The proposed residential structures likely can be supported upon continuous and/or isolated spread foundations extending at least 12 inches below lowest adjacent soil grade. The minimum 12 inch embedment also must be maintained with stepped foundations constructed on sloping lots. Foundations should be continuous around the perimeter of the buildings to help minimize moisture migration beneath the structures. A maximum allowable soil pressure of approximately 2500 psf for dead load plus live load with a 1/3 increase for consideration of seismic or wind forces is considered appropriate for preliminary foundation design. Foundations should be at least nominally reinforced.

Interior slab-on-grade concrete floors would be suitable for graded pads or relatively flat natural pads constructed at this site, provided slabs are properly designed and constructed with regard to moisture vapor penetration resistance and the slabs are adequately reinforced. Typical slab reinforcement would consist of flat sheets of welded-wire fabric (6x6/W2.9xW2.9) place on chairs or chaired No. 3 rebar at 24-inch center-to-center spacing. Due to placement issues during construction chaired rebar would be the preferred reinforcement.

Pavement Subgrade Quality

Due to the rolling site terrain, we anticipate that subgrade conditions will vary considerably. Laboratory testing of surface clayey soil from nearby projects indicates Resistance ("R") values of 5, which would be an appropriate design value for clay subgrades. Experience also suggests that subgrades consisting of weathered rock materials likely will possess an R-value of at least 40. Using these design values and the design traffic indices contained in the "Design Practice Guide" prepared by the Sacramento County Transportation Division, dated June 1, 1999, we have calculated the following preliminary pavement section alternatives. The procedures used for designing the pavement section are in general conformance with the "Flexible Pavement Structural Design Guide for California Cities and Counties" and applicable portions of the Caltrans Highway Design Manual.



Preliminary Pavement Alternates

Subgrade R-value = 40

| Street Right-of-Way | Traffic Index (TI) | Type B Asphalt Concrete (inches) | Class 2 Aggregate Base (inches) |
|--|--------------------|----------------------------------|---------------------------------|
| 40' and 50' Residential | 5.0 | 2½ | 5 |
| | | 3 | 4 |
| 56' to 74' without Bus Routes | 6.0 | 2½ | 8 |
| | | 3½* | 6 |
| 56' to 74' with Bus Routes and Cul-de-Sacs | 6.5 | 3 | 9 |
| | | 4* | 7 |
| 84' Streets | 9.0 | 4 | 12 |
| | | 5½* | 10 |
| 108' and 130' Streets | 10.0 | 5 | 14 |
| | | 6* | 12 |

* includes Caltrans safety factor

Preliminary Pavement Alternates

Subgrade R-value = 5

| Street Right-of-Way | Traffic Index (TI) | Type B Asphalt Concrete (inches) | Class 2 Aggregate Base (inches) |
|--|--------------------|----------------------------------|---------------------------------|
| 40' and 50' Residential | 5.0 | 2½ | 11 |
| | | 3 | 10 |
| 56' to 74' without Bus Routes | 6.0 | 2½ | 15 |
| | | 3½* | 13 |
| 56' to 74' with Bus Routes and Cul-de-Sacs | 6.5 | 3 | 17 |
| | | 4* | 15 |
| 84' Streets | 9.0 | 4 | 23 |
| | | 5½* | 21 |
| 108' and 130' Streets | 10.0 | 5 | 26 |
| | | 6* | 24 |

*includes Caltrans safety factor

Future Studies

This report is intended to provide an overview of the suitability of the site for residential development. Prior to further development, detailed subsurface investigations of the properties, including additional borings and/or test pits, and seismic traverses should be performed, along with a more extensive laboratory testing program, and geotechnical reports prepared presenting specific conclusions and recommendations for design and construction of the various phases of the project.

LIMITATIONS



The proceeding sections of this report should be considered a general overview of the geotechnical engineering aspects of site development. They are not intended for specific design or construction of any of the project improvements. At an appropriate time prior to development, our firm should be retained to conduct a comprehensive, site specific geotechnical engineering investigation for this project.

We appreciate this opportunity to be of service. Please contact our office if you have any questions regarding our report or the geotechnical aspects of site development.

Wallace-Kuhl and Associates, Inc.



David L. Perry
Project Geologist

Stephen L. French
Senior Engineer

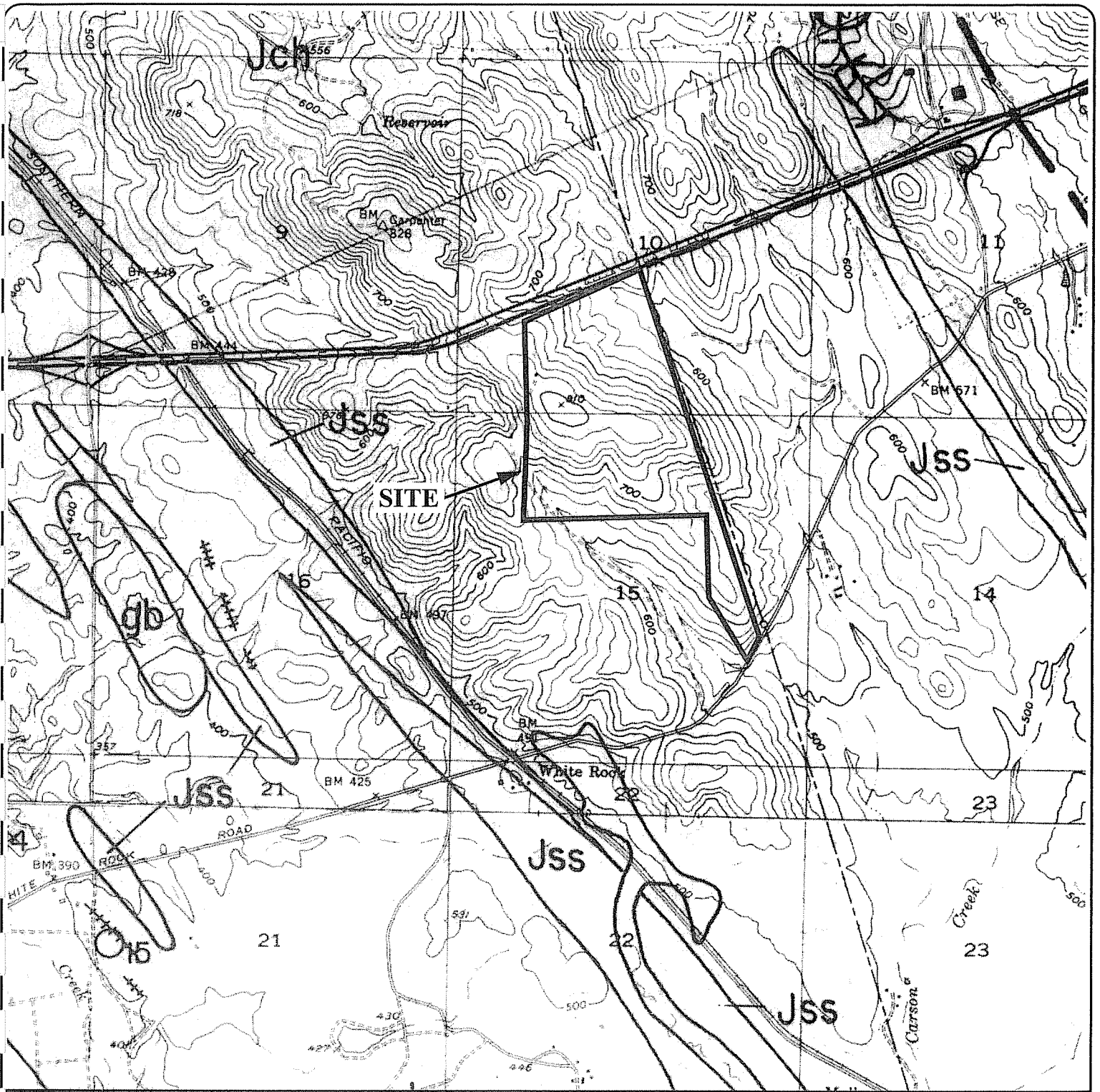

Adapted from Loyd, 1984.

Legend:

- Jch- Copper Hills Volcanics
- Jss- Salt Springs Slate
- Jgo- Gopher Ridge Volcanics
- gb- Gabbroic

Map Symbols:

- +++ Quartz Veins
- Gold, Lode

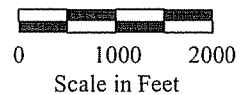

WALLACE • KUHL & ASSOCIATES, INC.
 GEOTECHNICAL ENGINEERING
 GEOLOGIC & ENVIRONMENTAL SERVICES

GEOLOGIC MAP
FOLSOM HEIGHTS

Sacramento County, California

WKA NO: 6744.02

DATE: 8/05

PLATE NO: 1

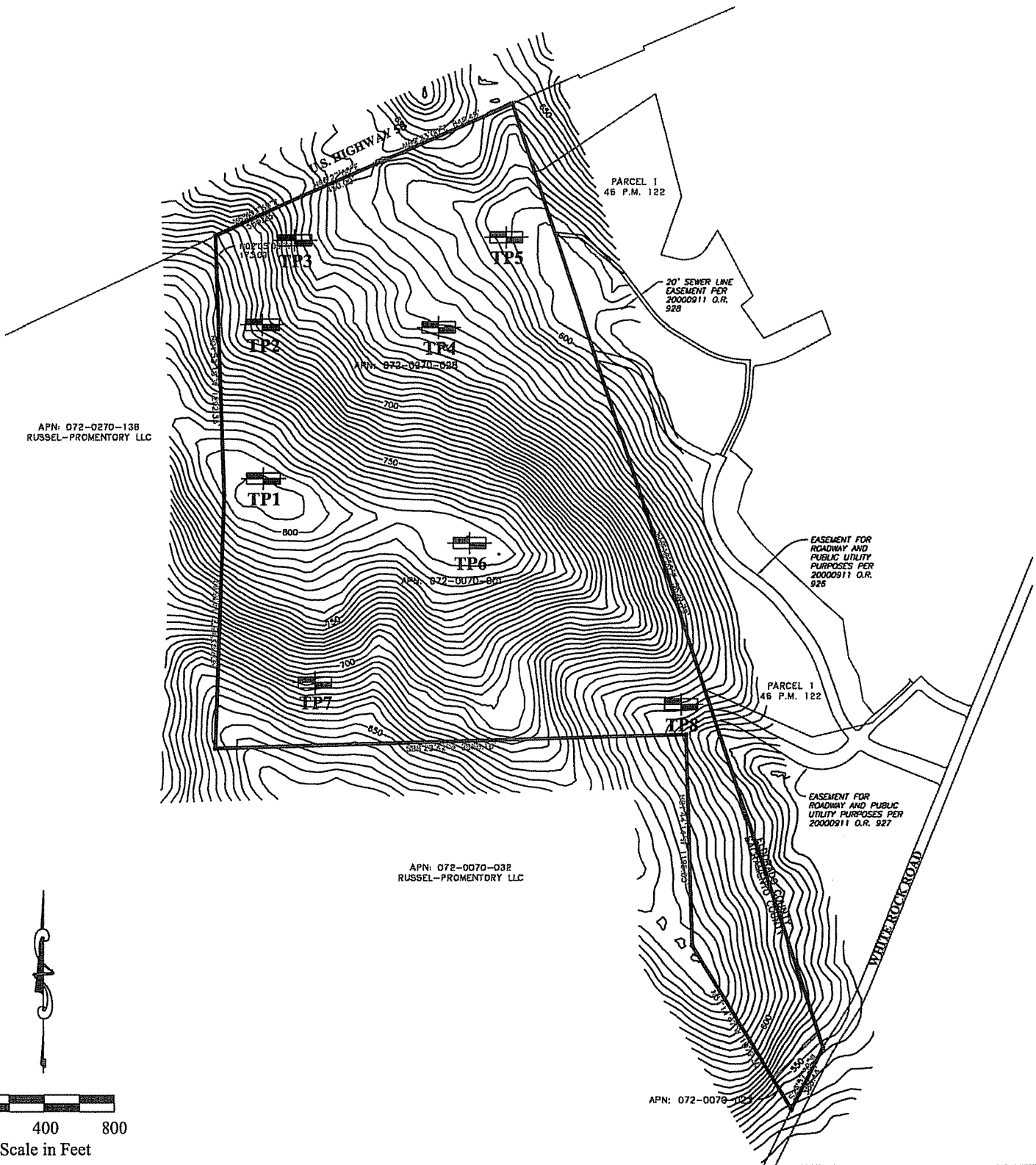

Note:

Adapted from a CAD drawing from MacKay & Soms, dated August 8, 2005

Legend:



Approximate test pit location



WALLACE • KUHL & ASSOCIATES, INC.
 GEOTECHNICAL ENGINEERING
 GEOLOGIC & ENVIRONMENTAL SERVICES

SITE PLAN
FOLSOM HEIGHTS
 Sacramento County, California

WKA NO: 6744.02
 DATE: 8/05
 PLATE NO: 2

LOGS OF TEST PITS

TEST PIT 1

- 0 to 3' Reddish brown, fine sandy silt with angular gravel to cobble sized weathered metavolcanic rock fragments (ML)
Bulk sample from surface to 1 foot
- 3' to 3½' Yellowish brown, silty fine sand with gravel to cobble sized angular weathered metavolcanic rock fragments (SM)
- 3½' to 4' Brownish green, metavolcanic rock with yellowish brown weathering (Rx)
Test pit terminated at 4 feet due to refusal

TEST PIT 2

- 0 to 1' Reddish brown, fine sandy silt with angular gravel to cobble sized weathered metavolcanic rock fragments (ML)
- 1' to 7' Yellowish brown, silty fine sand with gravel to cobble sized angular weathered metavolcanic rock (SM)
- 7' to 8½' Brownish green, metavolcanic rock with yellowish brown weathering (Rx)
Test pit terminated at 8½ feet due to refusal

TEST PIT 3

- 0 to 2' Reddish brown, very fine sandy silt with trace gravel (ML)
- 2' to 4' Yellowish brown, silty fine sand with gravel to cobble sized angular weathered metavolcanic rock fragments (SM)
- 4' to 5' Greenish blue, metavolcanic rock with a yellowish brown weathering surface (Rx)
Test pit terminated at 5 feet due to refusal

TEST PIT 4

- 0 to 1' Reddish brown, very fine sandy silt (ML)
- 1' to 5' Grayish brown, silty clay (CL)
Gravel to cobble sized inclusions below 3 feet
Bulk sample from 1 to 3 feet
- 5' to 5½' Greenish blue, weathered to non-weathered metavolcanic rock in a yellowish brown sandy matrix (RX)
Weathered rock excavates into gravel to cobble sized angular pieces
Test pit terminated at 5½ feet due to refusal



LOGS OF TEST PITS

TEST PIT 5

- 0 to 1' Dark brown, silty clay (CL)
Bulk sample from 0 to 1 foot
- 1' to 6' Yellowish brown, clayey sandy silt (ML)
Trace gravel and cobble sized metavolcanic rock fragments below 3 feet
- 6' to 8½' Light brown, weathered, metavolcanic rock (Rx)
- 8½' to 9½' Greenish blue, metavolcanic rock with a yellowish brown weathering surface (Rx)
Test pit terminated at 9½ feet due to refusal

TEST PIT 6

- 0 to 2' Reddish brown, silty fine sand with angular gravel to cobble sized weathered metavolcanic rock fragments (SM)
- 2' to 4' Yellowish brown, silty fine sand with gravel to cobble sized angular weathered metavolcanic rock fragments (SM)
- 4' to 5' Greenish blue, metavolcanic rock with a yellowish brown weathering surface (Rx)
Test pit terminated at 5 feet due to refusal

TEST PIT 7











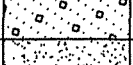

- 0 to 2' Reddish brown, very fine sandy, clayey silt (ML)
- 2' to 3' Yellowish brown, silty fine sand (SM)
- 3' to 5' Yellowish brown, variably cemented sand (Sandstone) (SM)
Test pit terminated at 5 feet due to rock cementation

TEST PIT 8





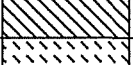
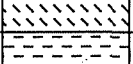

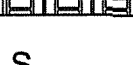
- 0 to 1½' Reddish brown, fine sandy silt (ML)
- 1½' to 6' Yellowish brown, silty fine sand with gravel to cobble sized angular weathered metavolcanic rock fragments (SM)
- 6' to 7' Greenish blue, metavolcanic rock with a yellowish brown weathering surface (Rx)
Test pit terminated at 7 feet due to refusal



UNIFIED SOIL CLASSIFICATION SYSTEM

| MAJOR DIVISIONS | SYMBOL | CODE | TYPICAL NAMES |
|---|--|---|--|
| COARSE GRAINED SOILS (More than 50% of soil > no. 200 sieve size) | GRAVELS | | |
| | GW |  | Well graded gravels or gravel - sand mixtures, little or no fines |
| | GP |  | Poorly graded gravels or gravel - sand mixtures, little or no fines |
| | GM |  | Silty gravels, gravel - sand - silt mixtures |
| | GC |  | Clayey gravels, gravel - sand - clay mixtures |
| | SANDS | | |
| | SW |  | Well graded sands or gravelly sands, little or no fines |
| | SP |  | Poorly graded sands or gravelly sands, little or no fines |
| FINE GRAINED SOILS (50% or more of soil < no. 200 sieve size) | SILTS & CLAYS | | |
| | <u>LL < 50</u> | | |
| | ML |  | Inorganic silts and very fine sands, rock flour, silty or clayey fine sands or clayey silts with slight plasticity |
| | CL |  | Inorganic clays of low to medium plasticity, gravelly clays, sandy clays, silty clays, lean clays |
| | OL |  | Organic silts and organic silty clays of low plasticity |
| | <u>LL ≥ 50</u> | | |
| SILTS & CLAYS | | | |
| MH |  | Inorganic silts, micaceous or diatomaceous fine sandy or silty soils, elastic silts | |
| CH |  | Inorganic clays of high plasticity, fat clays | |
| OH |  | Organic clays of medium to high plasticity, organic silty clays, organic silts | |
| HIGHLY ORGANIC SOILS | Pt |  | Peat and other highly organic soils |
| ROCK | RX |  | Rocks, weathered to fresh |

OTHER SYMBOLS

| | |
|---|---|
|  | = Drive Sample: 2-1/2" O.D. Modified California sampler |
|  | = Drive Sample: no recovery |
|  | = SPT Sample |
|  | = Initial Water Level |
|  | = Final Water Level |
|  | = Estimated or gradational material change line |
|  | = Observed material change line |
| <u>Laboratory Tests</u> | |
| PI = Plasticity Index | |
| EI = Expansion Index | |
| UCC = Unconfined Compression Test | |
| TR = Triaxial Compression Test | |
| GR = Gradational Analysis (Sieve) | |
| K = Permeability Test | |

GRAIN SIZE CLASSIFICATION

| CLASSIFICATION | RANGE OF GRAIN SIZES | |
|--|--|--|
| | U.S. Standard Sieve Size | Grain Size in Millimeters |
| BOULDERS | Above 12" | Above 305 |
| COBBLES | 12" to 3" | 305 to 76.2 |
| GRAVEL coarse (c) fine (f) | 3" to No. 4 3" to 3/4" 3/4" to No. 4 | 76.2 to 4.76 76.2 to 19.1 19.1 to 4.76 |
| SAND coarse (c) medium (m) fine (f) | No. 4 to No. 200 No. 4 to No. 10 No. 10 to No. 40 No. 40 to No. 200 | 4.76 to 0.074 4.76 to 2.00 2.00 to 0.420 0.420 to 0.074 |
| SILT & CLAY | Below No. 200 | Below 0.074 |



WALLACE • KUHLE & ASSOCIATES, INC.
 GEOTECHNICAL ENGINEERING
 GEOLOGIC & ENVIRONMENTAL SERVICES

UNIFIED SOIL CLASSIFICATION SYSTEM

FOLSOM HEIGHTS

Sacramento County, California

WKA NO: 6744.02

DATE: 8/05

PLATE NO: 5

APPENDIX A



**WALLACE • KUHL
& ASSOCIATES INC.**

APPENDIX A

A. GENERAL INFORMATION

The preparation of a preliminary geotechnical engineering report for the Folsom Heights Property, located south of Highway 50, on the west side of the El Dorado/Sacramento County line in eastern Sacramento County, California, was authorized on August 4, 2005 by Ms. Kim McCarley with Centex Homes, Sacramento Division. Authorization was for an investigation as described in our proposal letter of August 3, 2005, sent to our client, Centex Homes, Sacramento Division, whose mailing address is 3700 Douglas Boulevard, Suite 150, Roseville, California 95661; telephone (916) 788-9000 facsimile (916) 788-9001.

In performing this investigation we made reference to Topographic Maps provided by MacKay & Soms, dated August 8, 2005 showing the project area.

B. FIELD EXPLORATION

As indicated on Plate No. 2, eight exploratory test pits were excavated across the property on August 11, 2005, to a maximum depth of approximately 10 feet below existing site grades. The test pits were excavated with a Case 580E rubber-tired backhoe utilizing a 12-inch wide bucket.

Bulk samples of the near-surface soils were obtained for Expansion Index testing and corrosion testing. All samples were taken to our laboratory for additional soil classification and selection of samples for testing. The Logs of Test Pits, Plates No. 3 and 4, contain descriptions of the soils and rock encountered in each test pit. A legend explaining the Unified Soil Classification System used on the logs is contained on Plate No. 5.

C. LABORATORY TESTING

Two bulk samples of near-surface soil were subjected to Expansion Index testing (ASTM D4829); the result of these tests are presented on Plates No. A1 and A2.

Four near-surface soil samples was submitted to Sunland Analytical to determine the soil pH and minimum resistivity (CT 643), sulfate concentration (CT 417) and chloride concentration (CT 422). Results from these tests are presented on Plates No. A3 through A6.



EXPANSION INDEX TEST RESULTS

UBC Standard No. 29-2

ASTM D4829-88

MATERIAL DESCRIPTION: Brown, silty clay

LOCATION: TP-5

| <u>Sample Depth</u> | <u>Pre-Test Moisture (%)</u> | <u>Post-Test Moisture (%)</u> | <u>Dry Density (pcf)</u> | <u>Expansion Index *</u> |
|---------------------|------------------------------|-------------------------------|--------------------------|--------------------------|
| 0'-1' | 12.6 | 33.4 | 95.6 | 119 |

CLASSIFICATION OF EXPANSIVE SOIL **

| EXPANSION INDEX | POTENTIAL EXPANSION |
|-----------------|---------------------|
| 0 - 20 | Very Low |
| 21 - 50 | Low |
| 51 - 90 | Medium |
| 91 - 130 | High |
| Above 130 | Very High |

* Corrected to 50% Saturation

** From UBC Table 29-C



WALLACE • KUHL & ASSOCIATES, INC.
 GEOTECHNICAL ENGINEERING
 GEOLOGIC & ENVIRONMENTAL SERVICES

EXPANSION INDEX
FOLSOM HEIGHTS
 Sacramento County, California

WKA NO: 6744.02
 DATE: 8/05
 PLATE NO: A1

EXPANSION INDEX TEST RESULTS

UBC Standard No. 29-2

ASTM D4829-88

MATERIAL DESCRIPTION: Grayish brown, silty clay

LOCATION: TP-4

| <u>Sample Depth</u> | <u>Pre-Test Moisture (%)</u> | <u>Post-Test Moisture (%)</u> | <u>Dry Density (pcf)</u> | <u>Expansion Index *</u> |
|---------------------|------------------------------|-------------------------------|--------------------------|--------------------------|
| 1'-2' | 14.8 | 33.9 | 93.9 | 118 |

CLASSIFICATION OF EXPANSIVE SOIL **

| EXPANSION INDEX | POTENTIAL EXPANSION |
|-----------------|---------------------|
| 0 - 20 | Very Low |
| 21 - 50 | Low |
| 51 - 90 | Medium |
| 91 - 130 | High |
| Above 130 | Very High |

* Corrected to 50% Saturation

** From UBC Table 29-C



WALLACE • KUHL & ASSOCIATES, INC.
GEOTECHNICAL ENGINEERING
GEOLOGIC & ENVIRONMENTAL SERVICES

EXPANSION INDEX
FOLSOM HEIGHTS
Sacramento County, California

WKA NO: 6744.02
DATE: 8/05
PLATE NO: A2

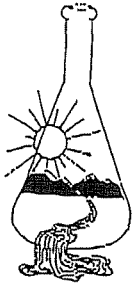

Sunland Analytical

11353 Pyrites Way, Suite 4
Rancho Cordova, CA 95670
(916) 852-8557

Date Reported 08/17/2005
Date Submitted 08/12/2005

To: David Perry
Wallace-Kuhl & Associates
3050 Industrial Blvd.
West Sacramento, CA 95691

From: Gene Oliphant, Ph.D. \ Randy Horney
General Manager \ Lab Manager *RO*

The reported analysis was requested for the following location:
Location : 6744.02/FOLSOM HEIGH Site ID : TP-4.
Your purchase order number is 9260.
Thank you for your business.

* For future reference to this analysis please use SUN # 45584-90167.

EVALUATION FOR SOIL CORROSION

| | | | |
|---------------------|----------|----------------|---|
| Soil pH | 7.25 | | |
| Minimum Resistivity | 0.86 | ohm-cm (x1000) | |
| Chloride | 12.3 ppm | 00.00123 | % |
| Sulfate | 0.4 ppm | 00.00004 | % |

METHODS

pH and Min. Resistivity CA DOT Test #643
Sulfate CA DOT Test #417, Chloride CA DOT Test #422



WALLACE • KUHL & ASSOCIATES, INC.
GEOTECHNICAL ENGINEERING
GEOLOGIC & ENVIRONMENTAL SERVICES

CORROSION TEST
FOLSOM HEIGHTS
Sacramento County, California

WKA NO: 6744.02
DATE: 8/05
PLATE NO: A3

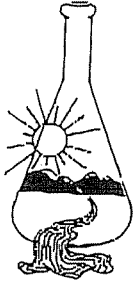

Sunland Analytical

11353 Pyrites Way, Suite 4
Rancho Cordova, CA 95670
(916) 852-8557

Date Reported 08/17/2005
Date Submitted 08/12/2005

To: David Perry
Wallace-Kuhl & Associates
3050 Industrial Blvd.
West Sacramento, CA 95691

From: Gene Oliphant, Ph.D. \ Randy Horney
General Manager \ Lab Manager *RH*

The reported analysis was requested for the following location:
Location : 6744.02/FOLSOM HEIGHTS Site ID : TP-5.
Your purchase order number is 9260.
Thank you for your business.

* For future reference to this analysis please use SUN # 45584-90168.

EVALUATION FOR SOIL CORROSION

| | | | |
|---------------------|---------|----------------|---|
| Soil pH | 6.48 | | |
| Minimum Resistivity | 1.02 | ohm-cm (x1000) | |
| Chloride | 7.8 ppm | 00.00078 | % |
| Sulfate | 0.2 ppm | 00.00002 | % |

METHODS

pH and Min. Resistivity CA DOT Test #643
Sulfate CA DOT Test #417, Chloride CA DOT Test #422



WALLACE • KUHLE & ASSOCIATES, INC.
GEOTECHNICAL ENGINEERING
GEOLOGIC & ENVIRONMENTAL SERVICES

CORROSION TEST
FOLSOM HEIGHTS
Sacramento County, California

WKA NO: 6744.02
DATE: 8/05
PLATE NO: A4

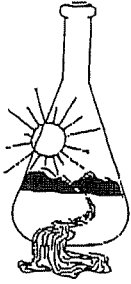

Sunland Analytical

11353 Pyrites Way, Suite 4
Rancho Cordova, CA 95670
(916) 852-8557

Date Reported 08/17/2005
Date Submitted 08/12/2005

To: David Perry
Wallace-Kuhl & Associates
3050 Industrial Blvd.
West Sacramento, CA 95691

From: Gene Oliphant, Ph.D. \ Randy Horney
General Manager \ Lab Manager

The reported analysis was requested for the following location:
Location : 6744.02/FOLSOM HEIGH Site ID : TP-7.
Your purchase order number is 9260.
Thank you for your business.

* For future reference to this analysis please use SUN # 45584-90169.

EVALUATION FOR SOIL CORROSION

| | | | |
|---------------------|---------|----------------|---|
| Soil pH | 6.79 | | |
| Minimum Resistivity | 3.48 | ohm-cm (x1000) | |
| Chloride | 4.3 ppm | 00.00043 | % |
| Sulfate | 0.1 ppm | 00.00001 | % |

METHODS

pH and Min. Resistivity CA DOT Test #643
Sulfate CA DOT Test #417, Chloride CA DOT Test #422



WALLACE • KUHL & ASSOCIATES, INC.
GEOTECHNICAL ENGINEERING
GEOLOGIC & ENVIRONMENTAL SERVICES

CORROSION TEST
FOLSOM HEIGHTS
Sacramento County, California

WKA NO: 6744.02
DATE: 8/05
PLATE NO: A5

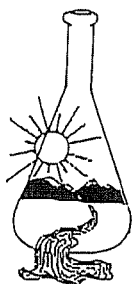

Sunland Analytical

11353 Pyrites Way, Suite 4
Rancho Cordova, CA 95670
(916) 852-8557

Date Reported 08/17/2005
Date Submitted 08/12/2005

To: David Perry
Wallace-Kuhl & Associates
3050 Industrial Blvd.
West Sacramento, CA 95691

From: Gene Oliphant, Ph.D. \ Randy Horney
General Manager \ Lab Manager

The reported analysis was requested for the following location:
Location : 6744.02/FOLSOM HEIGHTS Site ID : TP-1.
Your purchase order number is 9260.
Thank you for your business.

* For future reference to this analysis please use SUN # 45584-90166.

EVALUATION FOR SOIL CORROSION

| | | | |
|---------------------|---------|----------------|---|
| Soil pH | 6.22 | | |
| Minimum Resistivity | 2.84 | ohm-cm (x1000) | |
| Chloride | 8.4 ppm | 00.00084 | % |
| Sulfate | 0.1 ppm | 00.00001 | % |

METHODS

pH and Min. Resistivity CA DOT Test #643
Sulfate CA DOT Test #417, Chloride CA DOT Test #422



WALLACE • KUHL & ASSOCIATES, INC.
GEOTECHNICAL ENGINEERING
GEOLOGIC & ENVIRONMENTAL SERVICES

CORROSION TEST

FOLSOM HEIGHTS

Sacramento County, California

WKA NO: 6744.02

DATE: 8/05

PLATE NO: A6

APPENDIX F4

Preliminary Geotechnical Engineering Study –
White Rock Road / Scott Road 1,400 Acres

PRELIMINARY
GEOTECHNICAL ENGINEERING STUDY
for
WHITE ROCK ROAD/SCOTT ROAD
1,400 ACRES
Sacramento County
(Unincorporated) Folsom, California

Project No. E07145
May 2007

Project No. E07145.000
22 May 2007

AKT Investments, Inc.
c/o Ryan Fong with River Rock Development Company
7700 College Town Drive, Suite 250
Sacramento, California 95826-2303

Subject: **WHITE ROCK ROAD/SCOTT ROAD 1,400 ACRES**
APN 072-0060-038 & 069; 072-0270-138; 072-0070-032 & 21
Sacramento County, California
PRELIMINARY GEOTECHNICAL ENGINEERING STUDY

- Reference:
1. Proposal and Contract for White Rock Road/Scott Road 1400 Preliminary Geotechnical Engineering Study, prepared by Youngdahl Consulting Group, Inc., dated 1 June 2005.
 2. Phase I Site Assessment for Russell Ranch South, prepared by Youngdahl Consulting Group, Inc., dated April 2007 (Project No. E95027.001).
 3. Phase I Site Assessment for Mangini Property, prepared by Youngdahl Consulting Group, Inc., dated March 2007 (Project No. E07077.000).
 4. Folsom SOI - NOA Overview, Geologic Overview and Summary of NOA Potential, prepared by Youngdahl Consulting Group, Inc., dated February 2007 (Project No. E07006.000).

Dear Mr. Fong:

In accordance with your authorization, Youngdahl Consulting Group, Inc. has performed a preliminary geotechnical engineering study for the project site located on the north side of White Rock Road extending from the El Dorado County Line, to Highway 50 and westerly approximately 2.6 miles in the unincorporated Folsom area of Sacramento County, California. The purpose of this study was to explore and evaluate the general surface and subsurface soil conditions at the site and to develop preliminary geotechnical information for the proposed project. Our scope was limited to a subsurface investigation and preparation of this report, which was written for the purpose of providing general geologic and soil information for initial planning phases of the project.

Based upon our field study, subsurface exploration program, and engineering analysis, we believe the primary geotechnical issues to be addressed consist of shallow bedrock conditions as well as their associated drainage issues and rippability. Other geotechnical issues may become more apparent during mass grading operations which are not listed above. The descriptions, findings, conclusions and recommendations provided in this report are formulated as a whole, and specific conclusions or recommendations should not be derived or used out of context. Please review the limitations and uniformity of conditions section of this report.

This report has been prepared for the exclusive use of AKT Investments, Inc. and their consultants, for specific application to this project, in accordance with generally accepted geotechnical engineering practice. Should you have any questions or require additional information, please contact our office at your convenience.

Very truly yours,
Youngdahl Consulting Group, Inc.

Reviewed by:

Victor P. Dumlao, P.E.
Project Engineer

John C. Youngdahl, P.E.
Principal Engineer

Roy C. Kroll, C.E.G.
Associate Engineering Geologist

Distribution: (4) to Client

TABLE OF CONTENTS

| | | |
|-----|---|----|
| 1.0 | INTRODUCTION..... | 1 |
| | Purpose and Scope..... | 1 |
| 2.0 | PROJECT UNDERSTANDING | 1 |
| | Background | 1 |
| 3.0 | GEOLOGIC FINDINGS | 1 |
| | Surface Observations..... | 2 |
| | Subsurface Conditions | 2 |
| | Groundwater Conditions | 2 |
| | Flooding Potential | 2 |
| | Soil Expansion Potential | 2 |
| | Geologic Setting..... | 3 |
| | Naturally Occurring Asbestos (NOA) | 4 |
| | Mining & Mineral Resources | 4 |
| | Seismicity | 4 |
| | Liquefaction Potential..... | 4 |
| 4.0 | GEOTECHNICAL CONSIDERATIONS | 4 |
| | General | 4 |
| | Soil (SCS/NRCS) | 5 |
| | Soils/Rock | 5 |
| | Excavation Characteristics | 6 |
| | Engineered Fills | 6 |
| | Erosion Potential | 6 |
| | Mine Tailings | 6 |
| | Site Drainage Controls/Subdrainage..... | 7 |
| | Low Impact Development Standards | 7 |
| | Underground Improvements | 7 |
| | Liquefaction Potential..... | 7 |
| | Slope Stability | 7 |
| | Slope Configuration and Grading..... | 8 |
| | Foundations & Building Design | 8 |
| | Differential Support Conditions | 8 |
| | Faulting & Seismic Criteria | 8 |
| | Laboratory Testing | 8 |
| 5.0 | LIMITATIONS AND UNIFORMITY OF CONDITIONS | 9 |
| | CHECKLIST OF GEOTECHNICAL HAZARDS AND POTENTIAL MITIGATION MEASURES.. | 11 |
| | Additional Geological References..... | 12 |
| | APPENDIX A | 13 |
| | Field study..... | 14 |
| | Vicinity Map (Figure A-1)..... | 15 |
| | Site Map (Figure A-2)..... | 16 |
| | Logs of Exploratory Pits (Figures A-3 through A-33) | 17 |
| | Soil Classification Chart and Pit Log Legend (Figure A-34) | 58 |
| | Soils Map (NRCS) (Figure A-35)..... | 59 |
| | Geology Map (Figure A-36)..... | 60 |

PRELIMINARY GEOTECHNICAL ENGINEERING STUDY
for
WHITE ROCK ROAD AND SCOTT ROAD 1,400 ACRES

1.0 INTRODUCTION

This report presents the results of our Preliminary Geotechnical Engineering Study performed for the proposed planned community to be constructed north of White Rock Road in the unincorporated area of Folsom in Sacramento County, California. Refer to Figure A-1 and A-2 for a vicinity map for the project site. To achieve the objective of addressing the geologic and geotechnical issues for the project, Youngdahl Consulting Group, Inc. (YCG) has generally adhered to the California Environmental Quality Act (CEQA) and the California Geological Survey (CGS) Special Publication No. 46 regarding the Guidelines for Geologic/Seismic Considerations for EIR level studies.

Purpose and Scope

The purpose of this study was to explore and evaluate the surface and subsurface conditions at the site and to develop reconnaissance level geotechnical information for the proposed project. The scope of this study includes the following:

- A review of geotechnical and geologic data available to us at the time of our study.
- A reconnaissance level field study consisting of a site observation, followed by an exploratory test pit program to characterize the generalized subsurface conditions.
- Engineering analysis of the data and information obtained from our field study, aerial photography and literature review. Development of preliminary recommendations for site preparation and grading, and geotechnical concerns and conclusions.
- Preparation of this report summarizing our findings, and conclusions regarding the geotechnical aspects for the project.

2.0 PROJECT UNDERSTANDING

Based on the preliminary layout plans provided by you, the proposed construction is expected to include a planned community including subdivision development, commercial and retail shopping centers, schools, and associated infrastructure. Most structures are anticipated to generate relatively light loads with shallow foundations.

For the purposes of this report, we have assumed that grading operations will consist of cuts and fills on the order of 30 feet or less.

Background

Review of available information and aerial photos indicate that the project site was primarily used for agricultural and/or grazing lands for livestock. Some mining features as well as old foundations for small structures and other structures associated with previous mining operations were observed on the site (and described in References 2 and 3). Radio towers are constructed near the peak of the eastern parcel on the northern end.

3.0 GEOLOGIC FINDINGS

Surface Observations

The subject site is comprised of 5 irregularly shaped parcels roughly delineated by the Sacramento County Line and the El Dorado County Line on the east, Highway 50 on the north, White Rock Road on the south and undeveloped lands to the west. The combined acreage for all of the parcels is approximately 1,400 acres. Site topography includes low to medium rolling hills to the west and a larger hill to the east in excess of 200 feet of vertical relief. The terrain



features have a tendency to develop natural drainage swales and creeks. Natural drainage swales of varying sizes traverse the site collecting surface runoff and are located throughout the property. Some reservoirs are also present in the central parcels. Several radio towers are located on the hill to the northeast. Some remnants of old foundations and water structures are present on the eastern portion of the properties to the west. The properties are covered by low to moderate grass growth throughout the parcels with some rock outcrops at the surface in all parcels. Tree growth consisting primarily of varying sized oaks is limited to the western third of the western parcel (west of Scott Road).

Subsurface Conditions

Our field study included a site reconnaissance by a Youngdahl Consulting Group, Inc. representative followed by a (reconnaissance-level) subsurface exploration program conducted on 24 April through 25 April 2007, which included the excavation of 31 test pits under his direction at the approximate locations shown on Figure A-2, Appendix A. A description of the field exploration is provided in Appendix A.

Test pits generally encountered surface soils consisting predominantly of silty SANDS/sandy SILTS in a loose and moist to saturated condition to depths varying from ½ to 3 ½ feet below current site grades. Underlying the surface fills and native soils, weathered metasandstone and slate BEDROCK was encountered to the maximum depth explored in each pit. Effective refusal was encountered with the equipment used for our study. The bedrock graded moderately weathered at the bottom of each pit. A detailed seismic refraction study can provide more information regarding subsurface rock conditions and rippability.

A more detailed description of the subsurface conditions encountered is presented graphically on the "Exploratory Test Pit Logs", Figures A-3 through A-33, presented in Appendix A. These logs show a graphic interpretation of the subsurface profile, the location and depths at which samples were collected.

Groundwater Conditions

Groundwater was generally not encountered during our explorations. However, subsurface water conditions typically vary in the foothill region. Our experience in the area shows that water may be perched on less weathered rock and present in the fractures, and seams of the weathered rock found beneath the site at varying times of the year.

Flooding Potential

According to the Federal Emergency Management Agency flood zone map, the project area is incorporated into Zone X. Zone X is considered to be outside the 500 year flood zone. Flooding circumstances, outside seasonal conditions, are not expected to have a significant impact within the project area.

Soil Expansion Potential

We encountered a clay layer in Test Pit TP-5. Clay layers are typically in low lying areas and above the bedrock horizons. In concentrated amounts, such clays could cause distress to concrete slab-on-grade floors and foundations if present in the upper 3 feet of the structural improvement areas. However, given their limited presence, it has been our experience that these materials can be sufficiently blended such that expansive soil mitigation measures may not be required.

Geologic Setting

The geologic portion of this report included a review of geologic data pertinent to the site, and an interpretation of our observations and the Logs of Exploratory Test Pits excavated during the field study.



The site is located at the base of the Sierra Foothills region of the Sierra Nevada Mountain Range. According to the "Generalized Geology of the Folsom 15-Minute Quadrangle" (Lloyd, 1984) and confirmed by our subsurface exploration, the site is underlain by undifferentiated metavolcanic and metasedimentary rocks of the Gopher Ridge Volcanics (Jgo), Copper Hill Volcanics (Jch), and Salt Springs (Jss) formations formed during the Jurassic Period (Figure A-36). The Copper Hill Volcanics in the project area are found east of Old Placerville Road on the Russell Ranch South portion. Also included is a relatively small intrusion of gabbro (gb) associated with the Foothills Melange-Ophiolite Terrane, also Jurassic in age. A Tertiary-aged alluvial unit consisting of sands, silts, and conglomerates, the Laguna Formation (TI), is present at the southwest corner of the project site. The metavolcanic bedrock is characterized by a greenish gray color on a fresh surface, weathering to yellowish brown, and typically without foliation. The metasedimentary bedrock is typically found in the form of gray to black, well foliated "slate", or brown sandstone, typically without foliation. The gabbro is nearly black on a fresh surface, but easily weathers to orangish brown and even very light gray to white. It is very granular and typically not foliated. All of the noted bedrock types are usually observed to contain various degrees of fracturing and weathering. The degree of weathering typically decreases with depth. Foliations, where present, and lenticular rock bodies, had a northwesterly trend and steep dip to the east.

Naturally Occurring Asbestos (NOA)

The Sacramento Metropolitan Air Quality Management District (SMAQMD) is the lead agency for regulating NOA in Sacramento County. When NOA was discovered at the Lago Vista School site in Folsom in 2004, they immediately implemented the construction Air Toxic Control Measure (ATCM) (CCR Section 93015) for projects in East Folsom within the metavolcanic Copper Hill Formation. SMAQMD staff also received a request from the Sacramento County Department of Environmental Review regarding the inclusion of an assessment for NOA in the Environmental Impact Report (EIR) process for projects in the eastern part of Sacramento County. They initiated discussions with the California Geological Survey at this point. In 2005, the SMAQMD expanded the NOA area to include all areas underlain by the Copper Hill Formation, as well as the Gopher Ridge Formation, also metavolcanic. In July of 2006, after CGS released the generalized geologic map of eastern Sacramento County, the SMAQMD established a policy of applying the construction ATCM (CCR Section 93105) to all areas identified as being underlain by rocks moderately likely to contain NOA.

The air quality management districts in California have the responsibility for implementing and enforcing the construction ATCM. In practice, the California Air Resources Board (ARB) allows each air quality management district some latitude on how they interpret the ATCM. The construction ATCM provides a mechanism by which to remove properties from the requirements of the ATCM through a geologic evaluation. The SMAQMD interprets the ATCM to apply to a "real property" (verbal communications with SMAQMD staff). This means that no matter how large the property, if one instance of NOA (above regulatory thresholds) is found on a legal parcel, then they require that the ATCM would apply to the entire parcel.

The relative likelihood for the presence of NOA is least for the Salt Springs Slate, yet moderately likely for the Copper Hills, Gopher Ridge, and gabbro units. The low-grade, greenschist facies, regional metamorphism, with hydrothermal alteration is characteristic of NOA containing rocks of this region. NOA, if present will be visible within the bedrock at depth during trenching activities. NOA typically weathers to clays at near surface depths and therefore, is generally not visible (Reference 4).

A detailed assessment of site NOA conditions can be conducted as necessary as each phase of development within the limits of these properties is started (as detailed in Reference 4).



Mining & Mineral Resources

According to the Mineral Land Classification of the Folsom 15-Minute Quadrangle (Loyd, 1984) two lode gold mines, both called Mangini Ranch, are situated in the quartz veins within the Gopher Ridge Volcanics. These mines have been occasionally mined between the gold rush days leading up to the 1920s. These mines consist of open shafts and exploration pits with quartz and other waste rock tailing piles (Reference 3).

Seismicity

According to the Fault Activity Map of California and Adjacent Areas (Jennings, 1994) and the Peak Acceleration from Maximum Credible Earthquakes in California (CDMG, 1992), no active faults or Earthquake Fault Zones (Special Studies Zones) are located on the project site. No evidence of recent or active faulting was observed during our field study. The nearest mapped faults to the site are related to the Bear Mountains, Melones Fault, and the Mormon Island Shear Zones (trends with the County line between El Dorado and Sacramento Counties) located from 3 to 13 kilometers east of the site. Soil stratigraphic dating indicates these faults have not moved within the past 65,000 to 70,000 years (Tierra Engineering, 1983). The nearest mapped active fault to the site is the Dunnigan Hills fault located about 65 kilometers to the west-northwest.

Based on our literature review of shear-wave velocity characteristics of geologic units in California (Wills and Silva; August 1998; Earthquake Spectra, Volume 14, No. 3) and subsurface interpretations, we recommend that the project be designed in accordance with the 2001 California Building Code (CBC), Chapter 16. This site is located within Seismic Risk Zone 3 and based on our subsurface interpretations and literature review is classified as Soil Profile Type S_B.

Liquefaction Potential

Liquefaction is the sudden loss of soil shear strength and sudden increase in porewater pressure caused by shear strains, as could result from an earthquake. Research has shown that saturated, loose to medium-dense sands with a silt content less than about 25 percent located within the top 40 feet are most susceptible to liquefaction. Due to the absence of a permanent elevated groundwater table, the relatively low seismicity of the area, the relatively shallow depth to bedrock, and the relatively dense nature of site materials, the potential for site liquefaction is considered negligible.

4.0 GEOTECHNICAL CONSIDERATIONS

General

Based upon the results of our field explorations and analysis, it is our opinion that construction of the proposed improvements is feasible from a geotechnical standpoint. The native soils, rock, and/or engineered fills composed of like materials and processed and compacted as engineered fills are considered suitable for support of the onsite improvements. Development and grading of the parcels would include some geotechnical concerns with the subsurface soils, bedrock and terrain. The presence of hard rock can cause excavation difficulty as well as create an impermeable layer causing perched water conditions. Natural drainage swales that are present throughout the property, that will be lost in development, may require subsurface drainage controls. Because this report provides preliminary general recommendations for a large site, we recommend that laboratory testing and site specific geotechnical studies to be coordinated for each phase build out. The following paragraphs state additional geotechnical comments.



Soil (SCS/NRCS)

According to the USDA Soil Conservation Service Soil Survey of Sacramento County, California (1993), the soils at the subject property consist of Argonaut-Auburn complex, 3 to 8 percent slopes, HSG D (Map Unit 107), Auburn silt loam, 2 to 30 percent slopes, HSG D (Map Unit 109) and Auburn-Argonaut-Rock outcrop complex, 8 to 30 percent slopes, HSG D (Map Unit 110) and Whiterock loam, 3 to 30 percent slopes, HSG D (Map Unit 237). Argonaut-Auburn complex contains 45 percent Argonaut soils and 35 percent Auburn soils. The Argonaut soils is moderately deep and well drained and formed from material weathered from metamorphosed volcanic rock. Permeability is slow and water is perched above the claypan for short periods after heavy storms in winter and early spring. Available water capacity is low and depth to bedrock is 20 to 40 inches. Runoff potential is medium. The Auburn soil is shallow or moderately deep and well drained and forms from weathered metabasic and metasedimentary rocks. Permeability is moderate and water capacity is low to very low. Depth to bedrock is 10 to 28 inches. Runoff potential for this soil is medium. The Whiterock loam is very shallow and excessively well drained. It is formed from vertically tilted weathered metasedimentary bedrock. Included in this unit are small areas of Argonaut and Auburn soils and Rock outcrop. Depth to bedrock is 4 to 14 inches. Permeability is moderate and available water capacity is very low. Runoff potential for this soil is medium to rapid. The project area soils have a moderate to high corrosion potential.

Soils/Rock

Site development and mass grading/grading operations will likely include rocky fills. Projects developed in the vicinity have typically included balance cuts and fills comprised of native soils and rock. In areas where deep cuts are proposed and surface soils are shallow above the bedrock layer, sufficient fines to be mixed with rocky fills may be short and may require additional breakdown of rockier materials by crushing and/or heavy equipment kneading, or import of soils to prevent nesting of larger boulders and air voids where these cut soils are used for fills. Blasting has also been used in locations where deep, hard rock excavations were needed.

Excavation Characteristics

The test pits were excavated using a John Deere 310SG backhoe equipped with a 24 inch wide bucket. The degree of difficulty encountered in excavating our test pits is an indication of the effort that will be required for excavation during construction. Based on our test pits, we expect that the site soils can be excavated using conventional earthmoving equipment; however, as stated above, a seismic refraction study can detail a closer approximation of the excavation equipment requirements and effort needed in most of the deeper cuts.

The underlying rock materials can likely be excavated to depths of several feet using dozers equipped with rippers. We expect that the upper, weathered portion of the rock, indicated to extend 10 feet below the rock surface at most locations, will require use of at least a Caterpillar D8 equipped with a single or multiple shank rippers, or similar equipment. We anticipate that a ripper equipped D8 can penetrate at least as deep as our test pits at most locations with moderate effort. Deeper excavation into the less weathered rock may require heavier equipment, such as a D9, or a D10. Blasting cannot be ruled out in areas of resistant rock.

Where hard rock cuts in fractured rock are proposed, the orientation and direction of ripping will likely play a large role in the rippability of the material. Seismic refraction geophysical lines should be considered for planned areas of deep cut or existing prominent rock outcrops. When hard rock is encountered, we should be contacted to provide additional recommendations prior to performing an alternative such as blasting.



Utility trenches will likely encounter hard rock excavation conditions especially in deeper cut areas. Utility contractors should be prepared to use special rock trenching equipment such as large excavators (CAT 235 or CAT 245 or equivalent). Blasting to achieve utility line grades, especially in planned cut areas, cannot be precluded. Water inflow into any excavation approaching hard rock surface is likely to be experienced in all but the driest summer and fall months. Pre-ripping during mass grading may be beneficial and should be considered with the Geotechnical Engineer prior to, or during mass grading.

Engineered Fills

Suitability of On-Site Materials: We anticipate that a large amount of on-site soils will be generated during mass grading operations. We expect that soil generated from excavations on the site, excluding deleterious material, may be used as engineered fill.

Compaction Equipment: In areas to receive structural fill, a Caterpillar 825 steel-wheel compactor, large vibratory padded drum compactor, or approved equivalent will likely need to be employed as a minimum to facilitate breakdown of oversize bedrock materials and generation of soil fines during the fill placement process.

Erosion Potential

The National Resources Conservation Services (NRCS) USDA soil survey of Sacramento County (1991) classifies the Argonaut-Auburn Complex soil (mapped as unit "107") to have a slight erosion with a medium surface runoff potential. The Auburn Silt Loam, Auburn-Argonaut-Rock complex, and Whiterock Loam soils (mapped as units "109," "110," "237" respectively) have a slight to moderate erosion potential with a medium to rapid surface runoff potential.

Mine Tailings

Minor tailing piles are present at the project area with other historic mining features. They consist mostly of quartz and other rock from the shallow hard rock mining of quartz veins for gold (Reference 3). These piles are too small to be mapped in the Soil Survey of Sacramento County (1991). Larger tailing piles features are present west of the site and are visible in aerial photographs. Mine tailings may be subject to burial in designated deeper fill areas, depending upon development layouts.

Site Drainage Controls/Subdrainage

Initial site preparation may involve intercepting and diverting any potential sources of surface or near-surface water within the construction zones that may follow shallow impermeable bedrock zones and water seeping from fractures in cut bedrock. Natural springs cannot be precluded and may require mitigation measures to control water. Due to the underlying rock predominate across the site, engineering design should recognize the fact that a shallow perched water condition is present and should be appropriately mitigated or anticipated in the design.

Because the selection of an appropriate drainage system will depend on the water quantity, season, weather conditions, construction sequence, and contractor's methods, final decisions regarding drainage systems are best made in the field at the time of construction. All drainage and/or water diversion performed for the site should be in accordance with the Clean Water Act and Storm Water Pollution Prevention Plan that will be developed for the improvements.

Swales and natural hillside drainage proposed to receive engineered fill may require the installation of a canyon style drain. Close coordination between the design professionals for placement and discharge of canyon style drains should be performed.



Low Impact Development Standards

Low Impact Development or LIDs standards have become a consideration for many projects in the region. LID standards are intended to address and mitigate urban storm water quality concerns. These methods include the use of Source Controls, Run-off Reduction and Treatment Controls. For the purpose of this report use of proposed Run-off Reduction measures and some Treatment Controls may impact geotechnical recommendations for the project. Use of any Run-off Reduction Measure or infiltration type Treatment Control should be reviewed by Youngdahl Consulting Group, Inc. during the design process.

A review of soil survey and the data collected from test pits indicate that soils within the project are Hydrologic Soil Group D (low permeability) with a depth of less than 3 feet. Based on this condition use of infiltration type LID methods (infiltration trenches, dry wells, infiltration basins, etc..) should not be considered for this property. Youngdahl Consulting Group, Inc. did not perform any percolation or infiltration testing for the site as part of the Geotechnical Investigation.

Underground Improvements

Underground construction for site infrastructure would likely encounter hard rock excavation in all but the shallowest excavations. Due to the impermeable nature of the backfills used in underground improvements, water collection in these backfill materials should be anticipated and drainage measures may be necessary.

Liquefaction Potential

Based on our reconnaissance level subsurface exploration and site observations, the dense nature Due to the absence of a permanent elevated groundwater table, the relatively low seismicity of the area, the relatively shallow depth to bedrock, and the relatively dense nature of site materials, the potential for site liquefaction is considered negligible.

Slope Stability

The existing slopes on the project site were observed to have adequate vegetation on the slope face, appropriate drainage away from the slope face, and no apparent tension cracks or slump blocks in the slope face or at the head of the slope. According to Loyd (1984), the major geologic structural framework of the region consists of northwest trending units that had undergone low-grade metamorphism on a regional scale. The bedding, foliation features, other major structural features such as faults and shear zones, and local quartz veins trend in a northwest pattern and steeply dip to the east. The Gopher Ridge and Copper Hill Volcanics are highly fractured and jointed where 2:1 cut-slopes typically have wedge pop-outs.

Slope Configuration and Grading

Generally a cut slope orientation of 2H:1V is considered stable with the material types encountered on the site. A fill slope constructed at the same orientation is considered stable if compacted to the engineered fill recommendations as stated in the recommendations section of this report. All slopes should have appropriate drainage and vegetation measures to minimize erosion of slope soils.

Steeper fill slope gradients may be achievable by approval from the project geologist or through the use of geotextile materials to strengthen and/or provide erosion protection. Surficial stability of steeper cut slopes may be achievable due to the geology of the cut materials. Steepening of slopes greater than 2H:1V will require design and observation during the proposed cut and/or fill. Any slope excavations proposed to be greater than 10 feet in maximum height should be evaluated during and prior to completion of site grading.



Slope Drainage: Surface drainage should not be allowed to flow uncontrolled over any slope face. Adequate surface drainage control should be designed by the project civil engineer in accordance with the latest applicable edition of the California Building Code (CBC). All slopes should have appropriate drainage and vegetation measures to minimize erosion of slope soils.

Foundations & Building Design

In our opinion, isolated or continuous shallow spread footings will provide adequate support for most structures.

Based on the most current CBC, soils present as evident in our cursory subsurface exploration, range from Soil Type 2 to 4 (CBC Table 18-I-A, Allowable Foundation and Lateral Pressure), which have allowable foundations pressures (psf) ranging from 1,500 to 2,000. Associated values for lateral pressures and coefficients of friction can range from 150 to 400 (psf) and 0.25 to 0.35, respectively. Laboratory specific testing will likely yield higher values.

Differential Support Conditions

The shallow bedrock conditions can pose a risk when constructing building pads on a hillside when a portion of the pad is in built into cut and the other portion is built into engineered fills. The potential for structures to differentially settle because of these circumstances can be diminished by recognition of the condition and proper engineering design. Methods employed to address this typically have included stiffening foundations with additional reinforcing steel and/or deepening foundations.

Faulting & Seismic Criteria

Based on the latest applicable edition of the California Building Code, Chapter 16, Division IV, and our site investigation findings, the following seismic parameters are recommended from a geotechnical perspective for structural design. The final choice of design parameters, however, remains the purview of the project structural engineer.

| CBC - CHAP. 16 TABLE NO. | SEISMIC PARAMETER | RECOMMENDED VALUE |
|-----------------------------|--|-------------------|
| 16-I | Seismic Zone Factor Z | 0.30 |
| 16-J | Soil Profile Type | S _B |
| 16-Q | Seismic Coefficient (C _s) | 0.30 |
| 16-R | Seismic Coefficient (C _v) | 0.30 |
| 16-S,-T | Near Source Factors (N _s , N _v) | 1.0 |
| 16-U | Seismic Source Type | C |

Laboratory Testing

Laboratory testing was not conducted for this level of discussion. Site specific testing to develop geotechnical conclusions and recommendations can be conducted for design parameters for pavement designs, retaining walls, and foundations when each phase of development is approved at the specific-plan level and subject to detailed engineering design.



5.0
1.

LIMITATIONS AND UNIFORMITY OF CONDITIONS

This report has been prepared for the exclusive use of AKT Investments, Inc. for specific application to the White Rock Road and Scott Road 1,400 Acre project. Youngdahl Consulting Group, Inc. has endeavored to comply with generally accepted geotechnical engineering practice common to the local area. Youngdahl Consulting Group, Inc. makes no other warranty, express or implied.

2. As of the present date, the findings of this report are valid for the property studied. With the passage of time, changes in the conditions of a property can occur whether they be due to natural processes or to the works of man on this or adjacent properties. Legislation or the broadening of knowledge may result in changes in applicable standards. Changes outside of our control may cause this report to be invalid, wholly or partially. Therefore, this report should not be relied upon after a period of three years without our review nor should it be used or is it applicable for any properties other than those studied.

3. Section 3317.8 in Appendix Chapter 33 of the latest edition of the California Building Code is applicable to this report. This section states that, in regard to the transfer of responsibility, if the Geotechnical Engineer of Record for the project site is not maintained into and through the grading phase of the project, the work shall be stopped until the replacement has agreed in writing to accept their responsibility within the area of technical competence for approval upon completion of the work.

WARNING: Do not apply any of this report's conclusions or recommendations if the nature, design, or location of the facilities is changed. If changes are contemplated, Youngdahl Consulting Group, Inc. must review them to assess their impact on this report's applicability. Also note that Youngdahl Consulting Group, Inc. is not responsible for any claims, damages, or liability associated with any other party's interpretation of this report's subsurface data or reuse of this report's subsurface data or engineering analyses without the express written authorization of Youngdahl Consulting Group, Inc.

4. The analyses and recommendations contained in this report are based on limited windows into the subsurface conditions and data obtained from subsurface exploration. The methods used indicate subsurface conditions only at the specific locations where samples were obtained, only at the time they were obtained, and only to the depths penetrated. Samples cannot be relied on to accurately reflect the strata variations that usually exist between sampling locations. Should any variations or undesirable conditions be encountered during the development of the site, Youngdahl Consulting Group, Inc., will provide supplemental recommendations as dictated by the field conditions.

5. The recommendations included in this report have been based in part on assumptions about strata variations that may be tested only during earthwork. Accordingly, these recommendations should not be applied in the field unless Youngdahl Consulting Group, Inc. is retained to perform construction observation and thereby provide a complete professional geotechnical engineering service through the observational method. Youngdahl Consulting Group, Inc. cannot assume responsibility or liability for the adequacy of its recommendations when they are used in the field without Youngdahl Consulting Group, Inc. being retained to observe construction. Unforeseen subsurface conditions containing soft native soils, loose or previously placed non-engineered fills should be a consideration while preparing for the grading of the property. It should be noted that it is the responsibility of the owner or his/her representative to notify



Youngdahl Consulting Group, Inc., in writing, a minimum of 48 hours before any excavations commence at the site.

- 6 Our experience has shown that vapor transmission through concrete is controlled through proper concrete mix design. As such, proper control of moisture vapor transmission should be considered in the design of the slab as provided by the project architect, structural or civil engineer. It should be noted that placement of the recommended plastic membrane, proper mix design, and proper slab underlayment and detailing per ASTM E1643 and E1745 will not provide a waterproof condition. If a waterproof condition is desired, we recommend that a waterproofing expert be consulted for slab design.
- 7 Following site development, additional water sources (ie. landscape watering, downspouts) are generally present. The presence of low permeability materials can prohibit rapid dispersion of surface and subsurface water drainage. Utility trenches typically provide a conduit for water distribution. Provisions may be necessary to mitigate adverse effects of perched water conditions. Mitigation measures may include the construction of cut-off systems and/or plug and drain systems. Close coordination between the design professionals regarding drainage and subdrainage conditions may be warranted.

Seepage may be observed emanating from the cut slopes following their excavation during the following rainy season or following development of the areas above the cut. Generally this seepage is not enough flow to be a stability issue to the cut slope, but may be an issue for the owner of the lot at the base of the cut from a surface drainage and standing water (damp spot) standpoint. This amount of water is generally collected easily with landscaping drainage, surface drainage at the toe of the slope, or subsurface toe drains. Recommendations may be provided at the time of observed seepage; however, we recommend that the developer of the property disclose this possibility to future owners.



CHECKLIST OF GEOTECHNICAL HAZARDS AND POTENTIAL MITIGATION MEASURES
(MODIFIED FROM CGS NOTE 46)

| Geologic Problems | Problem | Activity Causing Problem | Degree of Hazard or Problem | | | | Possible Mitigation Measure | | |
|-------------------------------------|---------|--|-----------------------------|--------|----------|--------|-----------------------------|---------------------------------|--|
| | | | None | Slight | Moderate | Severe | Code Conformance | Code Conformance + Special Work | Advanced Planning, Avoidance, Restrictions |
| Earthquake Damage | | Fault Movement (onsite) | X | | | | | | |
| | | Liquefaction | X | | | | | | |
| | | Landslides | X | | | | | | |
| | | Differential Compaction / Seismic Settlement | X | | | | | | |
| | | Ground Rupture | X | | | | | | |
| | | Ground Shaking | X | | | | | | |
| | | Tsunami | X | | | | | | |
| | | Seiches | X | | | | | | |
| Loss of Mineral Resources | | Flooding (Dam or Levee Failure) | X | | | | | | |
| | | Loss of Access | X | | | | | | |
| | | Deposits Covered by Changed Land Use | X | | | | | | |
| Waste Disposal Problems | | Zoning Restrictions | X | | | | | | |
| | | Change in Groundwater Level | X | | | | | | |
| | | Disposal of Excavated Material | | | X | | X | | |
| Slope and/or Foundation Instability | | Percolation of Waste Material | | | X | | X | | |
| | | Landslides and Mudflows | | X | | | | | |
| | | Unstable Cut and Fill Slopes | | | X | | X | | |
| | | Collapsible and Expansive Soil | | | X | | | X | |
| Erosion, Sedimentation, Flooding | | Trench-Wall Stability | | | X | | | X | |
| | | Erosion of Graded Areas | | | X | | X | | |
| | | Alteration of Runoff | | | X | | X | | |
| | | Unprotected Drainage Ways | | | X | | X | | |
| Land Subsidence | | Increased Impervious Surfaces | | | X | | X | | |
| | | Extraction of Groundwater, Gas, Oil, Geothermal Energy | | X | | | | | |
| Volcanic Hazards | | Hydrocompaction, Peat Oxidation | | X | | | | | |
| | | Lava Flow | | X | | | | | |
| | | Ash Fall | | X | | | | | |

* "Special Work" can include additional investigation, special site preparation, or special foundations.

ADDITIONAL GEOLOGICAL REFERENCES

- **Boore, D.M., Joyner, W.B., and Fumal, T.E., (1994):** "Estimation of Response Spectra and Peak Accelerations From Western North American Earthquakes: An Interim Report, Part 2", U.S. Geological Survey, Open-File Report 94-127.
- **Jennings, C.W., (1994):** "Fault Activity Map of California and Adjacent Areas", California Department of Conservation, Division of Mines and Geology, Geologic Data Map No. 6, Scale 1:750,000; Accompanying Text 92 pages.
- **Loyd, R.C., (1984):** "Mineral Land Classification of the Folsom 15-Minute Quadrangle, Sacramento, El Dorado, Placer, and Amador Counties, California", California Department of Conservation, Division of Mines and Geology, Open-File Report 84-50.
- **FEMA Website:** (Date Accessed 5/22/07) Federal Emergency Management Agency <http://msc.fema.gov/webapp/wcs/stores/servlet/FemaWelcomeView?storeId=10001&catalogId=10001&langId=-1> Map Nos.: 0602620150B, 0602620120D, 0602620250C, 0602620275D
- **NRCS Website:** (Date Accessed 5/22/07) National Resources Conservation Service (NRCS) <http://websoilsurvey.nrcs.usda.gov/app/WebSoilSurvey.aspx>
- **Tierra Engineering Consultants, Inc., (1983):** Geologic and Seismologic Investigations of the Folsom California Area, Final Report, Prepared For U.S. Army Engineer District - Sacramento, Contract No. DACW05-82-C-0042, Dated July 1983.
- **U.S. Department of Agriculture (USDA) Soil Conservation Service:** "Soil Survey of Sacramento County, California," (Preliminary Draft, issued June 1991).
- **Wagner, D.L., and others, (1981):** "Geologic Map of the Sacramento Quadrangle - Map No. 1A (Geology), Regional Geologic Map Series, 4 Sheets, California Department of Conservation, Division of Mines and Geology, Scale 1:250,000.

APPENDIX A

Field Study

Vicinity Map

Site Plan

Logs of Exploratory Test Pits

Soil Classification Chart and Log Exploration

Soils Map (NRCS)

Geology Map



Introduction

The contents of this appendix shall be integrated with the preliminary geotechnical engineering study of which it is a part. They shall not be used in whole or in part as a sole source for information or recommendations regarding the subject site.

Field study

Our field study included a site reconnaissance by a Youngdahl Consulting Group, Inc. representative followed by a subsurface exploration program conducted on 24 April through 25 April 2007, which included the excavation of 31 test pits under his direction at the approximate locations shown on Figure A-2, this Appendix. Excavation of the test pits was accomplished with a John Deere 310SG rubber tire-mounted backhoe equipped with a 24 inch wide bucket.

The Exploratory Test Pit Logs describe the vertical sequence of soils and materials encountered in each test pit, based primarily on our field classifications and supported by our subsequent laboratory examination and testing. Where a soil contact was observed to be gradual, our logs indicate the average contact depth. Our logs also graphically indicate the sample type, sample number and approximate depth of each soil sample obtained from the test pits.

The soils encountered were logged during excavation and provide the basis for the "Logs of Test Pits", Figures A-3 through A-33, this Appendix. These logs show a graphic representation of the soil profile, the location and depths at which samples were collected.

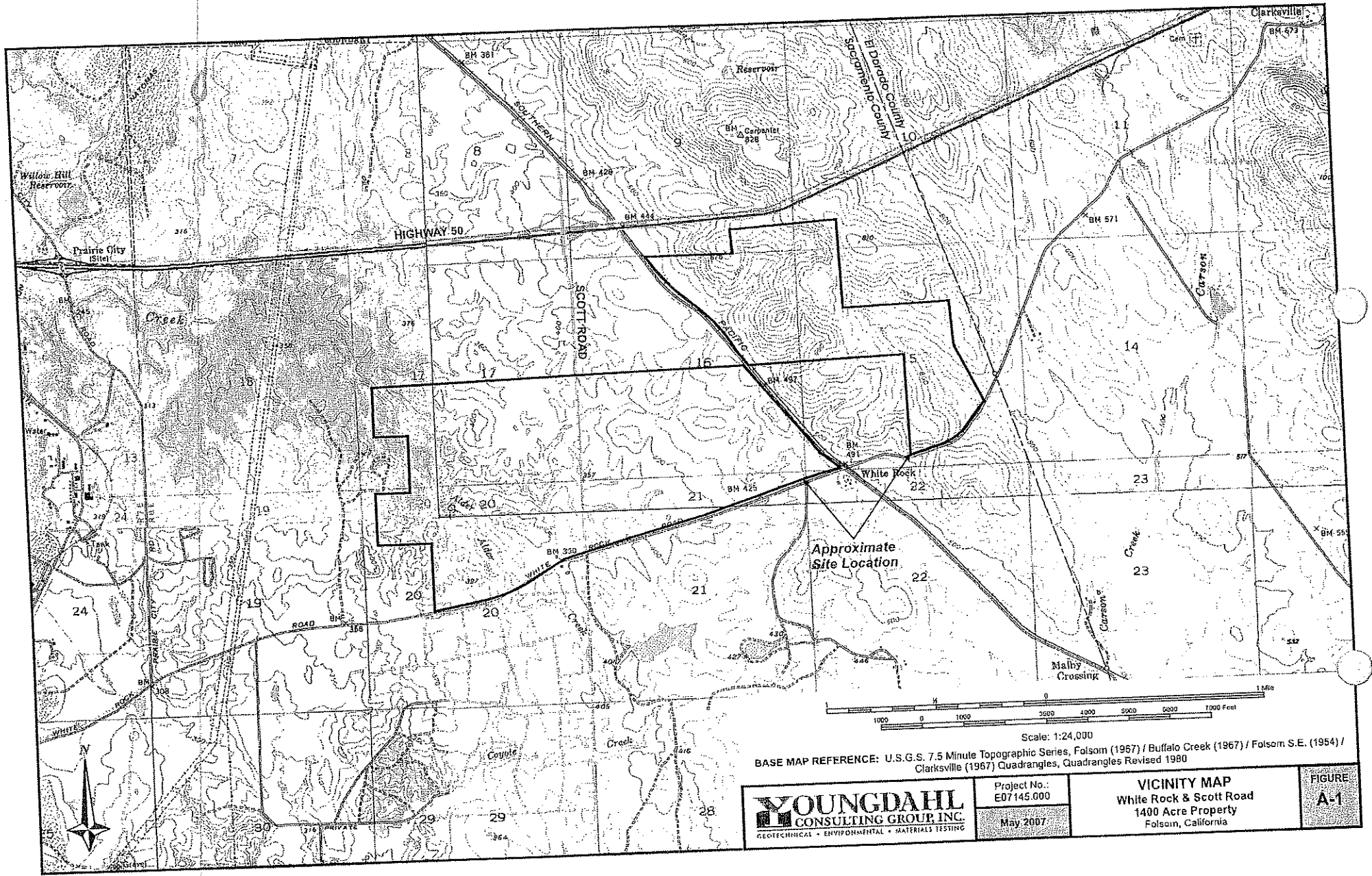

Scale: 1:24,000
 BASE MAP REFERENCE: U.S.G.S. 7.5 Minute Topographic Series, Folsom (1967) / Buffalo Creek (1967) / Folsom S.E. (1954) / Clarksville (1967) Quadrangles, Quadrangles Revised 1980

YOUNGDAHL
 CONSULTING GROUP INC.
 GEOTECHNICAL • ENVIRONMENTAL • MATERIALS TESTING

Project No.:
 E07145.000
 May 2007

VICINITY MAP
 White Rock & Scott Road
 1400 Acre Property
 Folsom, California

FIGURE
A-1

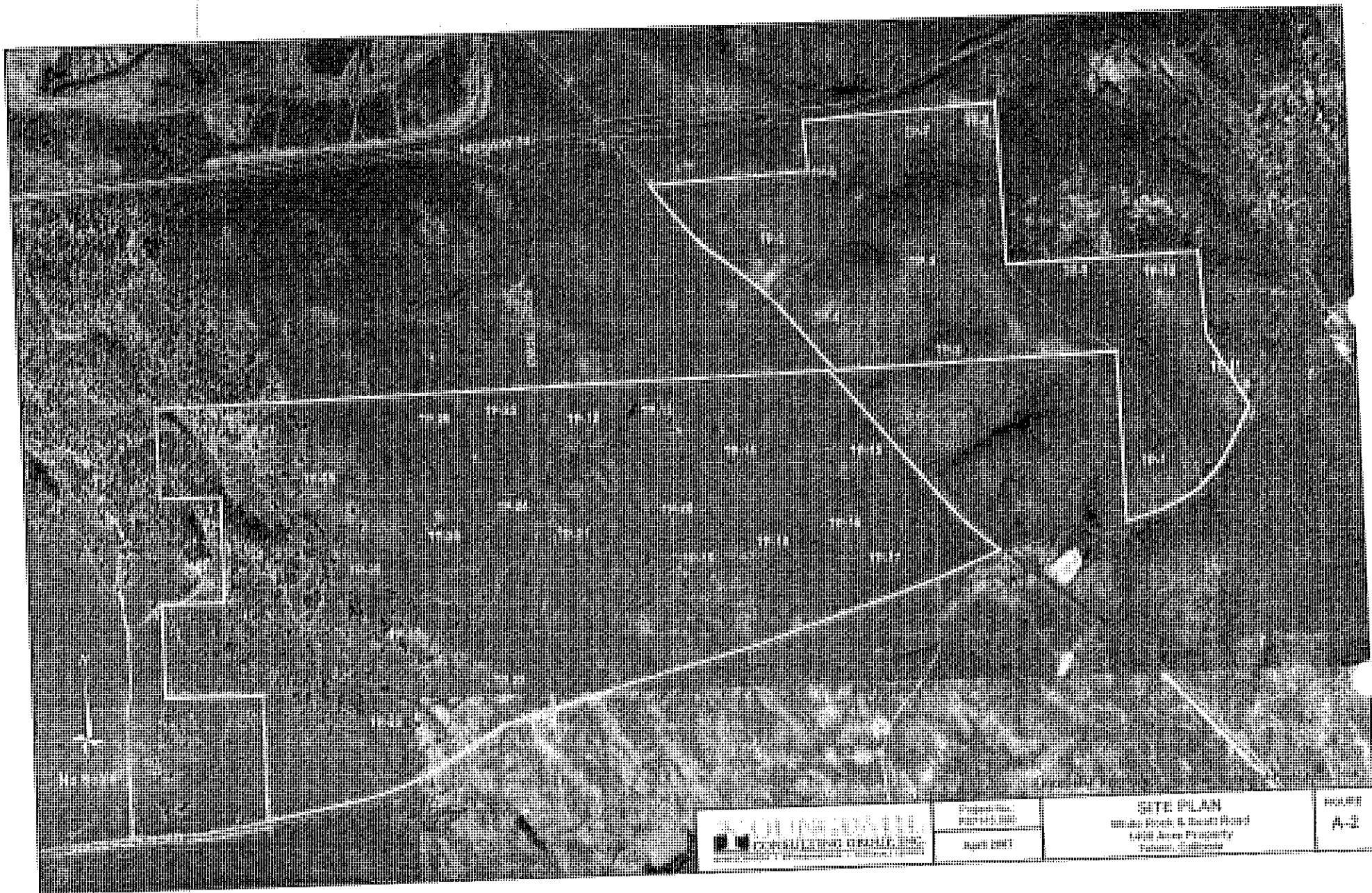

ENVIRONMENTAL RESOURCES, INC.
 10000 W. 10th Avenue, Suite 100
 Denver, Colorado 80202
 Phone: (303) 751-1100
 Fax: (303) 751-1101

Project No.:
 04-001-000
 Report Date:

SITE PLAN
 Main Book & Sheet Board
 14000 Avenue Property
 Federal, Colorado

Project
A-2

| | | | |
|---|----------------------------|-------------------------------|------------------------|
| Logged By: KEM | Date: 24 April 2007 | Elevation: | Pit No. TP-1 |
| Equipment: John Deere SG with 24" Bucket | | Pit Orientation: N - S | |

| Depth (Feet) | Geotechnical Description & Unified Soil Classification | Sample | Tests & Comments |
|---------------|--|--------|------------------|
| @ 0 - 0.5' | Red brown silty SAND (SM) with trace gravel, loose, slightly moist, with small roots | | NOA: 0' - 7.5' |
| @ 0.5' - 5.5' | Yellow brown metasandstone BEDROCK , completely weathered, weakly indurated, well developed fracturing, fractures closed with black staining to open at 1/2" with soil filling, moist | | |
| @ 5.5' - 7.5' | Grades gray brown, highly weathered, moderately indurated | | |
| | Test pit terminated at 7.5' (practical refusal) No free groundwater encountered No caving noted | | |

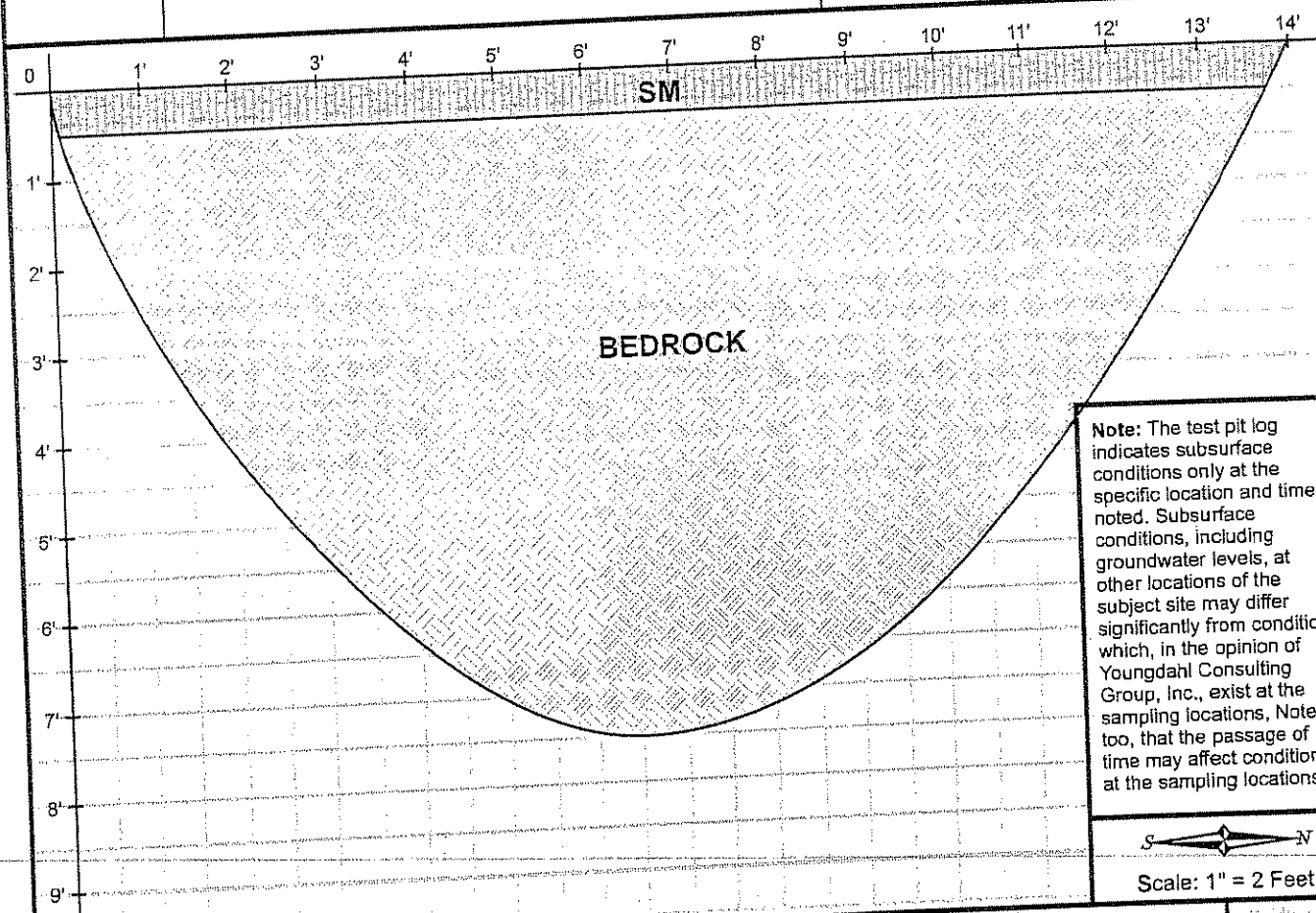

| | | | |
|---|---------------------------|--|-----------------------------|
| <p>YOUNGDAHL CONSULTING GROUP, INC. GEOTECHNICAL • ENVIRONMENTAL • MATERIALS TESTING</p> | Project No.: 07145.000 | EXPLORATORY TEST PIT LOG White Rock & Scott Road 1400 Acre Property Folsom, California | FIGURE A-3 |
| | May 2007 | | |

| | | | |
|---|----------------------------|-------------------------------|------------------------|
| Logged By: KEM | Date: 24 April 2007 | Elevation: | Pit No. TP-2 |
| Equipment: John Deere SG with 24" Bucket | | Pit Orientation: W - E | |

| Depth (Feet) | Geotechnical Description & Unified Soil Classification | Sample | Tests & Comments |
|--------------|--|--------|------------------|
| @ 0 - 1.5' | Red brown silty SAND (SM) with trace gravel, loose, slightly moist, with small roots | | NOA: 0' - 9' |
| @ 1.5' - 6' | Yellow brown metasandstone BEDROCK , completely weathered, weakly indurated, well developed fracturing, fractures closed with black staining to open at 1/2" with soil filling, moist | | |
| @ 6' - 9' | Grades gray brown, highly weathered, moderately indurated | | |
| | Test pit terminated at 9' (practical refusal) No free groundwater encountered No caving noted | | |

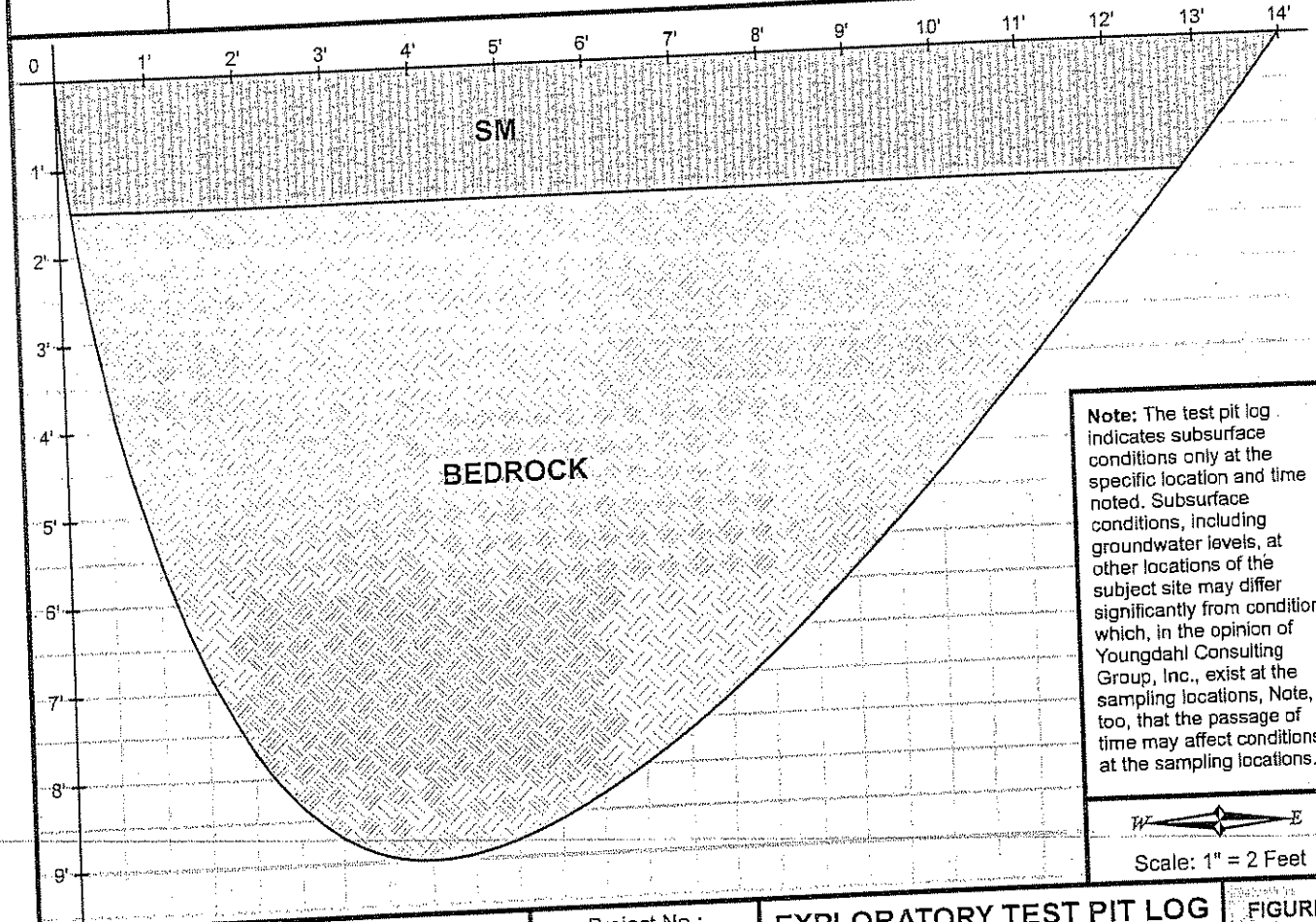

| | | | |
|---|---------------------------|--|-----------------------------|
| <p>YOUNGDAHL CONSULTING GROUP, INC. GEOTECHNICAL • ENVIRONMENTAL • MATERIALS TESTING</p> | Project No.: 07145.000 | EXPLORATORY TEST PIT LOG White Rock & Scott Road 1400 Acre Property Folsom, California | FIGURE A-4 |
| | May 2007 | | |

| Logged By: KEM | | Date: 24 April 2007 | Elevation: | Pit No. TP-3 |
|---|--|----------------------------|-------------------------------|------------------------|
| Equipment: John Deere SG with 24" Bucket | | | Pit Orientation: N - S | |
| Depth (Feet) | Geotechnical Description & Unified Soil Classification | Sample | Tests & Comments | |
| @ 0 - 0.5' | Red brown silty SAND (SM) with some gravel, loose, slightly moist, with small roots | | NOA: 0' - 5' | |
| @ 0.5' - 5' | Yellow brown to gray brown metasandstone BEDROCK , highly to moderately weathered, indurated, well developed fracturing, fractures closed with black staining to open at 1/4" with soil filling, slightly moist | | | |
| | Test pit terminated at 5' (practical refusal) No free groundwater encountered No caving noted | | | |

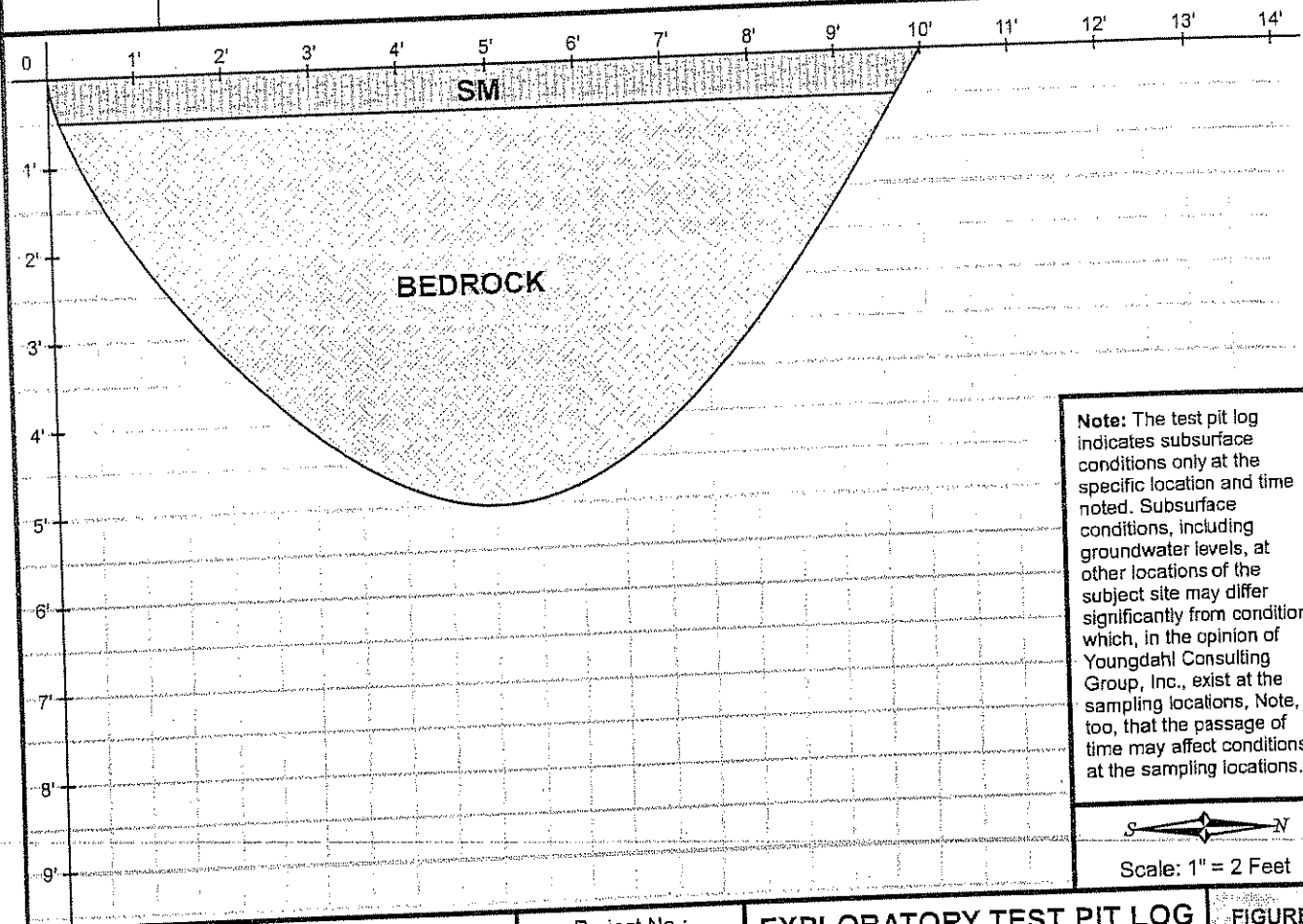

Note: The test pit log indicates subsurface conditions only at the specific location and time noted. Subsurface conditions, including groundwater levels, at other locations of the subject site may differ significantly from conditions which, in the opinion of Youngdahl Consulting Group, Inc., exist at the sampling locations. Note, too, that the passage of time may affect conditions at the sampling locations.

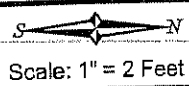

| | | | |
|---|---------------------------|--|-------------------------------------|
| <p>YOUNGDAHL CONSULTING GROUP, INC. GEOTECHNICAL • ENVIRONMENTAL • MATERIALS TESTING</p> | Project No.: 07145.000 | <p>EXPLORATORY TEST PIT LOG White Rock & Scott Road 1400 Acre Property Folsom, California</p> | <p>FIGURE A-5</p> |
| | May 2007 | | |

| | | | |
|---|----------------------------|-------------------------------|------------------------|
| Logged By: KEM | Date: 24 April 2007 | Elevation: | Pit No. TP-4 |
| Equipment: John Deere SG with 24" Bucket | | Pit Orientation: N - S | |

| Depth (Feet) | Geotechnical Description & Unified Soil Classification | Sample | Tests & Comments |
|--------------|--|--------|------------------|
| @ 0 - 1' | Dark yellow brown silty SAND (SM) with trace gravel, loose, slightly moist, with small roots | | NOA: 0' - 4' |
| @ 1' - 4' | Light yellow brown to light gray brown metasedimentary BEDROCK (SLATE) , highly weathered, indurated, well developed fracturing, fractures closed with black staining to open at 1/8" with soil filling, slightly moist | | |
| | Test pit terminated at 4' (practical refusal) No free groundwater encountered No caving noted | | |

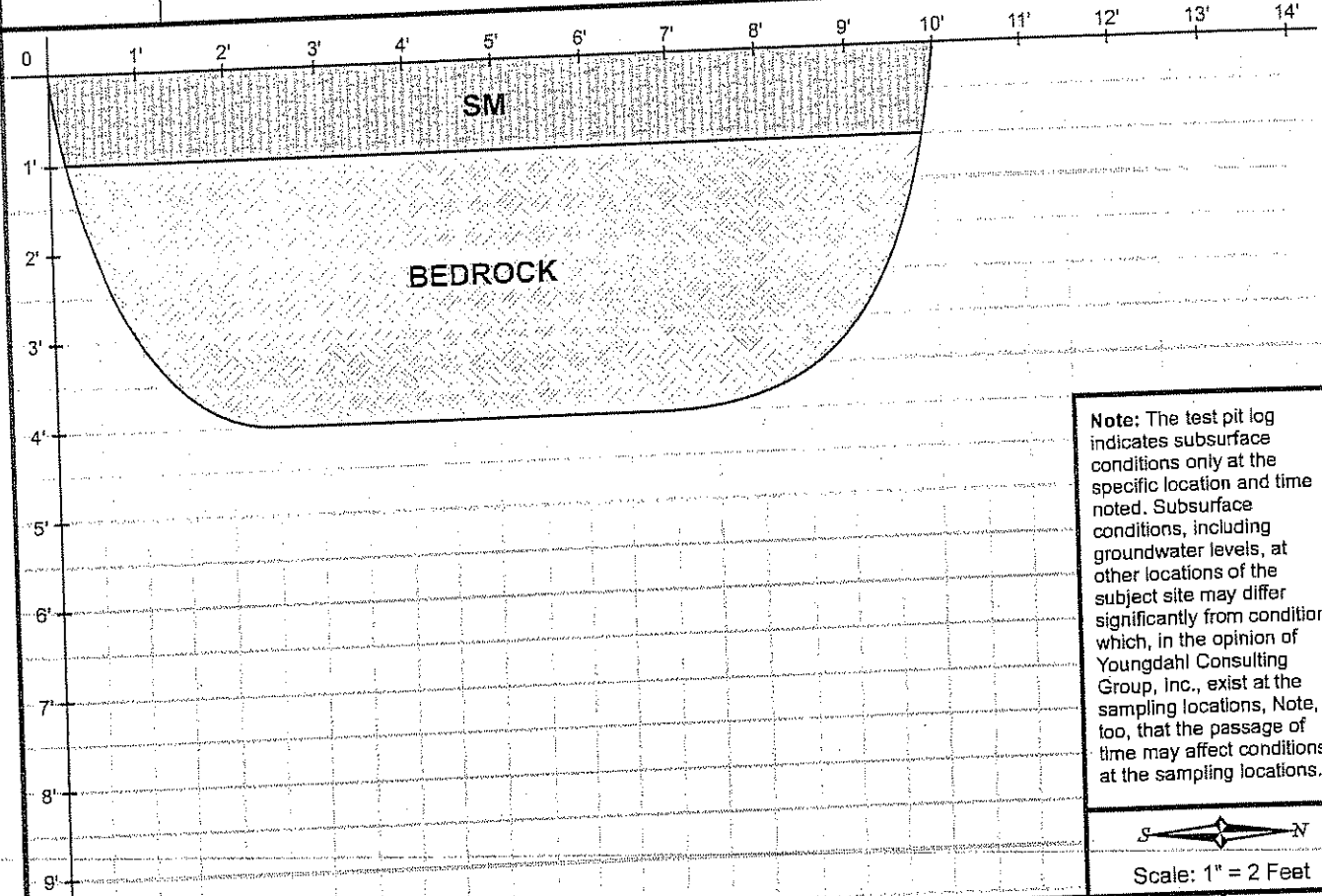

Note: The test pit log indicates subsurface conditions only at the specific location and time noted. Subsurface conditions, including groundwater levels, at other locations of the subject site may differ significantly from conditions which, in the opinion of Youngdahl Consulting Group, Inc., exist at the sampling locations. Note, too, that the passage of time may affect conditions at the sampling locations.

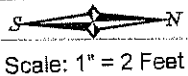

| | | | |
|---|---------------------------|--|-------------------------------------|
| <p>YOUNGDAHL CONSULTING GROUP, INC. GEOTECHNICAL • ENVIRONMENTAL • MATERIALS TESTING</p> | Project No.: 07145.000 | <p>EXPLORATORY TEST PIT LOG White Rock & Scott Road 1400 Acre Property Folsom, California</p> | <p>FIGURE A-6</p> |
| | May 2007 | | |

| | | | |
|---|----------------------------|-------------------------------|------------------------|
| Logged By: KEM | Date: 24 April 2007 | Elevation: | Pit No. TP-5 |
| Equipment: John Deere SG with 24" Bucket | | Pit Orientation: N - S | |

| Depth (Feet) | Geotechnical Description & Unified Soil Classification | Sample | Tests & Comments |
|--------------|--|--------|-----------------------|
| @ 0 - 1.5' | Red brown silty SAND (SM) with trace gravel, loose, slightly moist, with small roots | | NOA: 0' - 4.5' |
| @ 1.5' - 3' | Olive sandy CLAY (CL) with gravel, very stiff, slightly moist | | |
| @ 3' - 4.5' | Light yellow brown to light gray brown metasedimentary BEDROCK (SLATE) , highly weathered, indurated, well developed fracturing, fractures closed with black staining to open at 1/8" with soil filling, slightly moist | | |
| | Test pit terminated at 4.5' (practical refusal) No free groundwater encountered No caving noted | | |

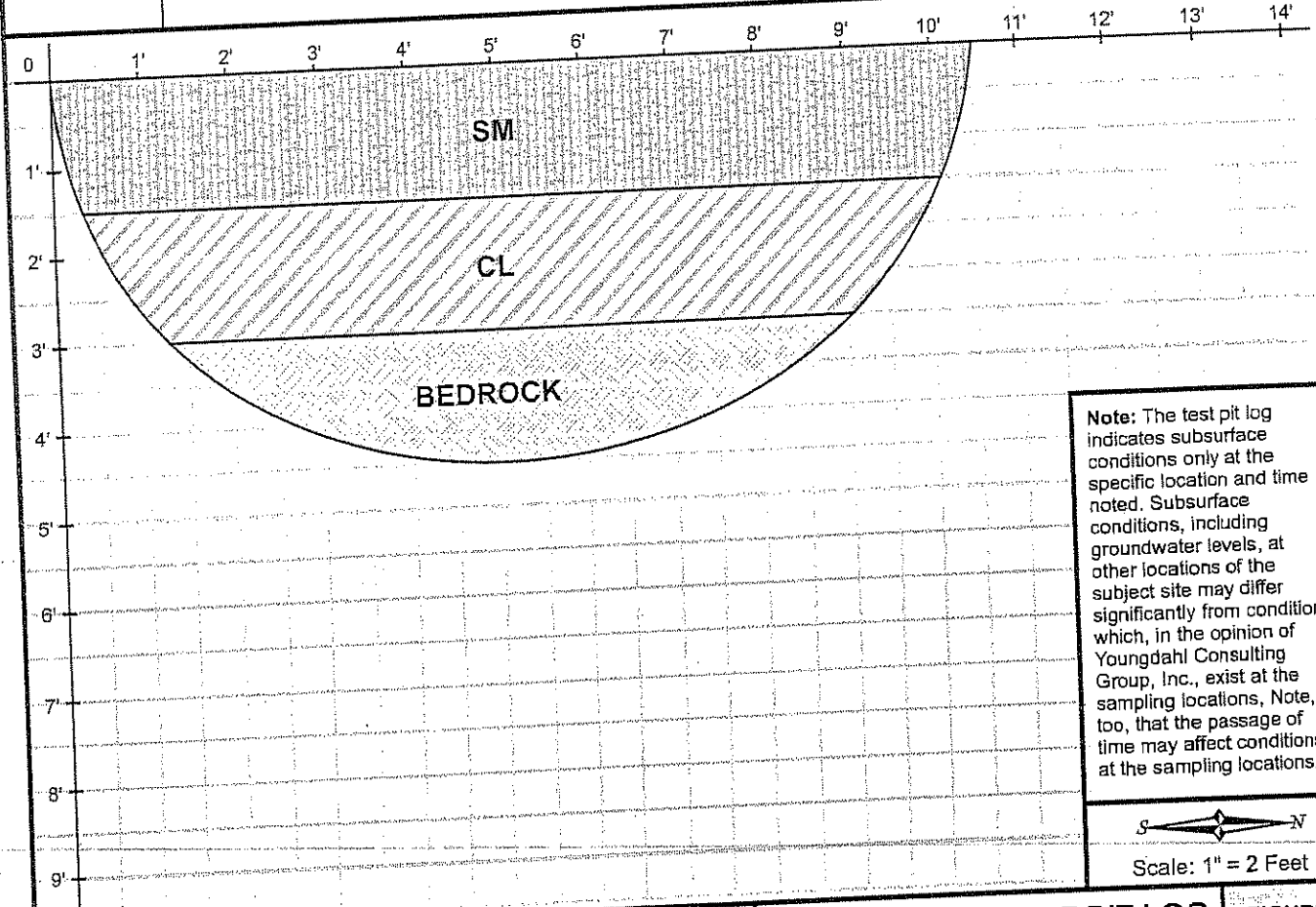

Note: The test pit log indicates subsurface conditions only at the specific location and time noted. Subsurface conditions, including groundwater levels, at other locations of the subject site may differ significantly from conditions which, in the opinion of Youngdahl Consulting Group, Inc., exist at the sampling locations. Note, too, that the passage of time may affect conditions at the sampling locations.

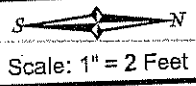

| | | | |
|---|---------------------------|--|-----------------------------|
| <p>YOUNGDAHL CONSULTING GROUP, INC. GEOTECHNICAL • ENVIRONMENTAL • MATERIALS TESTING</p> | Project No.: 07145.000 | EXPLORATORY TEST PIT LOG White Rock & Scott Road 1400 Acre Property Folsom, California | FIGURE A-7 |
| | May 2007 | | |

| | | | |
|--|---------------------|------------------------|------------------------|
| Logged By: KEM | Date: 24 April 2007 | Elevation: | Pit No. TP-6 |
| Equipment: John Deere SG with 24" Bucket | | Pit Orientation: N - S | |

| Depth (Feet) | Geotechnical Description & Unified Soil Classification | Sample | Tests & Comments |
|--------------|---|--------|------------------|
| @ 0 - 1' | Dark yellow brown silty SAND (SM) with trace gravel, loose, slightly moist, with small roots | | NOA: 0' - 3' |
| @ 1' - 3' | Light yellow brown to light gray brown metasandstone BEDROCK , highly weathered, very indurated, well developed fracturing, fractures closed with black staining to open at 1/4" with soil filling, slightly moist | | |
| | Test pit terminated at 3' (practical refusal) No free groundwater encountered No caving noted | | |

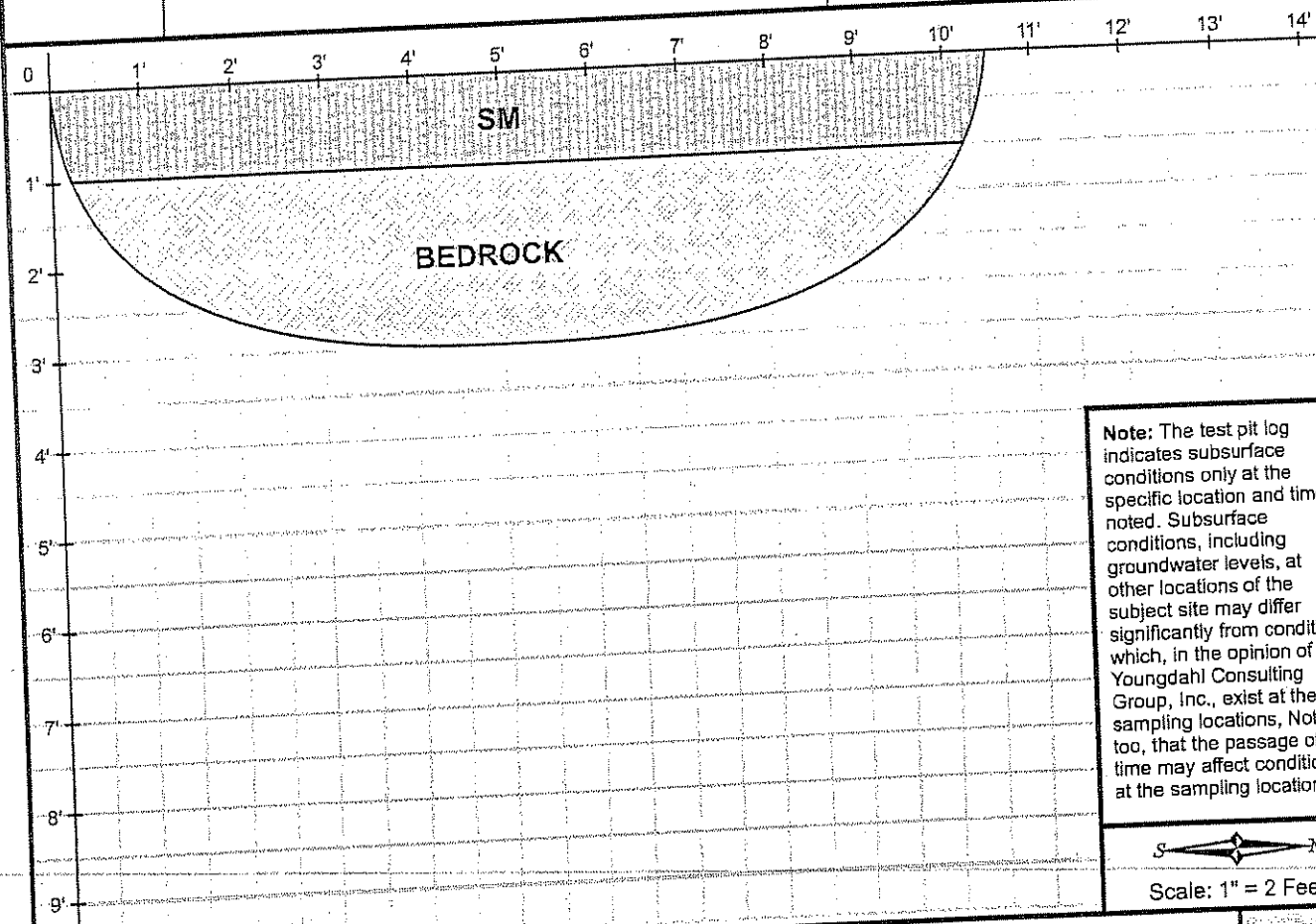

Note: The test pit log indicates subsurface conditions only at the specific location and time noted. Subsurface conditions, including groundwater levels, at other locations of the subject site may differ significantly from conditions which, in the opinion of Youngdahl Consulting Group, Inc., exist at the sampling locations. Note, too, that the passage of time may affect conditions at the sampling locations.

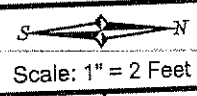

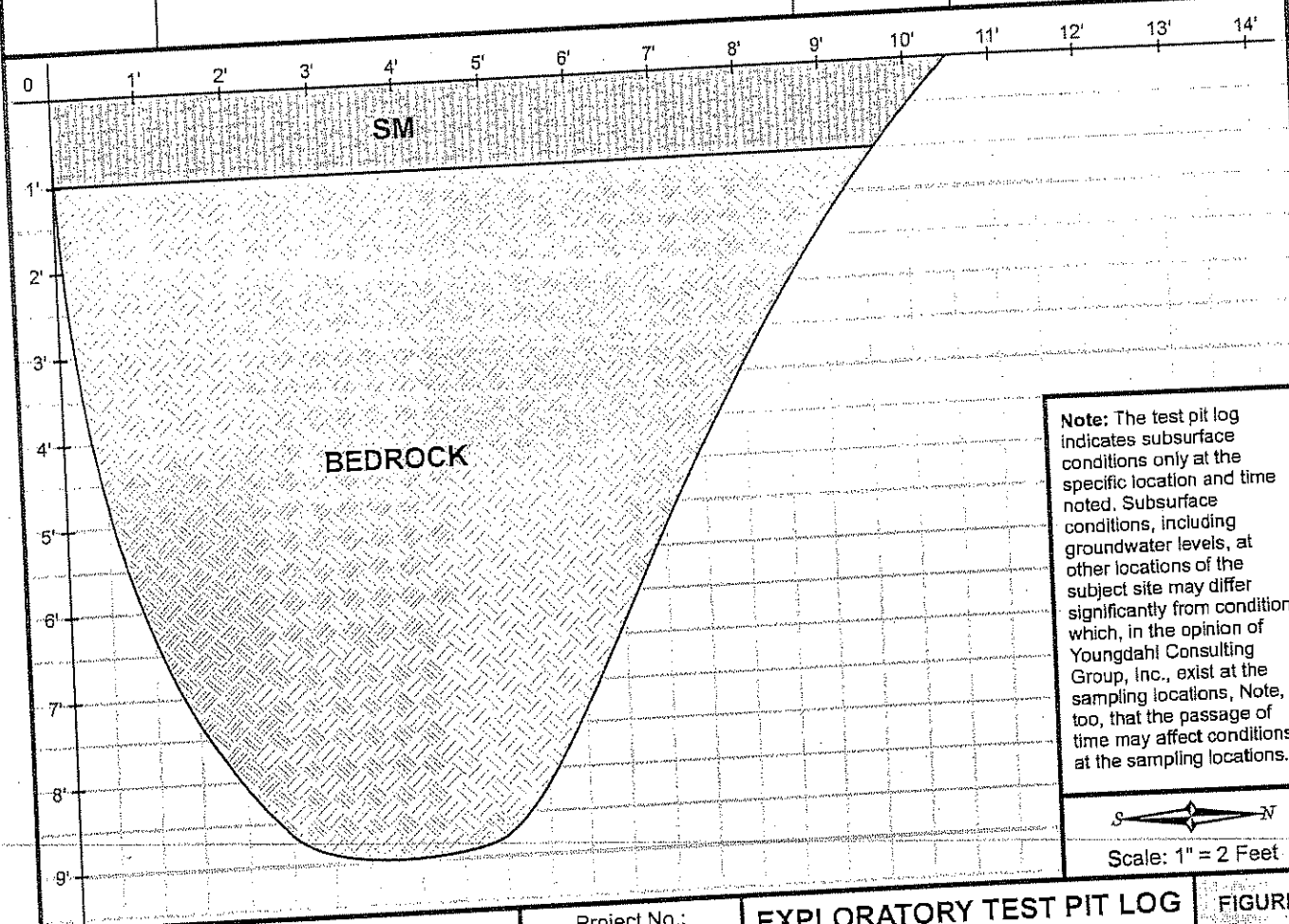

| | | | |
|--|------------------------|--|-------------------|
| | Project No.: 07145.000 | EXPLORATORY TEST PIT LOG White Rock & Scott Road 1400 Acre Property Folsom, California | FIGURE A-8 |
| | May 2007 | | |

| Logged By: KEM | | Date: 24 April 2007 | Elevation: | Pit No. TP-7 |
|---|---|-------------------------------|------------------|------------------------|
| Equipment: John Deere SG with 24" Bucket | | Pit Orientation: N - S | | |
| Depth (Feet) | Geotechnical Description & Unified Soil Classification | Sample | Tests & Comments | |
| @ 0 - 1' | Red brown silty SAND (SM) with some gravel, loose, slightly moist, with small roots | | NOA: 0' - 9' | |
| @ 1' - 5' | Yellow brown metasandstone BEDROCK , completely weathered, moderately indurated, well developed fracturing, fractures closed with black staining to open at 1/4" with soil filling, slightly moist | | | |
| @ 5' - 7' | Grades <i>light yellow brown, highly weathered, indurated</i> | | | |
| @ 7' - 9' | Grades <i>light gray brown, moderately weathered, very indurated</i> | | | |
| | Test pit terminated at 9' (practical refusal) No free groundwater encountered No caving noted | | | |



Note: The test pit log indicates subsurface conditions only at the specific location and time noted. Subsurface conditions, including groundwater levels, at other locations of the subject site may differ significantly from conditions which, in the opinion of Youngdahl Consulting Group, inc., exist at the sampling locations. Note, too, that the passage of time may affect conditions at the sampling locations.

 Scale: 1" = 2 Feet

| | | | |
|---|---------------------------|--|-----------------------------|
|  YOUNGDAHL CONSULTING GROUP, INC. <small>GEOTECHNICAL • ENVIRONMENTAL • MATERIALS TESTING</small> | Project No.: 07145.000 | EXPLORATORY TEST PIT LOG White Rock & Scott Road 1400 Acre Property Folsom, California | FIGURE A-9 |
| | May 2007 | | |

| | | | |
|---|----------------------------|-------------------------------|------------------------|
| Logged By: KEM | Date: 24 April 2007 | Elevation: | Pit No. TP-8 |
| Equipment: John Deere SG with 24" Bucket | | Pit Orientation: N - S | |

| Depth (Feet) | Geotechnical Description & Unified Soil Classification | Sample | Tests & Comments |
|---------------|--|--------|------------------|
| @ 0 - 0.5' | Red brown silty SAND (SM) with trace gravel, loose, slightly moist, with small roots | | NOA: 0' - 5.5' |
| @ 0.5' - 5.5' | Light yellow brown metasandstone BEDROCK , highly weathered, indurated, well developed fracturing, fractures closed with black staining to open at 1/8" with soil filling, slightly moist | | |
| | Test pit terminated at 5.5' (practical refusal) No free groundwater encountered No caving noted | | |

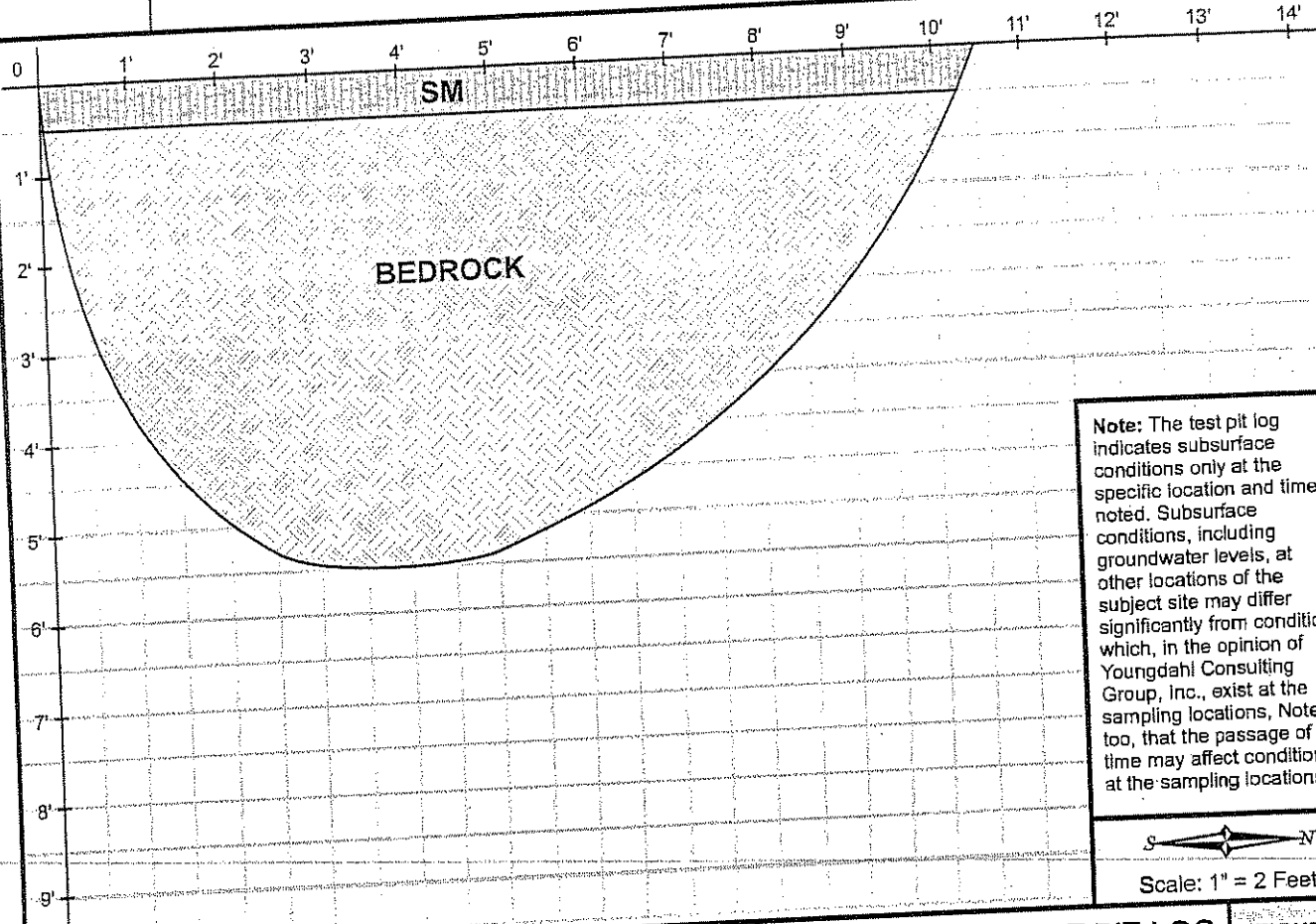

| | | | |
|---|---------------------------|--|--------------------------------------|
| <p>YOUNGDAHL CONSULTING GROUP, INC. GEOTECHNICAL • ENVIRONMENTAL • MATERIALS TESTING</p> | Project No.: 07145.000 | <p>EXPLORATORY TEST PIT LOG White Rock & Scott Road 1400 Acre Property Folsom, California</p> | <p>FIGURE A-10</p> |
| | May 2007 | | |

| Logged By: KEM | | Date: 24 April 2007 | Elevation: | Pit No. TP-9 |
|---|--|-------------------------------|------------------|------------------------|
| Equipment: John Deere SG with 24" Bucket | | Pit Orientation: N - S | | |
| Depth (Feet) | Geotechnical Description & Unified Soil Classification | Sample | Tests & Comments | |
| @ 0 - 0.5' | Red brown silty SAND (SM) with some gravel, loose, slightly moist, with small roots | | NOA: 0' - 7' | |
| @ 0.5' - 7' | Light yellow brown to light gray brown metasandstone BEDROCK , highly weathered, indurated, well developed fracturing, fractures closed with black staining to open at 1/4" with soil filling, slightly moist | | | |
| | Test pit terminated at 7' (practical refusal) No free groundwater encountered No caving noted | | | |

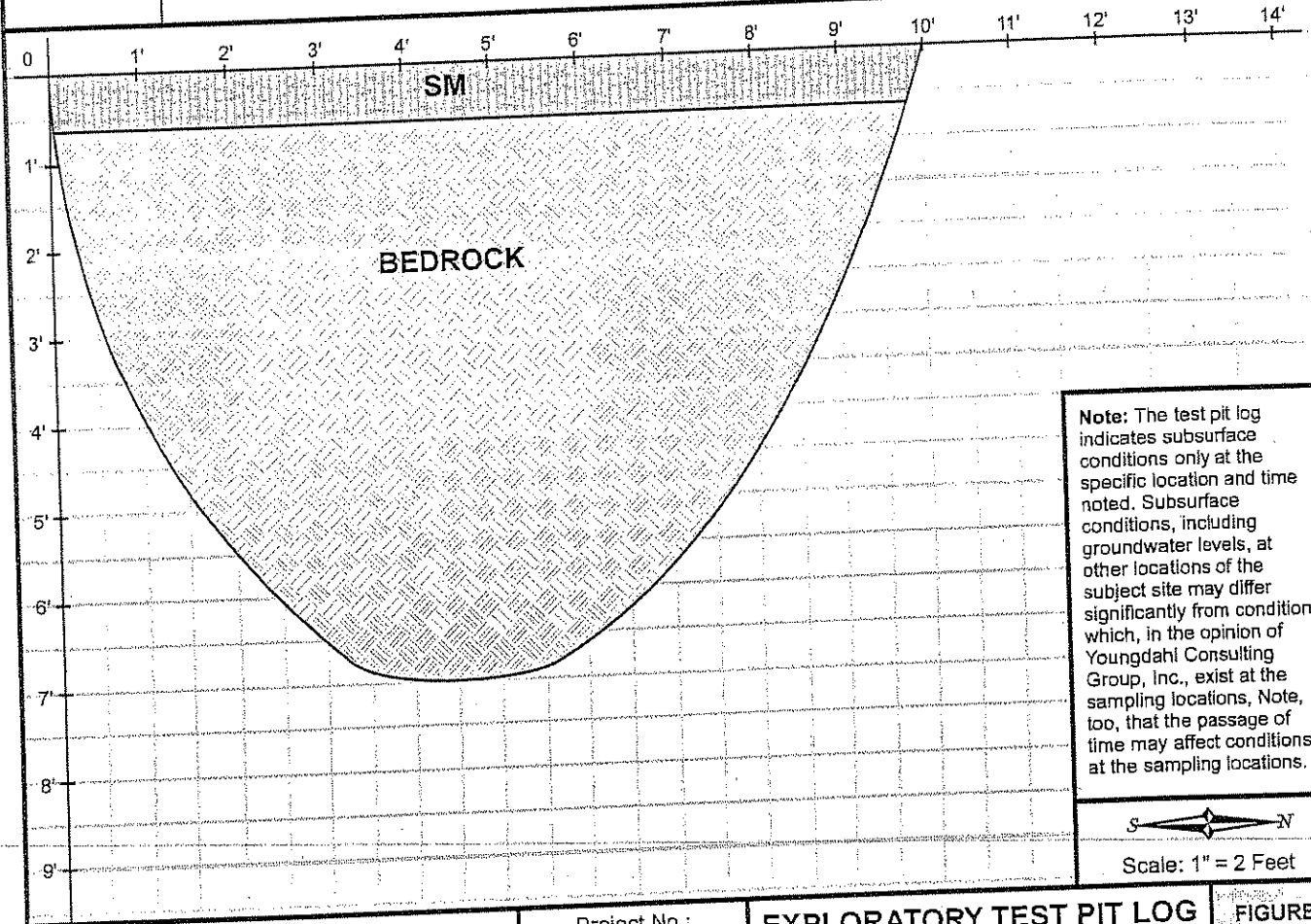

Note: The test pit log indicates subsurface conditions only at the specific location and time noted. Subsurface conditions, including groundwater levels, at other locations of the subject site may differ significantly from conditions which, in the opinion of Youngdahl Consulting Group, Inc., exist at the sampling locations. Note, too, that the passage of time may affect conditions at the sampling locations.

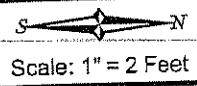

YOUNGDAHL
CONSULTING GROUP, INC.
GEOTECHNICAL • ENVIRONMENTAL • MATERIALS TESTING

Project No.:
07145.000
May 2007

EXPLORATORY TEST PIT LOG
White Rock & Scott Road
1400 Acre Property
Folsom, California

FIGURE
A-11

| | | | |
|--|---------------------|------------------------|-------------------------|
| Logged By: KEM | Date: 24 April 2007 | Elevation: | Pit No. TP-10 |
| Equipment: John Deere SG with 24" Bucket | | Pit Orientation: N - S | |

| Depth (Feet) | Geotechnical Description & Unified Soil Classification | Sample | Tests & Comments |
|--------------|--|--------|------------------|
| @ 0 - 1' | Red brown silty SAND (SM) with some gravel, loose, slightly moist, with small roots | | NOA: 0' - 3.5' |
| @ 1' - 3.5' | Yellow brown metasandstone BEDROCK , highly to moderately weathered, indurated to very indurated, well developed fracturing, fractures closed with black staining to open at 1/4" with soil filling, slightly moist | | |
| | Test pit terminated at 3.5' (practical refusal) No free groundwater encountered No caving noted | | |

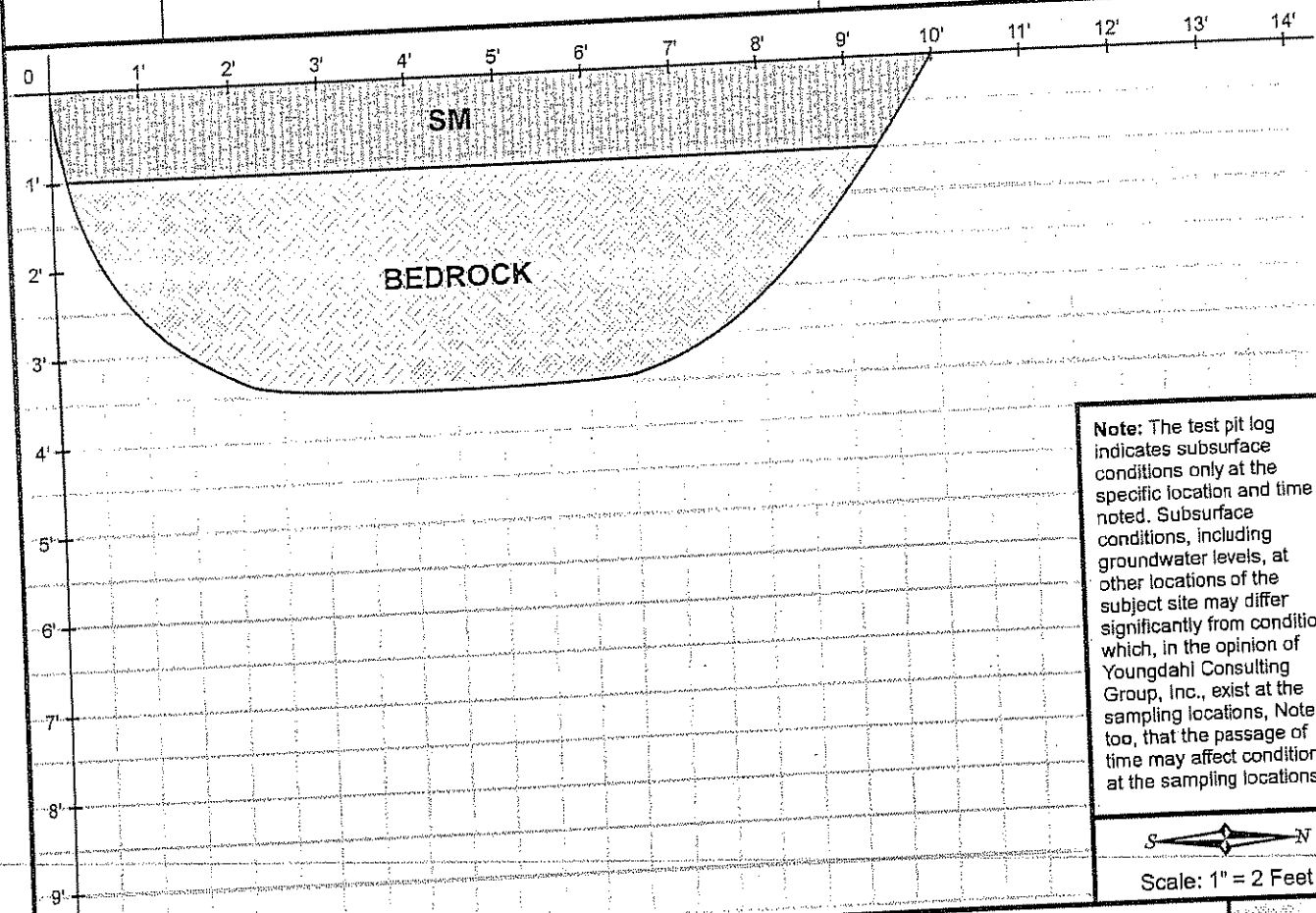

Note: The test pit log indicates subsurface conditions only at the specific location and time noted. Subsurface conditions, including groundwater levels, at other locations of the subject site may differ significantly from conditions which, in the opinion of Youngdahl Consulting Group, Inc., exist at the sampling locations. Note, too, that the passage of time may affect conditions at the sampling locations.

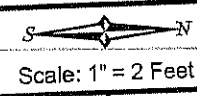

| | | | |
|--|------------------------|--|--------------------|
| | Project No.: 07145.000 | EXPLORATORY TEST PIT LOG White Rock & Scott Road 1400 Acre Property Folsom, California | FIGURE A-12 |
| | May 2007 | | |

| | | | |
|--|---------------------|------------------------|-------------------------|
| Logged By: KEM | Date: 24 April 2007 | Elevation: | Pit No. TP-11 |
| Equipment: John Deere SG with 24" Bucket | | Pit Orientation: N - S | |

| Depth (Feet) | Geotechnical Description & Unified Soil Classification | Sample | Tests & Comments |
|--------------|--|--------|------------------|
| @ 0 - 1' | Red brown silty SAND (SM) with trace gravel, loose, slightly moist, with small roots | | NOA: 0' - 3.5' |
| @ 1' - 3.5' | Light yellow brown metasandstone BEDROCK , highly weathered, indurated, well developed fracturing, fractures closed with black staining to open at 1/8" with soil filling, slightly moist | | |
| | Test pit terminated at 3.5' (practical refusal) No free groundwater encountered No caving noted | | |

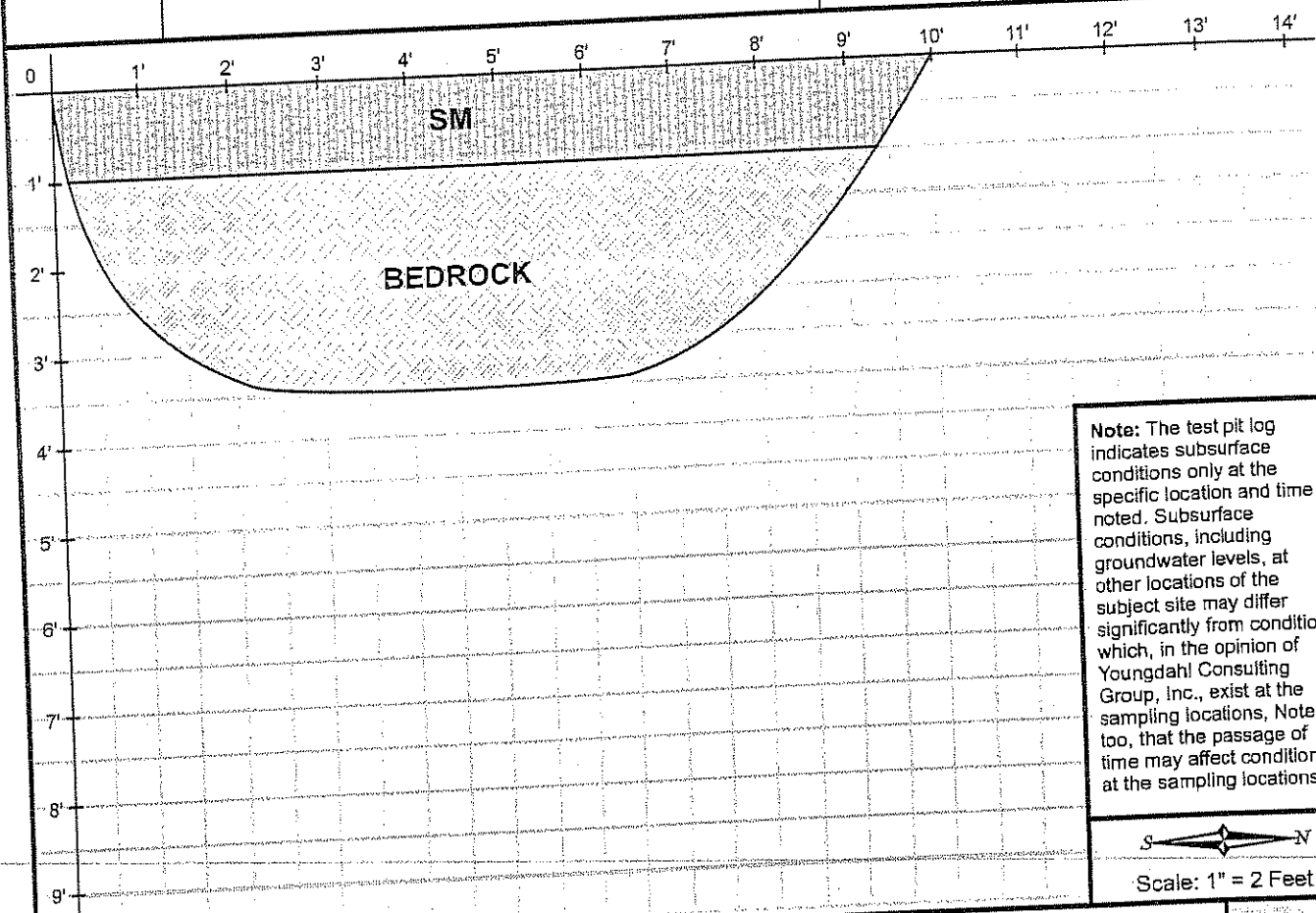

Note: The test pit log indicates subsurface conditions only at the specific location and time noted. Subsurface conditions, including groundwater levels, at other locations of the subject site may differ significantly from conditions which, in the opinion of Youngdahl Consulting Group, Inc., exist at the sampling locations. Note, too, that the passage of time may affect conditions at the sampling locations.

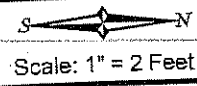

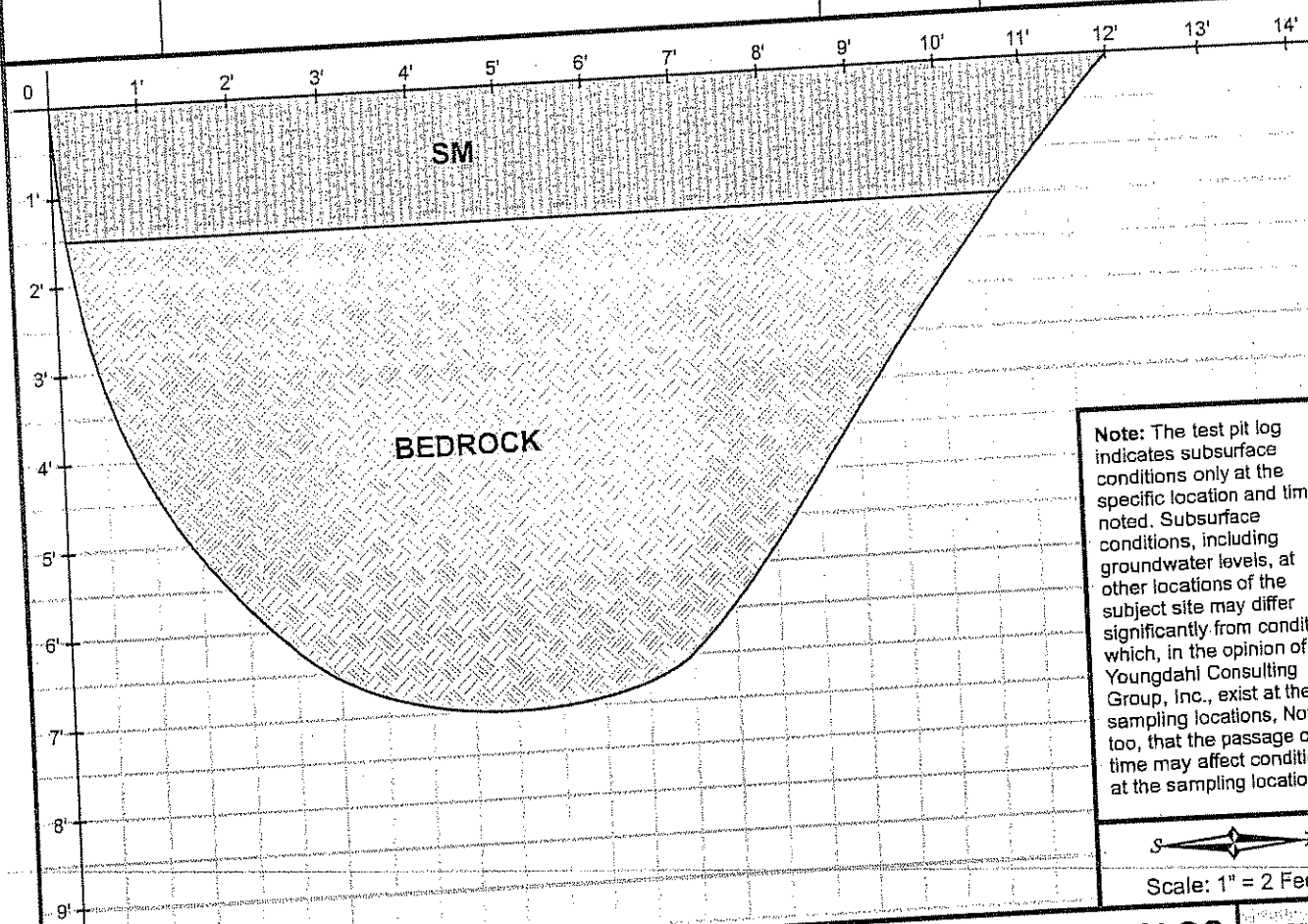

| | | | |
|---|------------------------|--|--------------------------------------|
| <p>YOUNGDAHL CONSULTING GROUP, INC. GEOTECHNICAL • ENVIRONMENTAL • MATERIALS TESTING</p> | Project No.: 07145.000 | <p>EXPLORATORY TEST PIT LOG White Rock & Scott Road 1400 Acre Property Folsom, California</p> | <p>FIGURE A-13</p> |
| | May 2007 | | |

| Logged By: KEM | | Date: 24 April 2007 | Elevation: | Pit No. TP-12 |
|---|---|----------------------------|-------------------------------|-------------------------|
| Equipment: John Deere SG with 24" Bucket | | | Pit Orientation: N - S | |
| Depth (Feet) | Geotechnical Description & Unified Soil Classification | Sample | Tests & Comments | |
| @ 0 - 1.5' | Red brown silty SAND (SM) with trace gravel, loose, slightly moist, with small roots | | NOA: 0' - 7' | |
| @ 1.5' - 7' | Yellow brown metasandstone BEDROCK , completely weathered, weakly indurated, moderately developed fracturing, fractures closed with black staining to open at 1/4" with soil filling, slightly moist | | | |
| | Test pit terminated at 7' (practical refusal) No free groundwater encountered No caving noted | | | |



Note: The test pit log indicates subsurface conditions only at the specific location and time noted. Subsurface conditions, including groundwater levels, at other locations of the subject site may differ significantly from conditions which, in the opinion of Youngdahl Consulting Group, Inc., exist at the sampling locations. Note, too, that the passage of time may affect conditions at the sampling locations.

 Scale: 1" = 2 Feet

| | | | |
|---|---------------------------|--|------------------------------|
|  YOUNGDAHL CONSULTING GROUP, INC. <small>GEOTECHNICAL • ENVIRONMENTAL • MATERIALS TESTING</small> | Project No.: 07145.000 | EXPLORATORY TEST PIT LOG White Rock & Scott Road 1400 Acre Property Folsom, California | FIGURE A-14 |
| | May 2007 | | |

| | | | |
|---|----------------------------|-------------------------------|-------------------------|
| Logged By: KEM | Date: 24 April 2007 | Elevation: | Pit No. TP-13 |
| Equipment: John Deere SG with 24" Bucket | | Pit Orientation: N - S | |

| Depth (Feet) | Geotechnical Description & Unified Soil Classification | Sample | Tests & Comments |
|--------------|---|--------|------------------|
| @ 0 - 1' | Strong brown silty SAND (SM) with trace clay and gravel, loose, slightly moist, with small roots | | NOA: 0' - 4.5' |
| @ 1' - 4' | Gray brown metasedimentary BEDROCK (SLATE) , completely weathered, moderately indurated, moderately developed fracturing, fractures open to 1/2" with clay filling, slightly moist | | |
| @ 4' - 4.5' | <i>Grades highly weathered, indurated</i> | | |
| | Test pit terminated at 4.5' (practical refusal) No free groundwater encountered No caving noted | | |

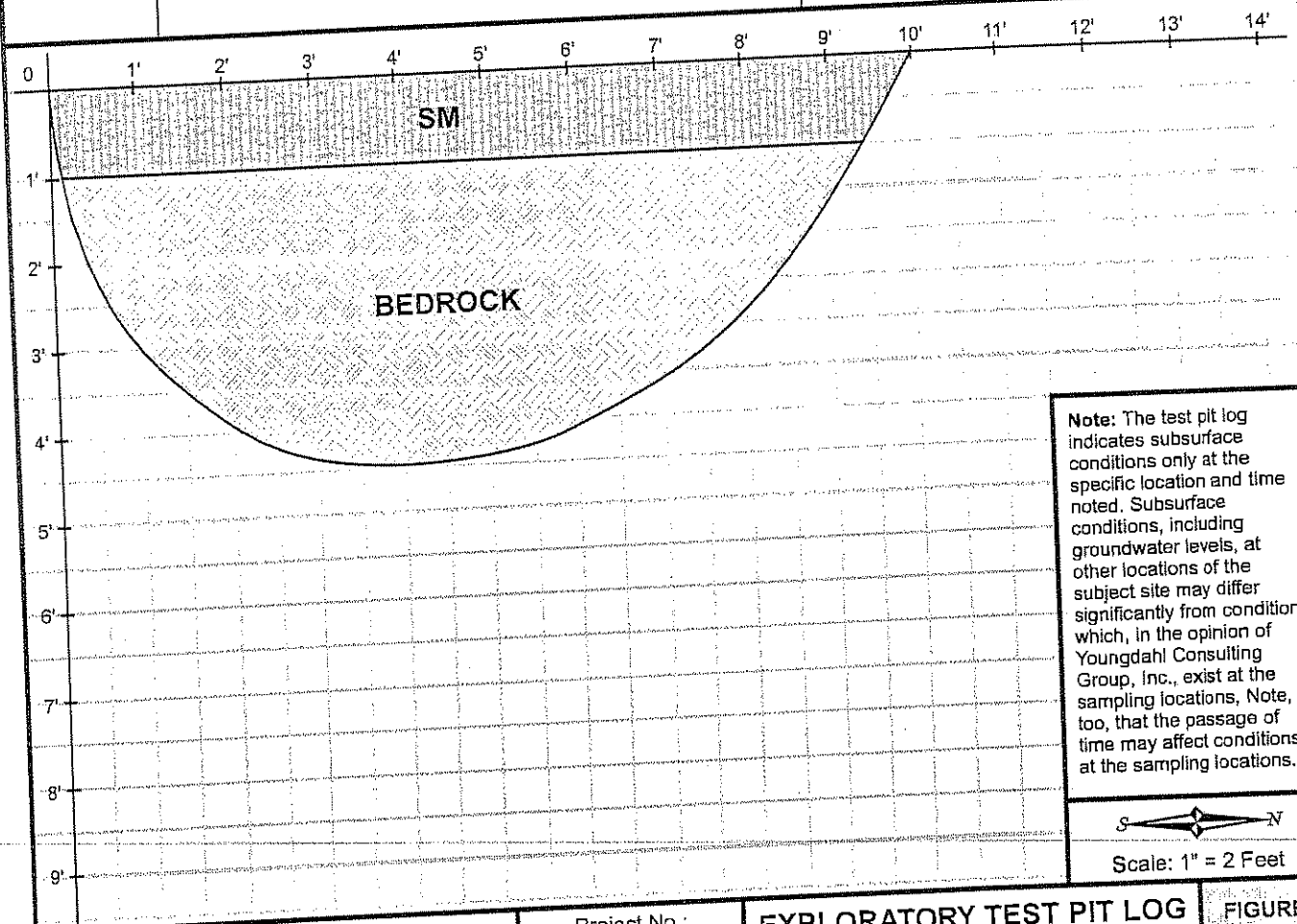

Note: The test pit log indicates subsurface conditions only at the specific location and time noted. Subsurface conditions, including groundwater levels, at other locations of the subject site may differ significantly from conditions which, in the opinion of Youngdahl Consulting Group, Inc., exist at the sampling locations. Note, too, that the passage of time may affect conditions at the sampling locations.

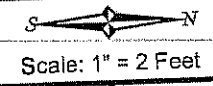

| | | | |
|---|---------------------------|--|--------------------------------------|
| <p>YOUNGDAHL CONSULTING GROUP, INC. GEOTECHNICAL • ENVIRONMENTAL • MATERIALS TESTING</p> | Project No.: 07145.000 | <p>EXPLORATORY TEST PIT LOG White Rock & Scott Road 1400 Acre Property Folsom, California</p> | <p>FIGURE A-15</p> |
| | May 2007 | | |

| | | | |
|--|---------------------|------------------------|-------------------------|
| Logged By: KEM | Date: 24 April 2007 | Elevation: | Pit No. TP-14 |
| Equipment: John Deere SG with 24" Bucket | | Pit Orientation: W - E | |

| Depth (Feet) | Geotechnical Description & Unified Soil Classification | Sample | Tests & Comments |
|--------------|---|--------|------------------|
| @ 0 - 1.5' | Red brown sandy SILT (ML) with trace gravel, medium stiff, slightly moist, with small roots | | NOA: 0' - 5' |
| @ 1.5' - 4' | Gray brown metasedimentary BEDROCK (SLATE) , completely weathered, moderately indurated, moderately developed fracturing, fractures open to 1/2" with clay filling, slightly moist | | |
| @ 4' - 5' | <i>Grades highly weathered, indurated</i> | | |
| | Test pit terminated at 5' (practical refusal) No free groundwater encountered No caving noted | | |

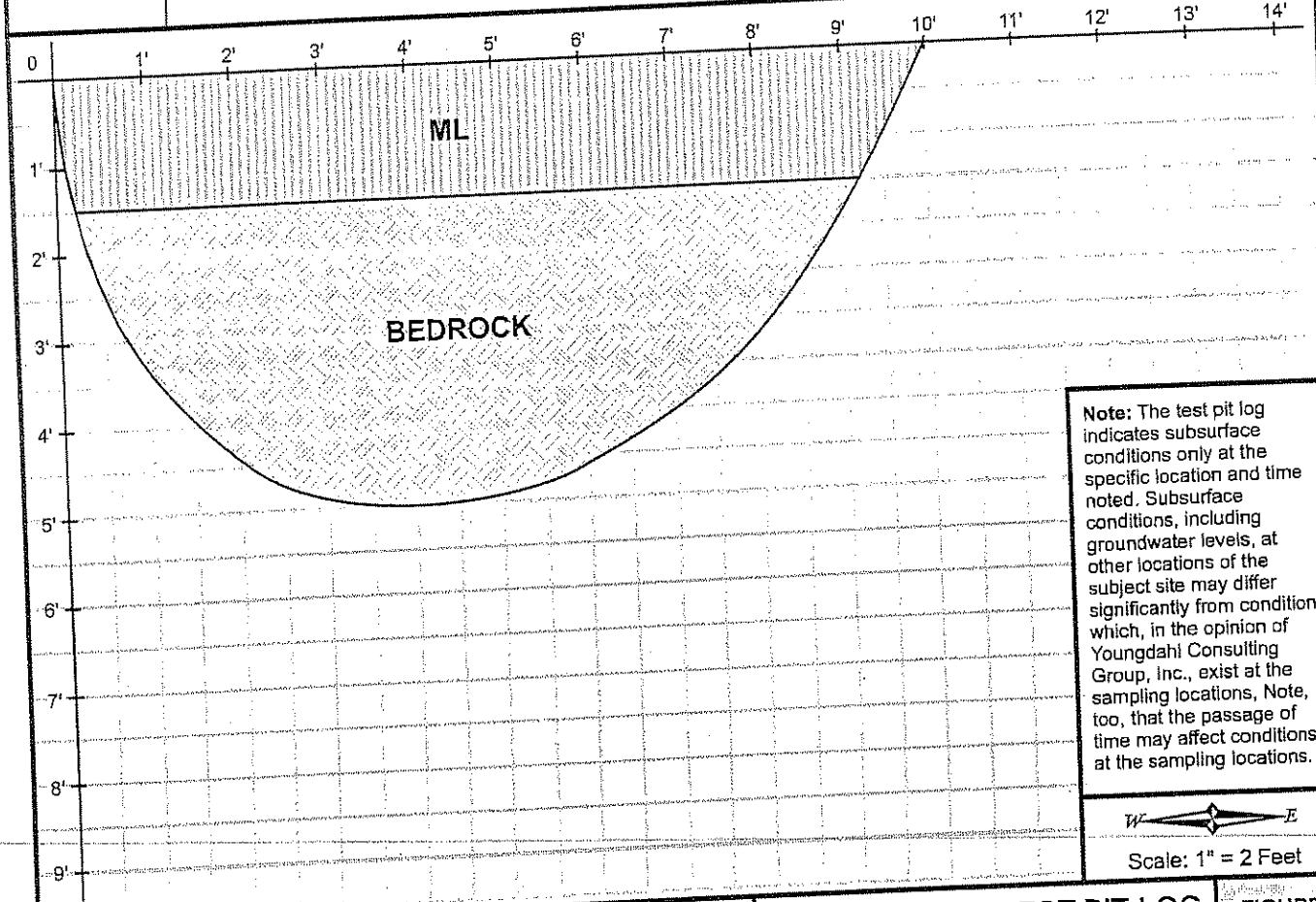

Note: The test pit log indicates subsurface conditions only at the specific location and time noted. Subsurface conditions, including groundwater levels, at other locations of the subject site may differ significantly from conditions which, in the opinion of Youngdahl Consulting Group, Inc., exist at the sampling locations. Note, too, that the passage of time may affect conditions at the sampling locations.

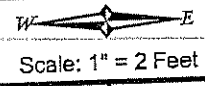

Project No.: 07145.000
May 2007

EXPLORATORY TEST PIT LOG
White Rock & Scott Road
1400 Acre Property
Folsom, California

FIGURE A-16

| | | | |
|---|----------------------------|-------------------------------|-------------------------|
| Logged By: KEM | Date: 24 April 2007 | Elevation: | Pit No. TP-15 |
| Equipment: John Deere SG with 24" Bucket | | Pit Orientation: N - S | |

| Depth (Feet) | Geotechnical Description & Unified Soil Classification | Sample | Tests & Comments |
|---------------|---|--------|------------------|
| @ 0 - 1.5' | Red brown silty SAND (SM) with trace gravel, loose, slightly moist, with small roots | | NOA: 0' - 4' |
| @ 1.5' - 2.5' | Gray brown metasedimentary BEDROCK (SLATE) , completely weathered, moderately indurated, moderately developed fracturing, fractures open to 1/2" with clay filling, slightly moist | | |
| @ 2.5' - 4' | <i>Grades highly weathered, indurated</i> | | |
| | Test pit terminated at 4' (practical refusal) No free groundwater encountered No caving noted | | |

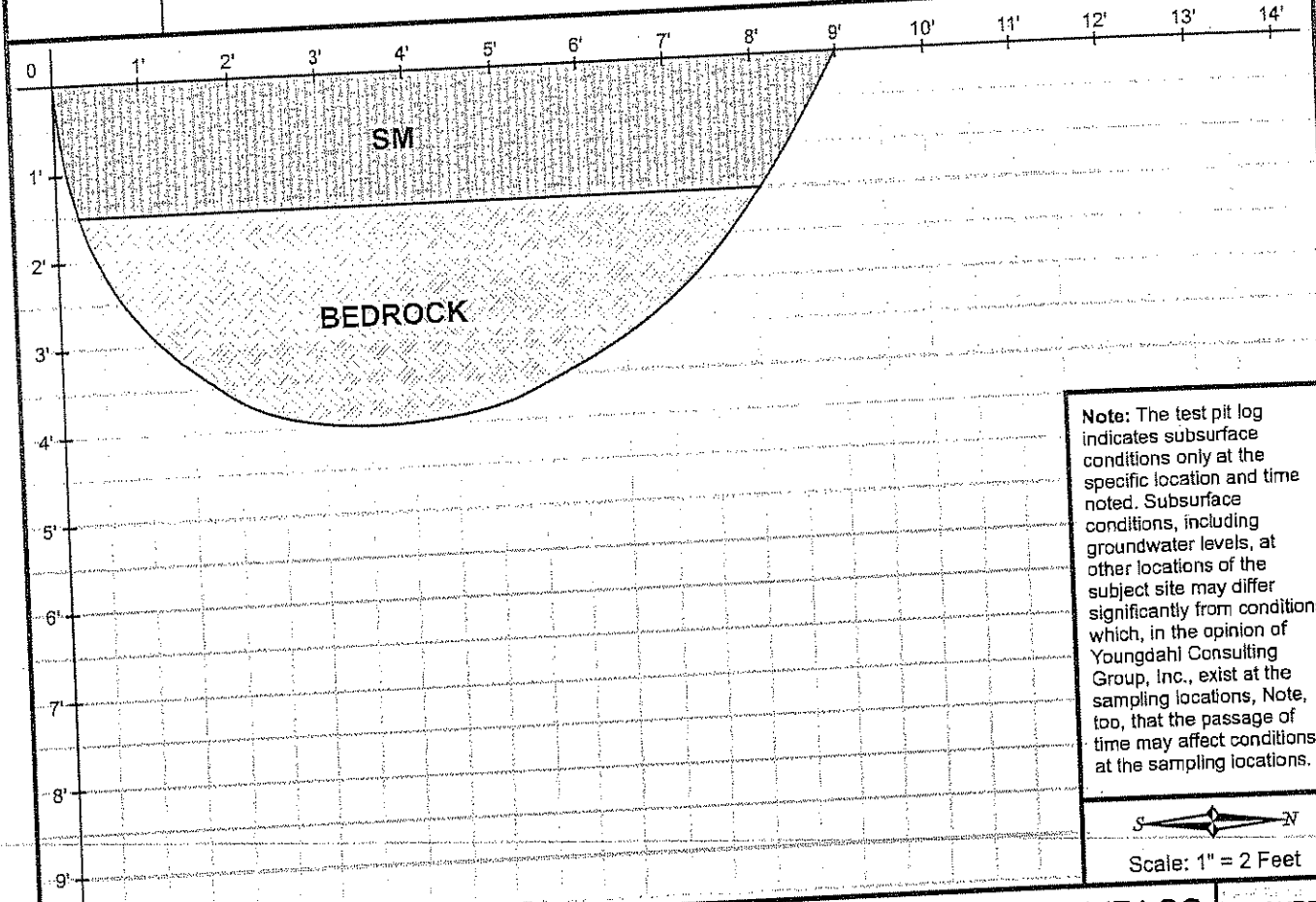

Note: The test pit log indicates subsurface conditions only at the specific location and time noted. Subsurface conditions, including groundwater levels, at other locations of the subject site may differ significantly from conditions which, in the opinion of Youngdahl Consulting Group, Inc., exist at the sampling locations. Note, too, that the passage of time may affect conditions at the sampling locations.

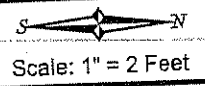

| | | | |
|---|---------------------------|--|--------------------------------------|
| <p>YOUNGDAHL CONSULTING GROUP, INC. GEOTECHNICAL • ENVIRONMENTAL • MATERIALS TESTING</p> | Project No.: 07145.000 | <p>EXPLORATORY TEST PIT LOG White Rock & Scott Road 1400 Acre Property Folsom, California</p> | <p>FIGURE A-17</p> |
| | May 2007 | | |

| | | | |
|---|----------------------------|-------------------------------|-------------------------|
| Logged By: KEM | Date: 24 April 2007 | Elevation: | Pit No. TP-16 |
| Equipment: John Deere SG with 24" Bucket | | Pit Orientation: W - E | |

| Depth (Feet) | Geotechnical Description & Unified Soil Classification | Sample | Tests & Comments |
|--------------|---|--------|------------------|
| @ 0 - 0.5' | Red brown sandy SILT (ML) with trace gravel, medium stiff, slightly moist, with small roots | | NOA: 0' - 3' |
| @ 0.5' - 3' | Gray brown metasandstone BEDROCK , highly to moderately weathered, very indurated, poorly developed foliation, moderately developed fracturing, foliation and fractures closed to open to 1/4" with soil filling, slightly moist | | |
| | Test pit terminated at 3' (practical refusal) No free groundwater encountered No caving noted | | |

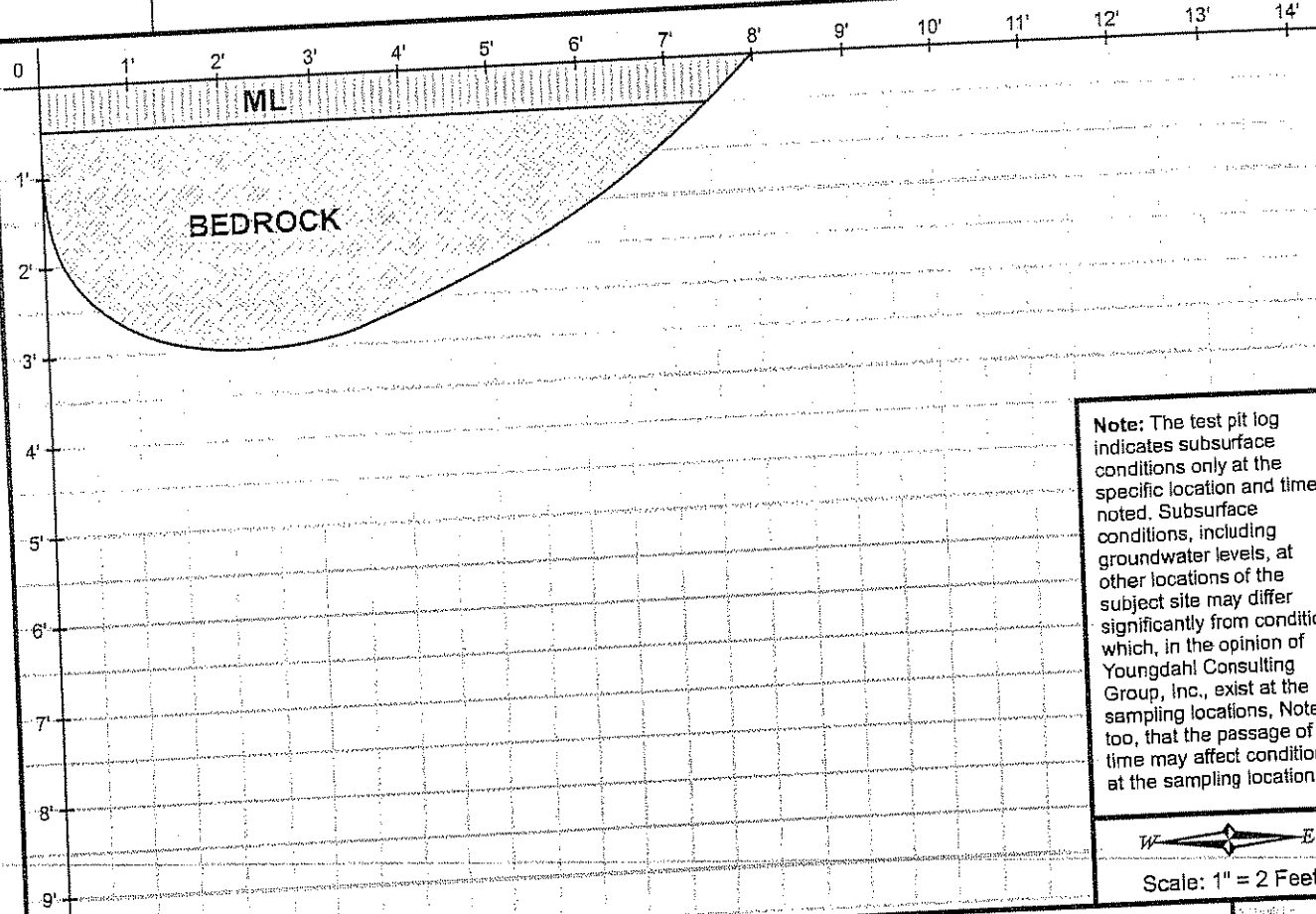

Note: The test pit log indicates subsurface conditions only at the specific location and time noted. Subsurface conditions, including groundwater levels, at other locations of the subject site may differ significantly from conditions which, in the opinion of Youngdahl Consulting Group, Inc., exist at the sampling locations. Note, too, that the passage of time may affect conditions at the sampling locations.

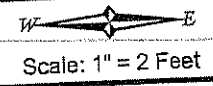

| | | | |
|--|---------------------------|--|------------------------------|
| | Project No.: 07145.000 | EXPLORATORY TEST PIT LOG White Rock & Scott Road 1400 Acre Property Folsom, California | FIGURE A-18 |
| | May 2007 | | |

| | | | |
|---|----------------------------|-------------------------------|-------------------------|
| Logged By: KEM | Date: 24 April 2007 | Elevation: | Pit No. TP-17 |
| Equipment: John Deere SG with 24" Bucket | | Pit Orientation: W - E | |

| Depth (Feet) | Geotechnical Description & Unified Soil Classification | Sample | Tests & Comments |
|---------------|--|--------|------------------|
| @ 0 - 1.5' | Red brown silty SAND (SM) with trace gravel, medium stiff, slightly moist, with small roots | | NOA: 0' - 5.5' |
| @ 0.5' - 5.5' | Gray brown metasandstone BEDROCK , highly weathered, indurated, moderately developed fracturing, fractures closed to open to 1/4" with soil filling, slightly moist | | |
| | Test pit terminated at 5.5' (practical refusal) No free groundwater encountered No caving noted | | |

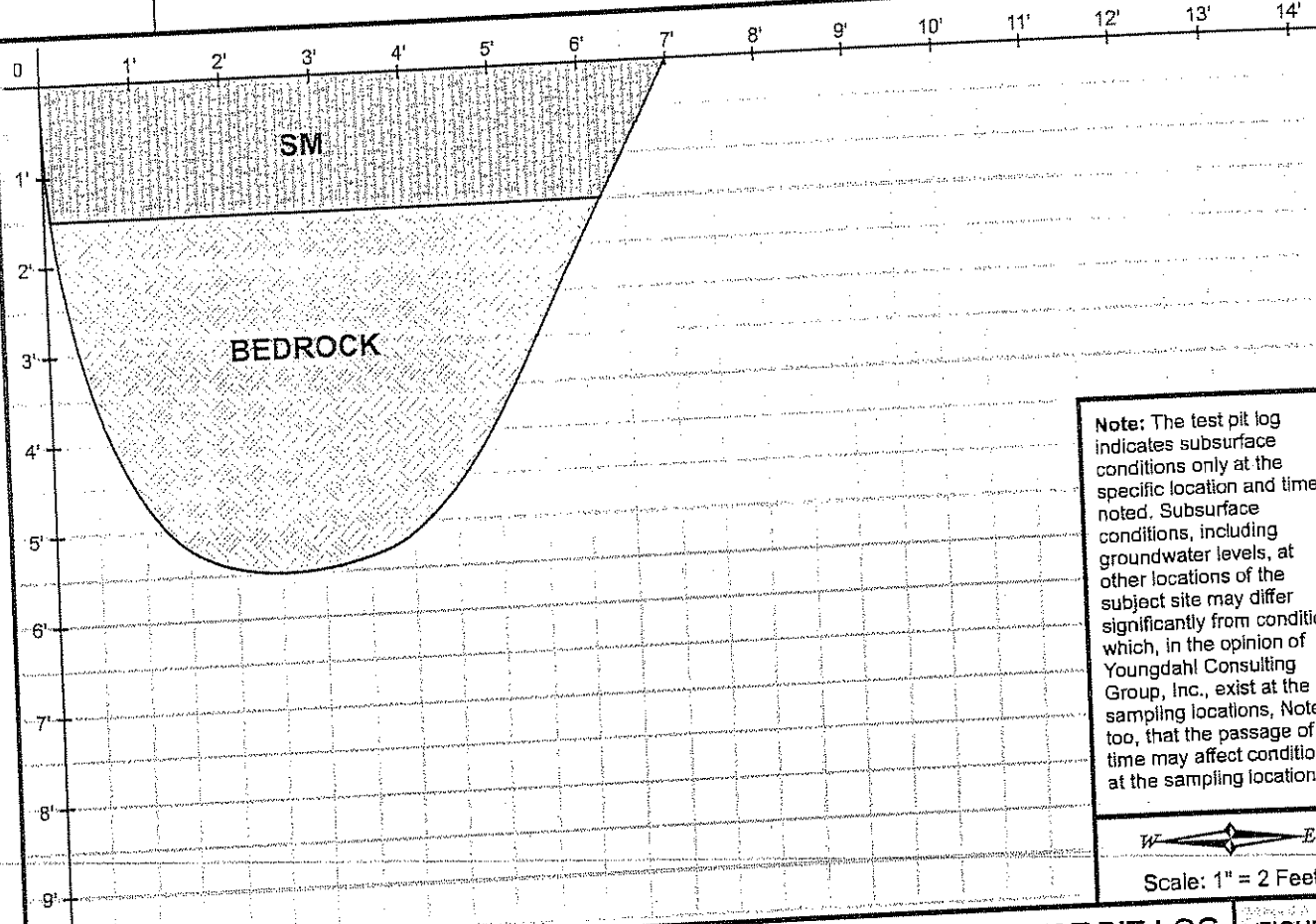

Note: The test pit log indicates subsurface conditions only at the specific location and time noted. Subsurface conditions, including groundwater levels, at other locations of the subject site may differ significantly from conditions which, in the opinion of Youngdahl Consulting Group, Inc., exist at the sampling locations. Note, too, that the passage of time may affect conditions at the sampling locations.

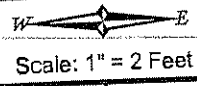

| | | | |
|--|---------------------------|--|--------------------|
| GEOTECHNICAL • ENVIRONMENTAL • MATERIALS TESTING | Project No.: 07145.000 | EXPLORATORY TEST PIT LOG White Rock & Scott Road 1400 Acre Property Folsom, California | FIGURE A-19 |
| | May 2007 | | |

| | | | |
|--|---------------------|------------------------|-------------------------|
| Logged By: KEM | Date: 24 April 2007 | Elevation: | Pit No. TP-18 |
| Equipment: John Deere SG with 24" Bucket | | Pit Orientation: S - N | |

| Depth (Feet) | Geotechnical Description & Unified Soil Classification | Sample | Tests & Comments |
|--------------|--|--------|---|
| @ 0 - 1' | Light brown sandy SILT (ML) with trace gravel, medium stiff, slightly moist, with small roots | | NOA: 0' - 8' <i>Geothermal Alteration Zone (Quartz Outcrop Adjacent To Test Pit)</i> |
| @ 1' - 6' | Light yellow brown metasedimentary BEDROCK (SLATE) , completely weathered, weakly indurated, poorly developed fracturing, fractures closed to open to 1/4" with soil and clay filling, slightly moist | | |
| @ 6' - 8' | <i>Grades highly weathered, moderately indurated</i> | | |
| | Test pit terminated at 8' (practical refusal) No free groundwater encountered No caving noted | | |

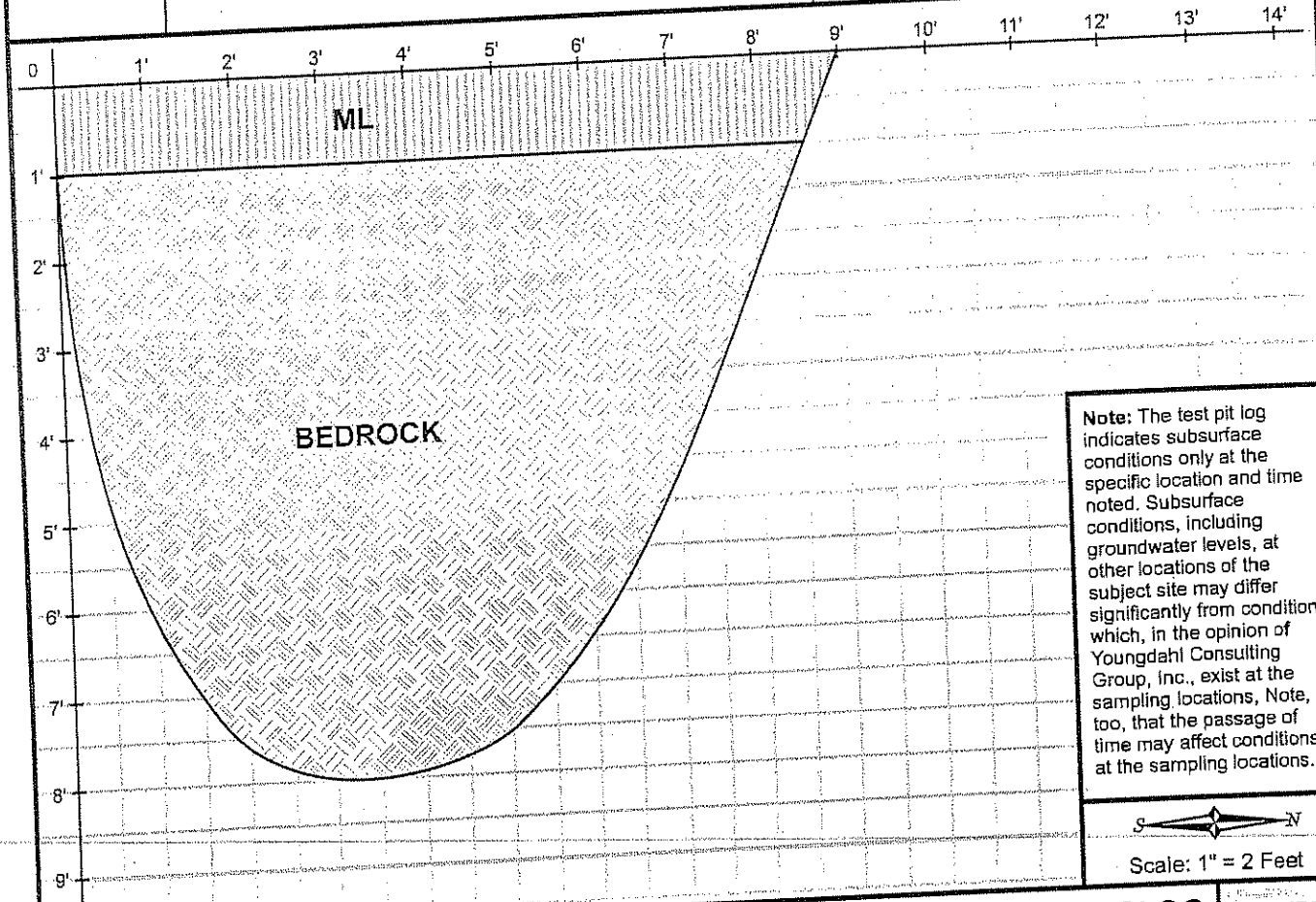

Note: The test pit log indicates subsurface conditions only at the specific location and time noted. Subsurface conditions, including groundwater levels, at other locations of the subject site may differ significantly from conditions which, in the opinion of Youngdahl Consulting Group, Inc., exist at the sampling locations. Note, too, that the passage of time may affect conditions at the sampling locations.

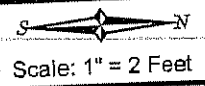

| | | | |
|--|------------------------|--|--------------------|
| | Project No.: 07145.000 | EXPLORATORY TEST PIT LOG White Rock & Scott Road 1400 Acre Property Folsom, California | FIGURE A-20 |
| | May 2007 | | |

| | | | |
|---|----------------------------|-------------------------------|-------------------------|
| Logged By: KEM | Date: 24 April 2007 | Elevation: | Pit No. TP-19 |
| Equipment: John Deere SG with 24" Bucket | | Pit Orientation: W - E | |

| Depth (Feet) | Geotechnical Description & Unified Soil Classification | Sample | Tests & Comments |
|--------------|---|--------|---|
| @ 0 - 1' | Brown silty SAND (SM) with trace gravel, loose, slightly moist, with small roots | | NOA: 0' - 6' <i>Geothermal Alteration Zone Small Quartz Veins Observed</i> |
| @ 1' - 4.5' | Gray brown metasedimentary BEDROCK (SLATE) , completely weathered, weakly indurated, poorly developed fracturing, fractures closed to open to 1/4" with clay filling, slightly moist | | |
| @ 4.5' - 6' | <i>Grades highly weathered, moderately indurated</i> | | |
| | Test pit terminated at 6' (practical refusal) No free groundwater encountered No caving noted | | |

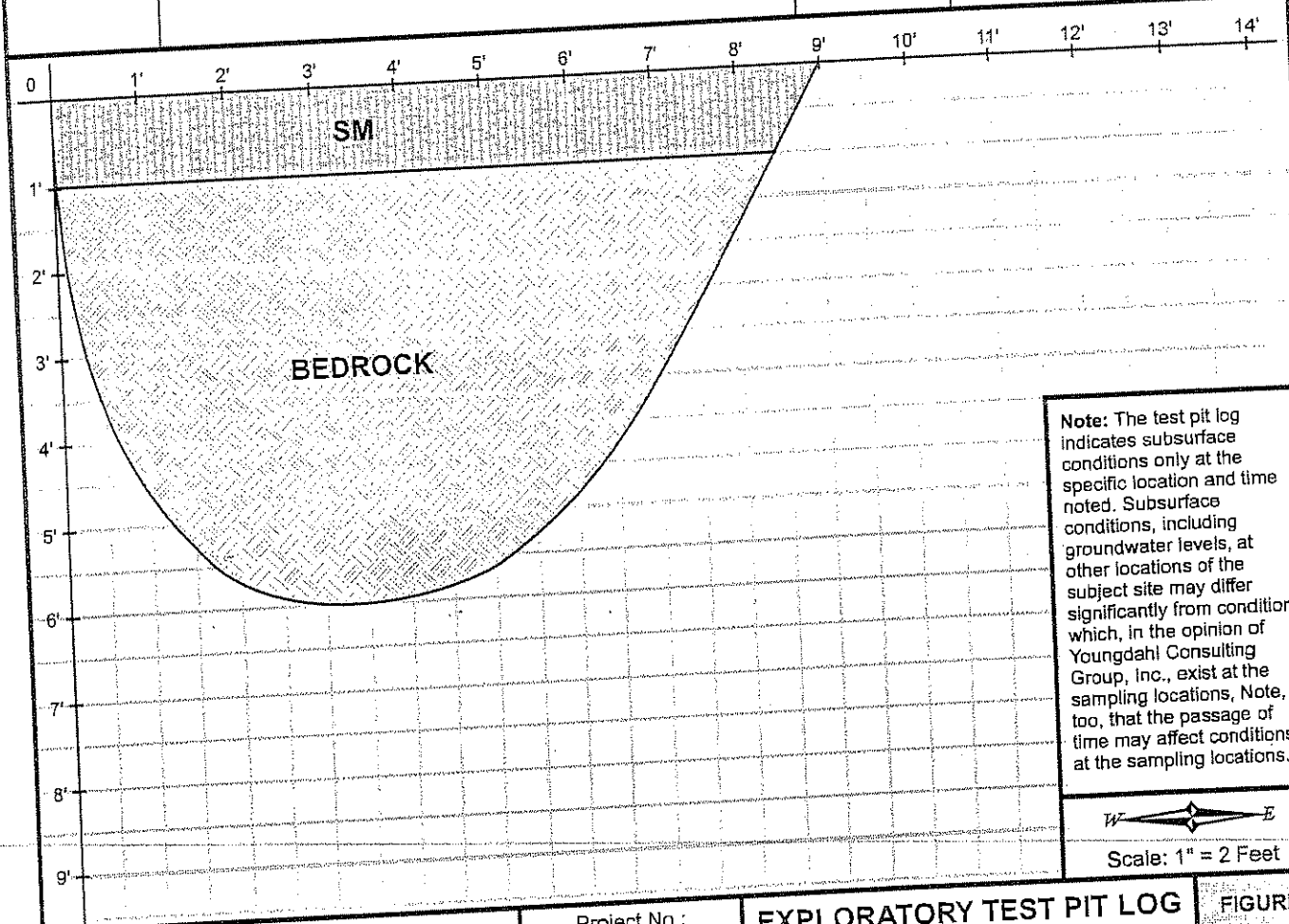

Note: The test pit log indicates subsurface conditions only at the specific location and time noted. Subsurface conditions, including groundwater levels, at other locations of the subject site may differ significantly from conditions which, in the opinion of Youngdahl Consulting Group, Inc., exist at the sampling locations. Note, too, that the passage of time may affect conditions at the sampling locations.

Scale: 1" = 2 Feet

| | | | |
|---|---------------------------|--|------------------------|
| YOUNGDAHL CONSULTING GROUP, INC. GEOTECHNICAL • ENVIRONMENTAL • MATERIALS TESTING | Project No.: 07145.000 | EXPLORATORY TEST PIT LOG White Rock & Scott Road 1400 Acre Property Folsom, California | FIGURE A-21 |
| | May 2007 | | |

| | | | |
|---|----------------------------|-------------------------------|-------------------------|
| Logged By: KEM | Date: 24 April 2007 | Elevation: | Pit No. TP-20 |
| Equipment: John Deere SG with 24" Bucket | | Pit Orientation: N - S | |

| Depth (Feet) | Geotechnical Description & Unified Soil Classification | Sample | Tests & Comments |
|--------------|---|--------|------------------|
| @ 0 - 1' | Red brown sandy SILT (ML) with trace gravel, medium stiff, slightly moist, with small roots | | NOA: 0' - 2.5' |
| @ 1' - 2.5' | Gray brown metasandstone BEDROCK , moderately weathered, very indurated, moderately developed fracturing, fractures closed to open to 1/8" with soil filling, slightly moist | | |
| | Test pit terminated at 2.5' (practical refusal) No free groundwater encountered No caving noted | | |

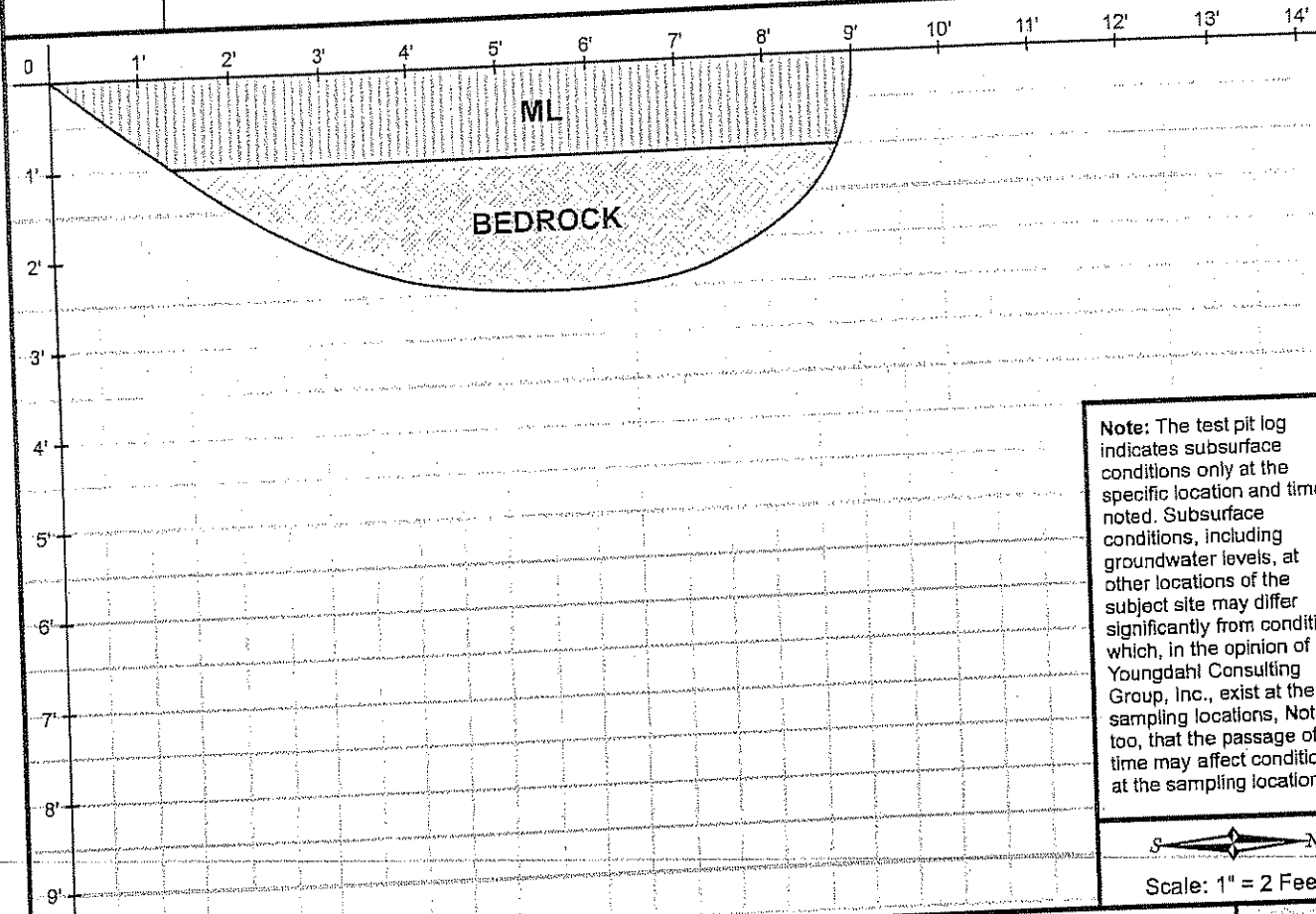

Note: The test pit log indicates subsurface conditions only at the specific location and time noted. Subsurface conditions, including groundwater levels, at other locations of the subject site may differ significantly from conditions which, in the opinion of Youngdahl Consulting Group, Inc., exist at the sampling locations. Note, too, that the passage of time may affect conditions at the sampling locations.

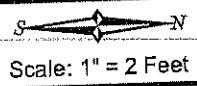

| | | | |
|---|---------------------------|--|--------------------------------------|
| <p>YOUNGDAHL CONSULTING GROUP, INC. GEOTECHNICAL • ENVIRONMENTAL • MATERIALS TESTING</p> | Project No.: 07145.000 | <p>EXPLORATORY TEST PIT LOG White Rock & Scott Road 1400 Acre Property Folsom, California</p> | <p>FIGURE A-22</p> |
| | May 2007 | | |

| | | | |
|--|---------------------|------------------------|-------------------------|
| Logged By: KEM | Date: 24 April 2007 | Elevation: | Pit No. TP-21 |
| Equipment: John Deere SG with 24" Bucket | | Pit Orientation: W - E | |

| Depth (Feet) | Geotechnical Description & Unified Soil Classification | Sample | Tests & Comments |
|--------------|--|--------|------------------|
| @ 0 - 1' | Light brown silty SAND (SM) with trace gravel, loose, slightly moist, with small roots | | NOA: 0' - 5.5' |
| @ 1' - 5.5' | Gray metasedimentary BEDROCK (SLATE), highly weathered, indurated, moderately developed fracturing, fractures closed to open to 1/4" with soil filling, slightly moist | | |
| | Test pit terminated at 5.5' (practical refusal) No free groundwater encountered No caving noted | | |

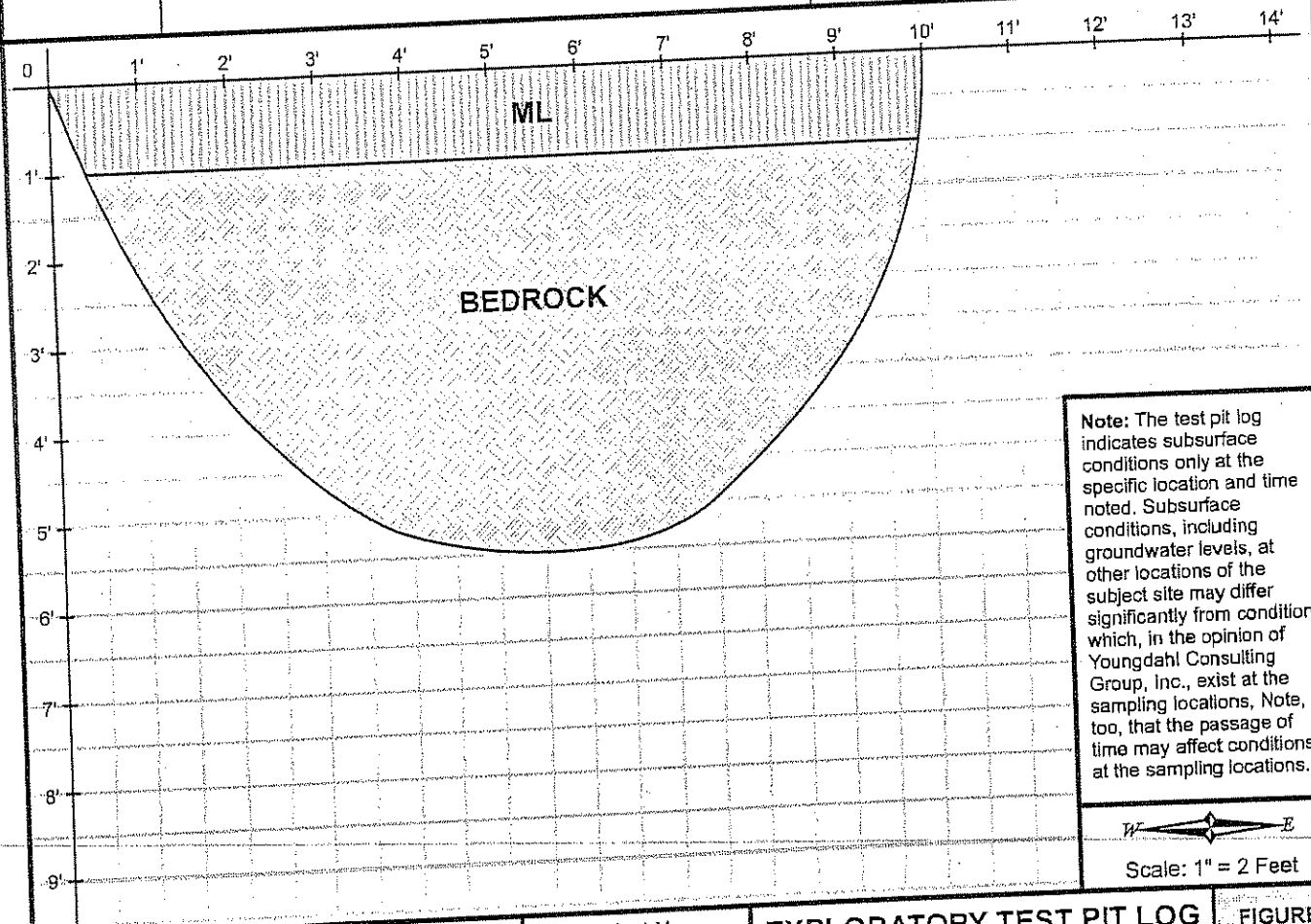

Note: The test pit log indicates subsurface conditions only at the specific location and time noted. Subsurface conditions, including groundwater levels, at other locations of the subject site may differ significantly from conditions which, in the opinion of Youngdahl Consulting Group, Inc., exist at the sampling locations. Note, too, that the passage of time may affect conditions at the sampling locations.

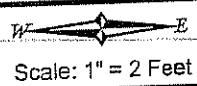

YOUNGDAHL
CONSULTING GROUP, INC.
GEOTECHNICAL • ENVIRONMENTAL • MATERIALS TESTING

Project No.: 07145.000
May 2007

EXPLORATORY TEST PIT LOG
White Rock & Scott Road
1400 Acre Property
Folsom, California

FIGURE
A-23

| | | | |
|---|----------------------------|-------------------------------|-------------------------|
| Logged By: KEM | Date: 25 April 2007 | Elevation: | Pit No. TP-22 |
| Equipment: John Deere SG with 24" Bucket | | Pit Orientation: W - E | |

| Depth (Feet) | Geotechnical Description & Unified Soil Classification | Sample | Tests & Comments |
|--------------|--|--------|------------------|
| @ 0 - 1' | Brown silty SAND (SM) with trace gravel, loose, slightly moist, with small roots | | NOA: 0' - 2.5' |
| @ 1' - 2.5' | Gray metasedimentary BEDROCK (SLATE) , highly weathered, indurated, moderately developed fracturing, fractures closed to open to 1/4" with soil filling, slightly moist | | |
| | Test pit terminated at 2.5' (practical refusal) No free groundwater encountered No caving noted | | |

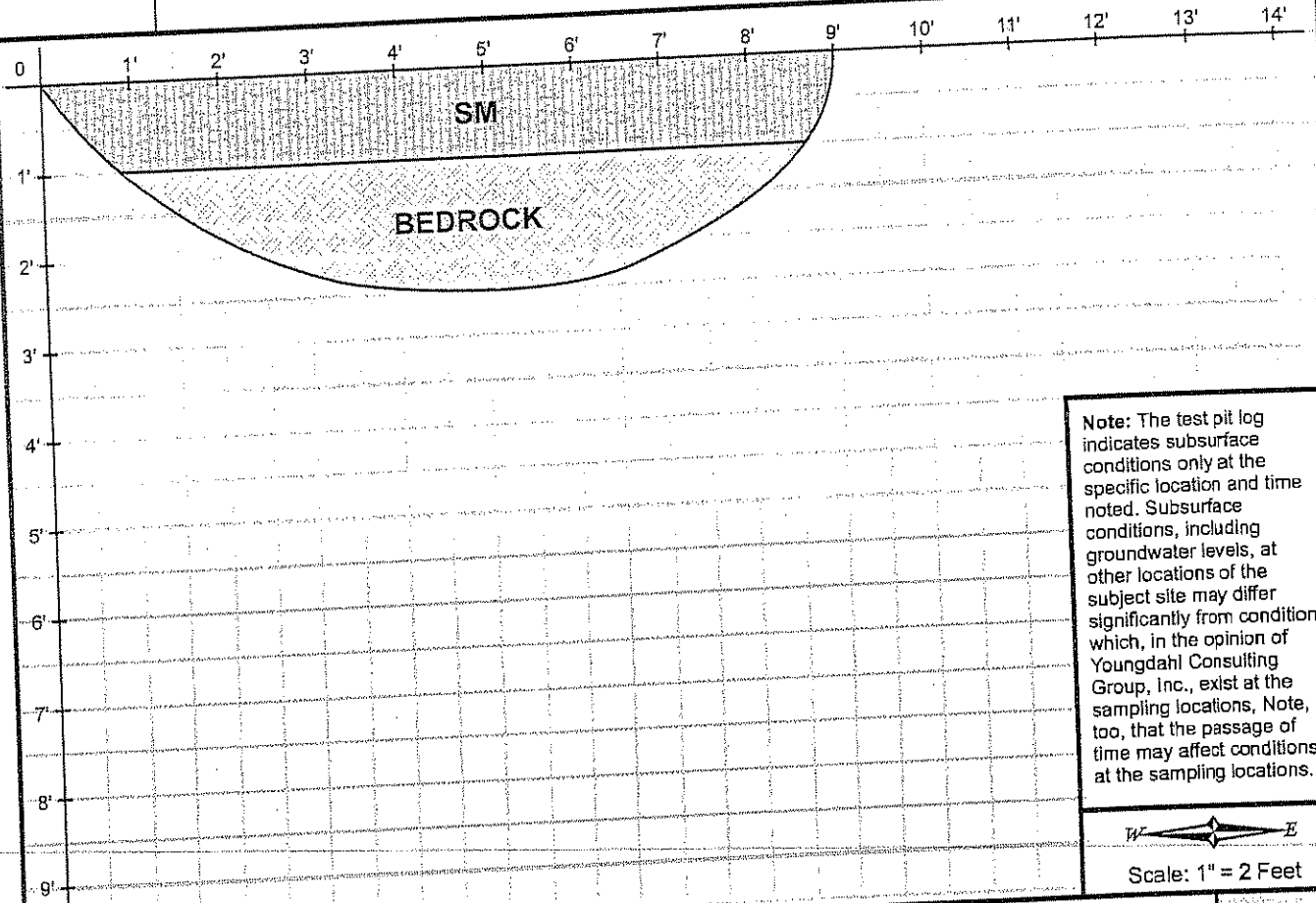

Note: The test pit log indicates subsurface conditions only at the specific location and time noted. Subsurface conditions, including groundwater levels, at other locations of the subject site may differ significantly from conditions which, in the opinion of Youngdahl Consulting Group, Inc., exist at the sampling locations. Note, too, that the passage of time may affect conditions at the sampling locations.

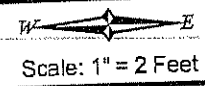

| | | | |
|--|---------------------------|--|------------------------------|
| | Project No.: 07145.000 | EXPLORATORY TEST PIT LOG White Rock & Scott Road 1400 Acre Property Folsom, California | FIGURE A-24 |
| | May 2007 | | |

| Logged By: KEM | | Date: 25 April 2007 | Elevation: | Pit No. TP-23 |
|---|--|----------------------------|-------------------------------|-------------------------|
| Equipment: John Deere SG with 24" Bucket | | | Pit Orientation: N - S | |
| Depth (Feet) | Geotechnical Description & Unified Soil Classification | Sample | Tests & Comments | |
| @ 0 - 0.5' | Light brown sandy SILT (ML) with trace gravel, medium stiff, slightly moist, with small roots | | NOA: 0' - 5.5' | |
| @ 0.5' - 5.5' | Light gray metasedimentary BEDROCK (SLATE) , highly weathered, indurated, moderately developed fracturing, fractures closed to open to 1/4" with soil filling, slightly moist | | | |
| | Test pit terminated at 5.5' (practical refusal) No free groundwater encountered No caving noted | | | |

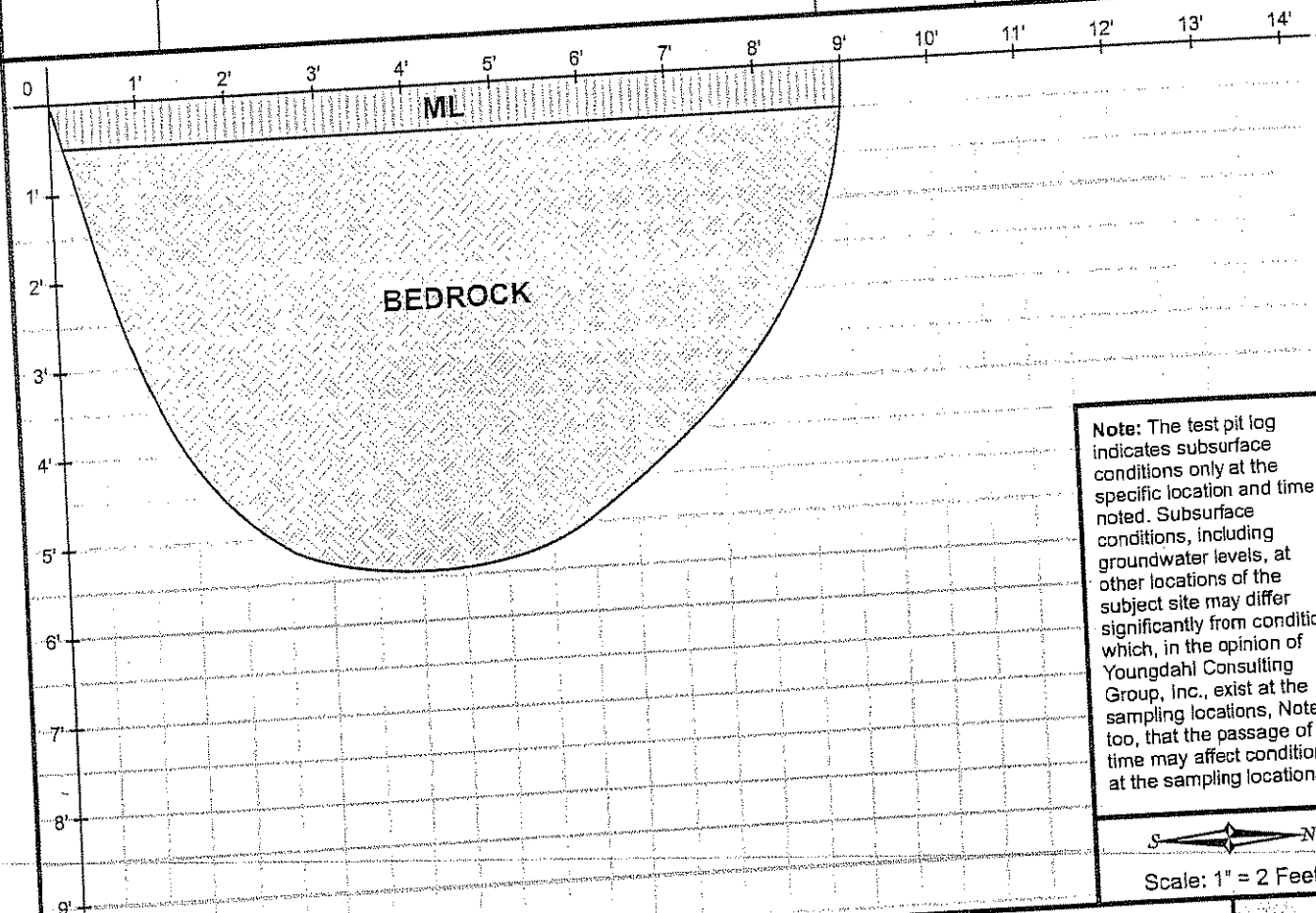

Note: The test pit log indicates subsurface conditions only at the specific location and time noted. Subsurface conditions, including groundwater levels, at other locations of the subject site may differ significantly from conditions which, in the opinion of Youngdahl Consulting Group, Inc., exist at the sampling locations. Note, too, that the passage of time may affect conditions at the sampling locations.

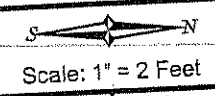

Project No.:
07145.000
May 2007

EXPLORATORY TEST PIT LOG
White Rock & Scott Road
1400 Acre Property
Folsom, California

FIGURE
A-25

| Logged By: KEM | | Date: 25 April 2007 | Elevation: | Pit No. TP-24 |
|---|--|-------------------------------|------------------|-------------------------|
| Equipment: John Deere SG with 24" Bucket | | Pit Orientation: W - E | | |
| Depth (Feet) | Geotechnical Description & Unified Soil Classification | Sample | Tests & Comments | |
| @ 0 - 1' | Yellow brown silty SAND (SM) with trace gravel, loose, slightly moist, with small roots | | NOA: 0' - 9' | |
| @ 1' - 9' | Gray brown metasedimentary BEDROCK (SLATE) , completely weathered, weakly indurated, poorly developed fracturing, fractures open to 1/2" with clay filling, thin interbeds of metasandstone | | | |
| | Test pit terminated at 9' (practical refusal) No free groundwater encountered No caving noted | | | |

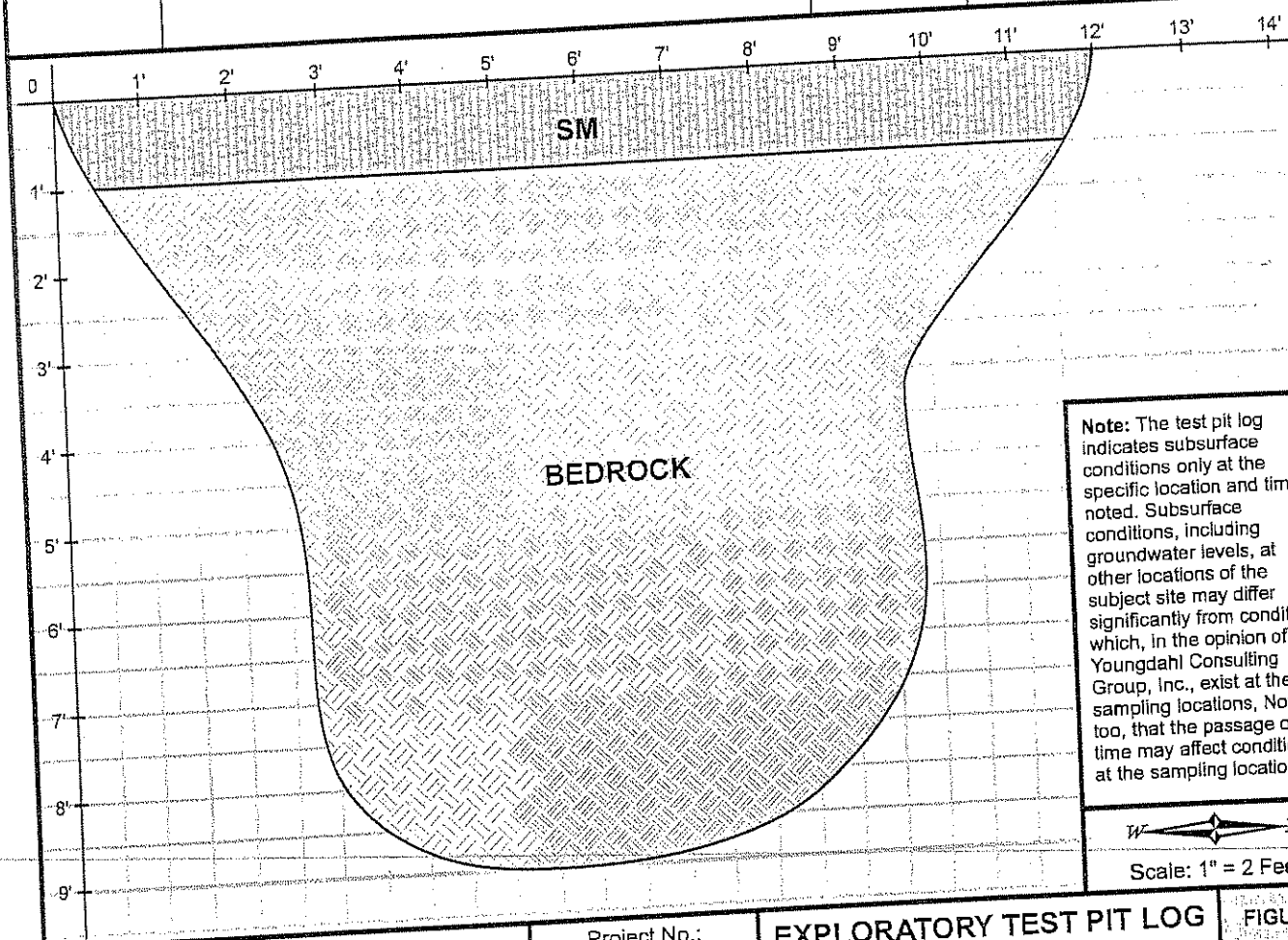

W ————— E
Scale: 1" = 2 Feet

| | | | |
|---|---------------------------|--|--------------------------------------|
| <p>YOUNGDAHL CONSULTING GROUP, INC. GEOTECHNICAL • ENVIRONMENTAL • MATERIALS TESTING</p> | Project No.: 07145.000 | <p>EXPLORATORY TEST PIT LOG White Rock & Scott Road 1400 Acre Property Folsom, California</p> | <p>FIGURE A-26</p> |
| | May 2007 | | |

| | | | |
|--|---------------------|------------------------|-------------------------|
| Logged By: KEM | Date: 25 April 2007 | Elevation: | Pit No. TP-25 |
| Equipment: John Deere SG with 24" Bucket | | Pit Orientation: S - N | |

| Depth (Feet) | Geotechnical Description & Unified Soil Classification | Sample | Tests & Comments |
|--------------|--|--------|------------------|
| @ 0 - 1' | Brown silty SAND (SM) with trace gravel, loose, slightly moist, with small roots | | NOA: 0' - 4' |
| @ 1' - 4' | Gray metasedimentary BEDROCK (SLATE), highly weathered, indurated, moderately developed fracturing, fractures closed to open with soil filling, slightly moist | | |
| | Test pit terminated at 4' (practical refusal) No free groundwater encountered No caving noted | | |

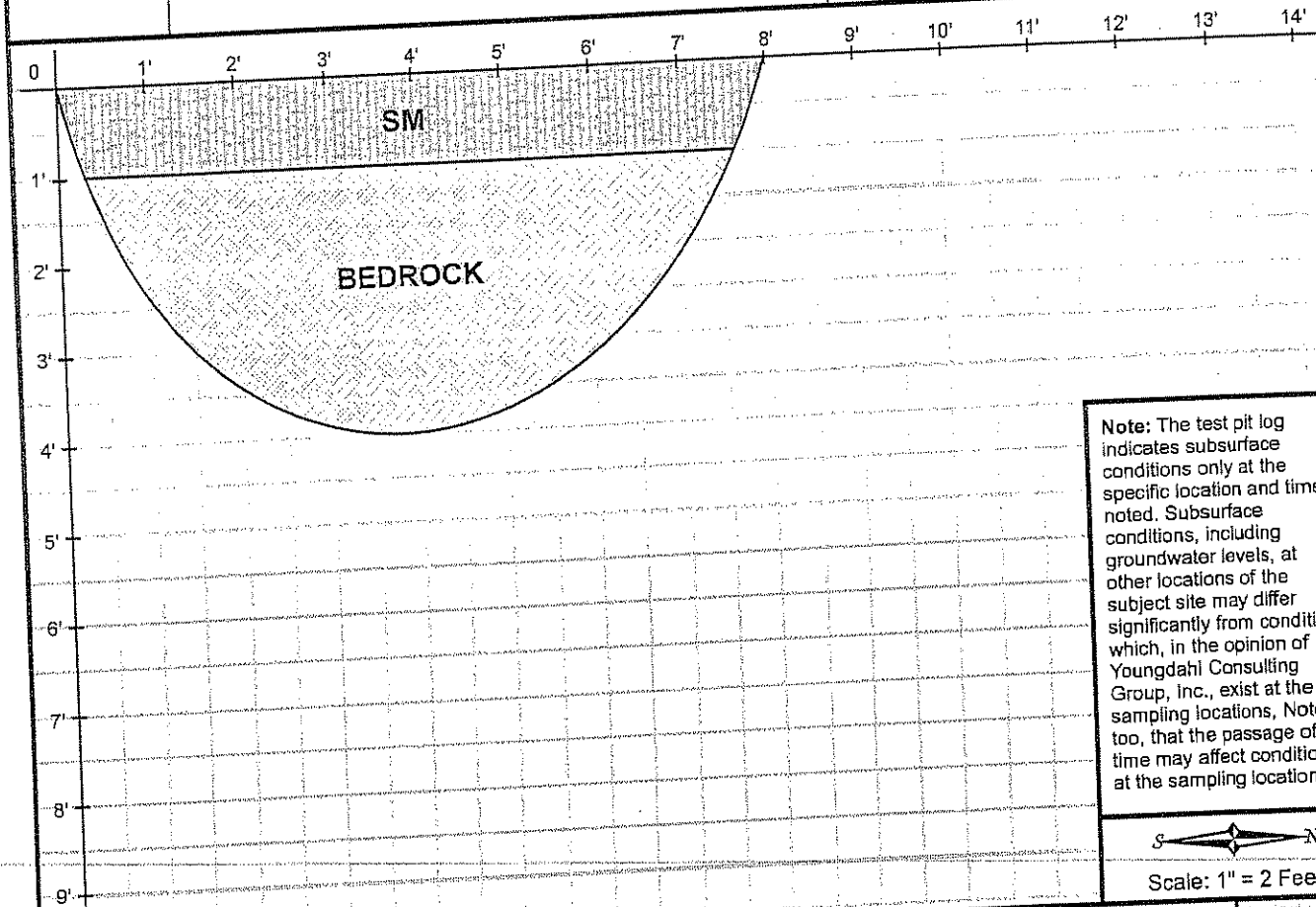

Note: The test pit log indicates subsurface conditions only at the specific location and time noted. Subsurface conditions, including groundwater levels, at other locations of the subject site may differ significantly from conditions which, in the opinion of Youngdahl Consulting Group, Inc., exist at the sampling locations. Note, too, that the passage of time may affect conditions at the sampling locations.

 Scale: 1" = 2 Feet

| | | | |
|---|------------------------|--|------------------------------|
|  YOUNGDAHL CONSULTING GROUP, INC. <small>GEOTECHNICAL • ENVIRONMENTAL • MATERIALS TESTING</small> | Project No.: 07145.000 | EXPLORATORY TEST PIT LOG White Rock & Scott Road 1400 Acre Property Folsom, California | FIGURE A-27 |
| | May 2007 | | |

| | | | |
|--|---------------------|------------------------|-------------------------|
| Logged By: KEM | Date: 25 April 2007 | Elevation: | Pit No. TP-26 |
| Equipment: John Deere SG with 24" Bucket | | Pit Orientation: S - N | |

| Depth (Feet) | Geotechnical Description & Unified Soil Classification | Sample | Tests & Comments |
|--------------|--|--------|--|
| @ 0 - 1' | Dark brown silty SAND (SM) with trace gravel, loose, slightly moist, with small roots | | NOA: 0' - 6' Geothermal Alteration Zone (Low Grade) |
| @ 1' - 6' | Yellow brown metasandstone BEDROCK , highly weathered, indurated, poorly developed foliation, moderately developed fracturing, foliation and fracturing closed with black staining to open 1/4" with soil and clay lining, slightly moist | | |
| | Test pit terminated at 6' (practical refusal) No free groundwater encountered No caving noted | | |

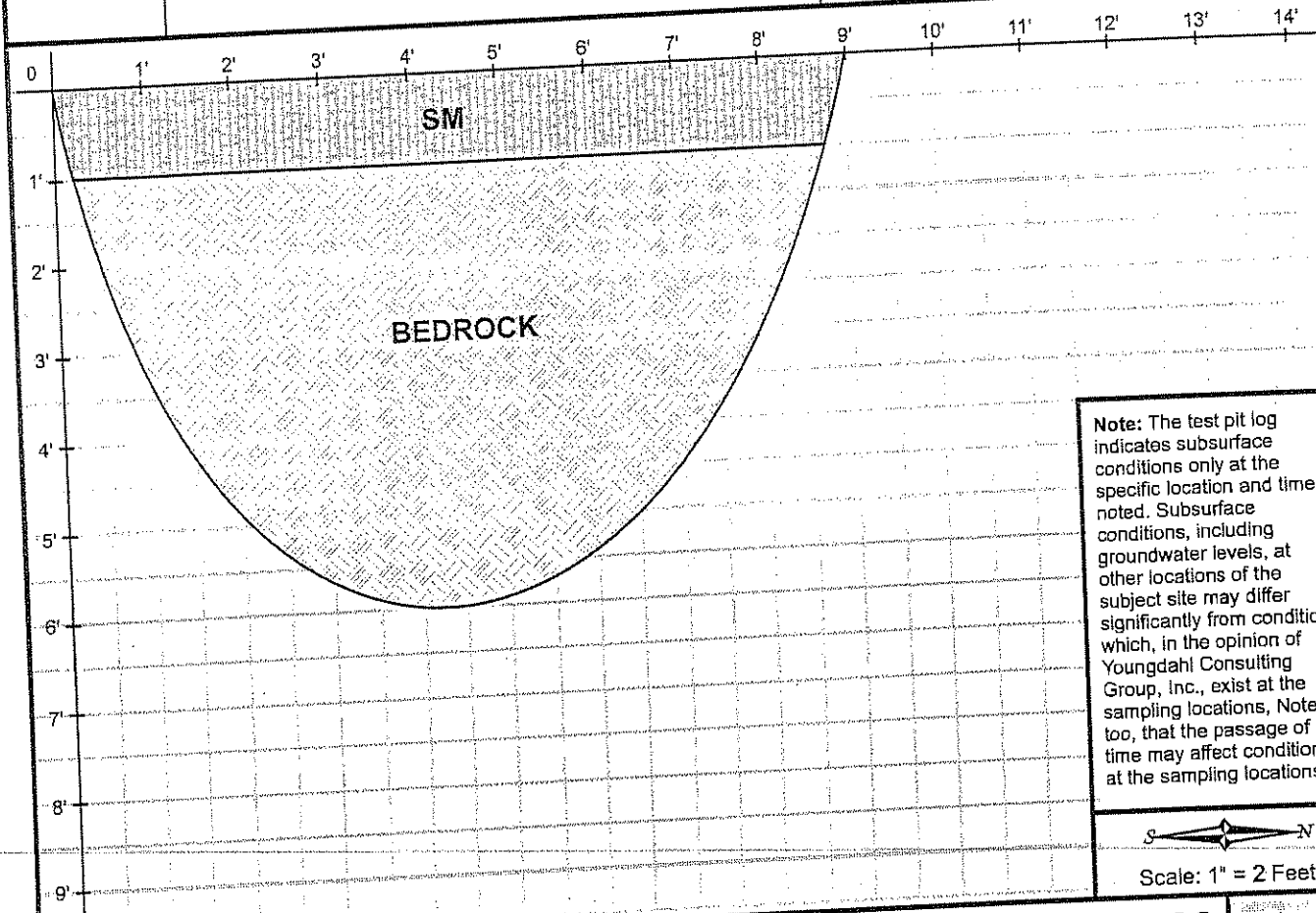

| | | | |
|--|---------------------------|--|------------------------------|
| YOUNGDAHL CONSULTING GROUP, INC. GEOTECHNICAL • ENVIRONMENTAL • MATERIALS TESTING | Project No.: 07145.000 | EXPLORATORY TEST PIT LOG White Rock & Scott Road 1400 Acre Property Folsom, California | FIGURE A-28 |
| | May 2007 | | |

| | | | |
|---|----------------------------|-------------------------------|-------------------------|
| Logged By: KEM | Date: 25 April 2007 | Elevation: | Pit No. TP-27 |
| Equipment: John Deere SG with 24" Bucket | | Pit Orientation: N - S | |

| Depth (Feet) | Geotechnical Description & Unified Soil Classification | Sample | Tests & Comments |
|--------------|---|--------|------------------|
| @ 0 - 0.5' | Light red brown sandy SILT (ML) with trace gravel, medium stiff, slightly moist, with small roots | | NOA: 0' - 5' |
| @ 0.5' - 5' | Light gray metasandstone BEDROCK , highly weathered, indurated, moderately developed fracturing, fractures closed to open 1/4" with soil filling, slightly moist | | |
| | Test pit terminated at 5' (practical refusal) No free groundwater encountered No caving noted | | |

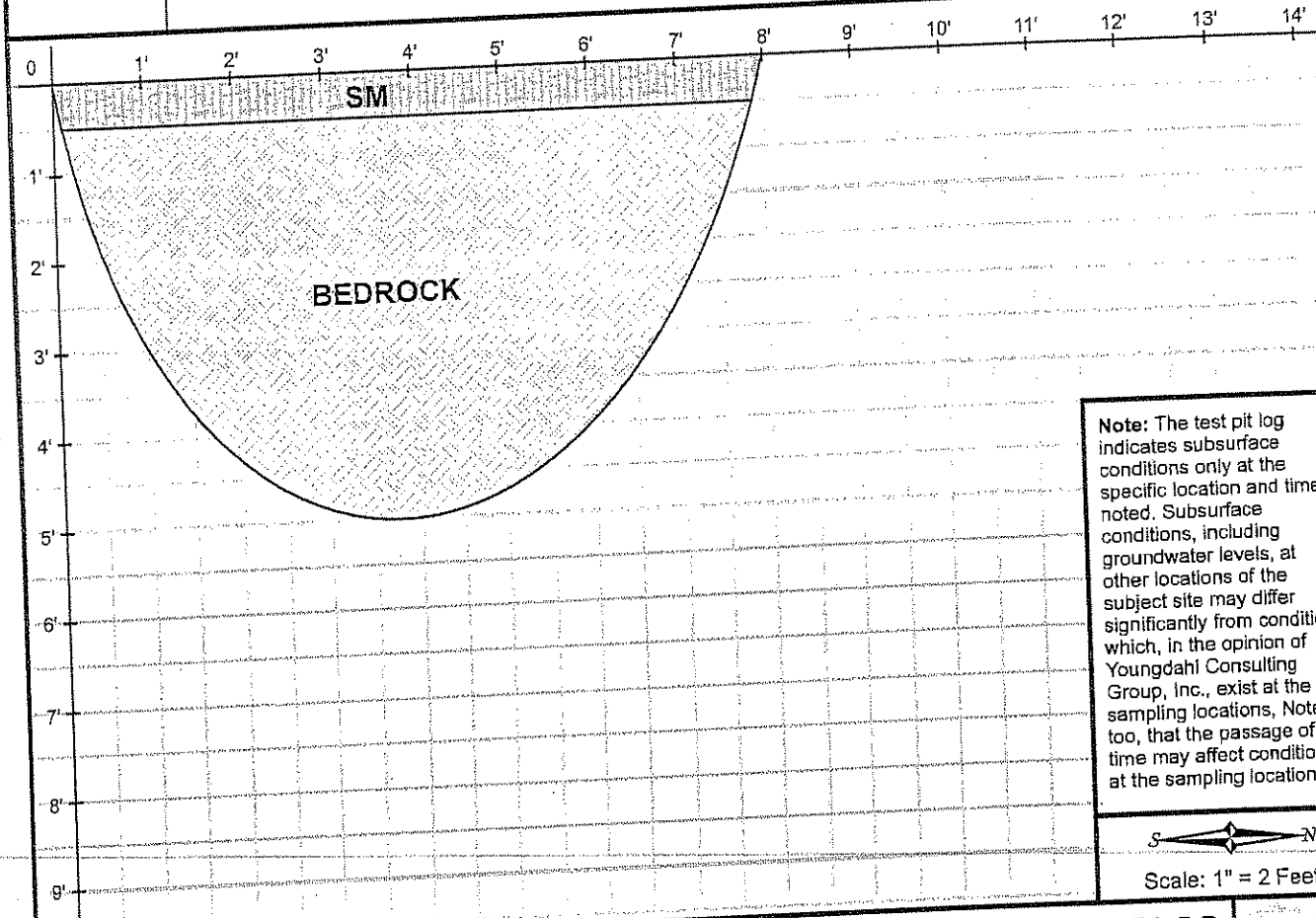

| | | | |
|---|---------------------------|--|------------------------------|
| YOUNGDAHL CONSULTING GROUP, INC. <small>GEOTECHNICAL • ENVIRONMENTAL • MATERIALS TESTING</small> | Project No.: 07145.000 | EXPLORATORY TEST PIT LOG White Rock & Scott Road 1400 Acre Property Folsom, California | FIGURE A-29 |
| | May 2007 | | |

| | | | |
|---|----------------------------|-------------------------------|-------------------------|
| Logged By: KEM | Date: 25 April 2007 | Elevation: | Pit No. TP-28 |
| Equipment: John Deere SG with 24" Bucket | | Pit Orientation: W - E | |

| Depth (Feet) | Geotechnical Description & Unified Soil Classification | Sample | Tests & Comments |
|--------------|---|--------|--|
| @ 0 - 1.5' | Red brown silty SAND (SM) with trace gravel, loose, slightly moist, with small roots | | NOA: 0' - 4.5' Geothermal Alteration Zone (Low Grade) |
| @ 1.5' - 4' | Dark olive metasandstone BEDROCK , highly weathered, weakly indurated, poorly developed fracturing, slightly moist | | |
| @ 4' - 4.5' | <i>Grades moderately indurated</i> | | |
| | Test pit terminated at 4.5' (practical refusal) No free groundwater encountered No caving noted | | |

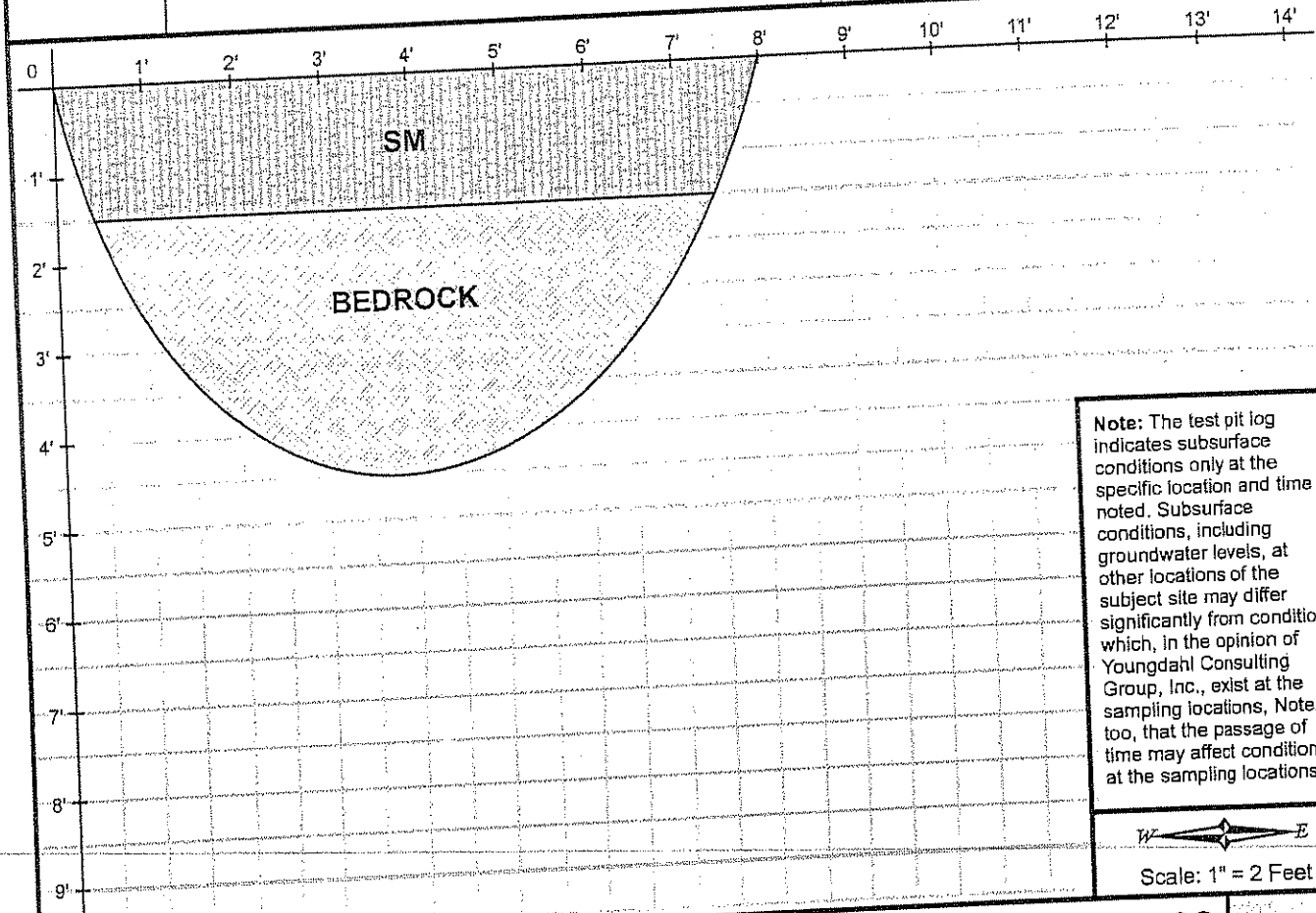

| | | | |
|---|---------------------------|--|-------------------------------|
| <p>YOUNGDAHL CONSULTING GROUP, INC. GEOTECHNICAL • ENVIRONMENTAL • MATERIALS TESTING</p> | Project No.: 07145.000 | <p>EXPLORATORY TEST PIT LOG White Rock & Scott Road 1400 Acre Property Folsom, California</p> | <p>FIGURE A-30</p> |
| | May 2007 | | |

| | | | |
|--|---------------------|------------------------|-------------------------|
| Logged By: KEM | Date: 25 April 2007 | Elevation: | Pit No. TP-29 |
| Equipment: John Deere SG with 24" Bucket | | Pit Orientation: W - E | |

| Depth (Feet) | Geotechnical Description & Unified Soil Classification | Sample | Tests & Comments |
|---------------|--|--------|------------------|
| @ 0 - 0.5' | Light brown sandy SILT (ML) with trace gravel, medium stiff, slightly moist, with small roots | | NOA: 0' - 4.5' |
| @ 0.5' - 4.5' | Gray metasedimentary BEDROCK (SLATE) , highly weathered, indurated, moderately developed fracturing, fractures closed to open with soil filling, slightly moist | | |
| | Test pit terminated at 4.5' (practical refusal) No free groundwater encountered No caving noted | | |

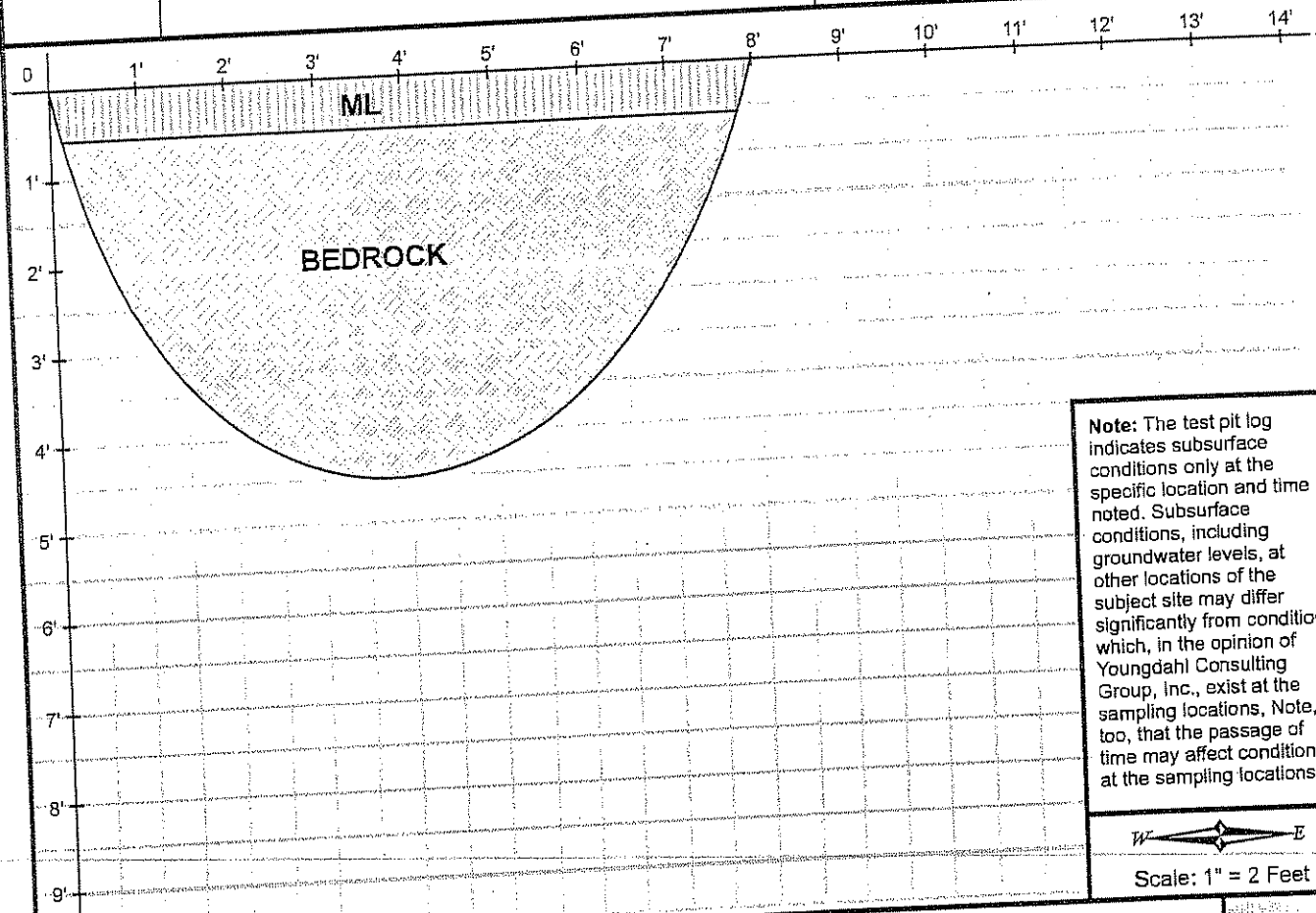

Note: The test pit log indicates subsurface conditions only at the specific location and time noted. Subsurface conditions, including groundwater levels, at other locations of the subject site may differ significantly from conditions which, in the opinion of Youngdahl Consulting Group, inc., exist at the sampling locations. Note, too, that the passage of time may affect conditions at the sampling locations.

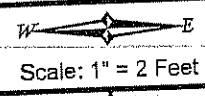

| | | | |
|--|------------------------|--|--------------------|
| | Project No.: 07145.000 | EXPLORATORY TEST PIT LOG White Rock & Scott Road 1400 Acre Property Folsom, California | FIGURE A-31 |
| | May 2007 | | |

| | | | |
|--|---------------------|------------------------|-------------------------|
| Logged By: KEM | Date: 25 April 2007 | Elevation: | Pit No. TP-30 |
| Equipment: John Deere SG with 24" Bucket | | Pit Orientation: W - E | |

| Depth (Feet) | Geotechnical Description & Unified Soil Classification | Sample | Tests & Comments |
|---------------|---|--------|------------------|
| @ 0 - 1.5' | Yellow brown silty SAND (SM) with trace gravel, loose, slightly moist, with small roots | | NOA: 0' - 5.5' |
| @ 1.5' - 3.5' | <i>Grades medium dense</i> | | |
| @ 3.5' - 4.5' | <i>Grades with coarse gravel and few cobbles</i> | | |
| @ 4.5' - 5.5' | Gray metasedimentary BEDROCK (SLATE) , highly weathered, indurated, moderately developed fracturing, fractures closed to open 1/8" with soil filling, slightly moist | | |
| | Test pit terminated at 5.5' (practical refusal) No free groundwater encountered No caving noted | | |

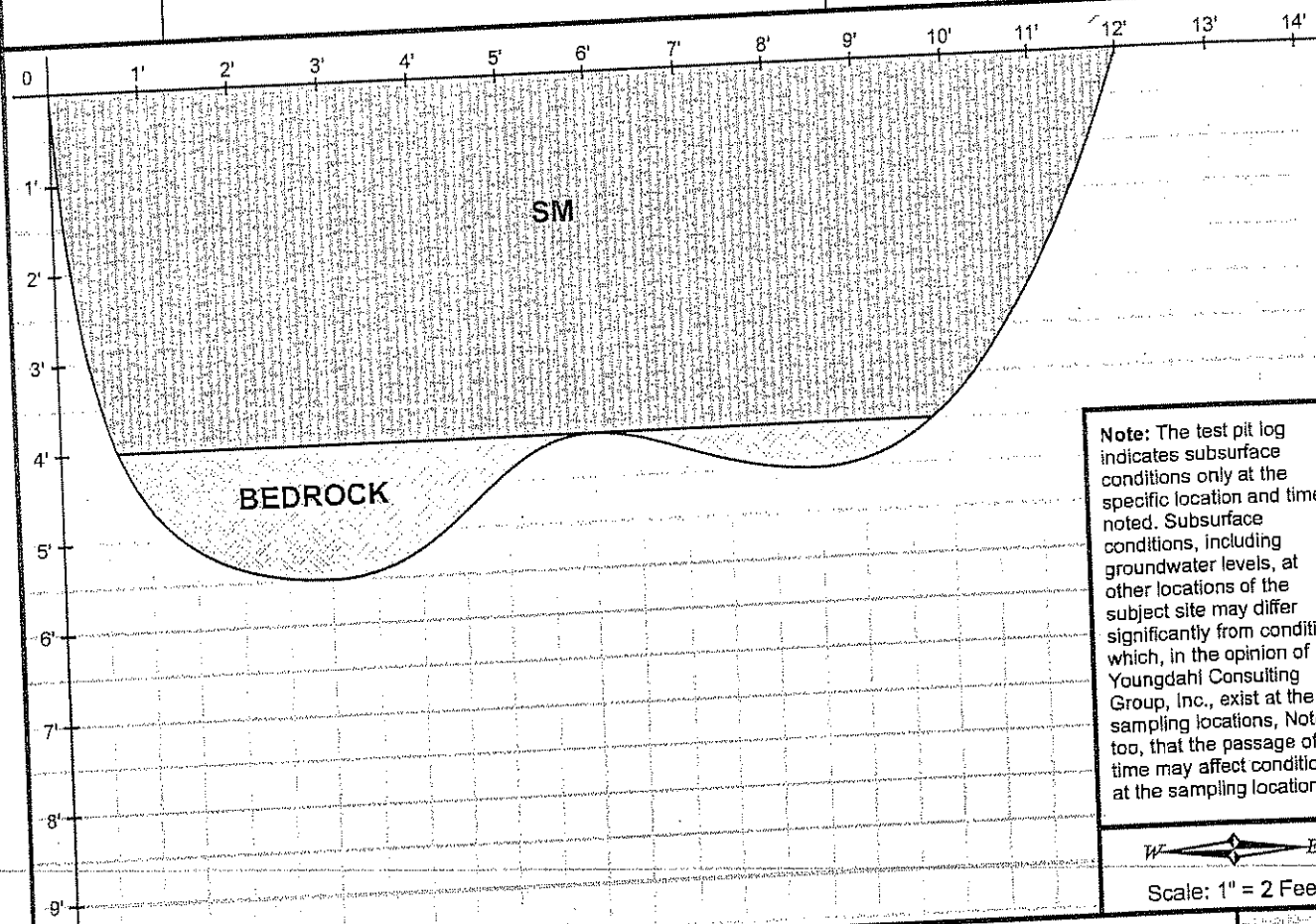

Note: The test pit log indicates subsurface conditions only at the specific location and time noted. Subsurface conditions, including groundwater levels, at other locations of the subject site may differ significantly from conditions which, in the opinion of Youngdahl Consulting Group, Inc., exist at the sampling locations. Note, too, that the passage of time may affect conditions at the sampling locations.

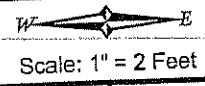

| | | | |
|---|------------------------|--|------------------------------|
| <p>YOUNGDAHL CONSULTING GROUP, INC. GEOTECHNICAL • ENVIRONMENTAL • MATERIALS TESTING</p> | Project No.: 07145.000 | EXPLORATORY TEST PIT LOG White Rock & Scott Road 1400 Acre Property Folsom, California | FIGURE A-32 |
| | May 2007 | | |

| | | | |
|--|---------------------|------------------------|-------------------------|
| Logged By: KEM | Date: 25 April 2007 | Elevation: | Pit No. TP-31 |
| Equipment: John Deere SG with 24" Bucket | | Pit Orientation: S - N | |

| Depth (Feet) | Geotechnical Description & Unified Soil Classification | Sample | Tests & Comments |
|--------------|---|--------|------------------|
| @ 0 - 0.5' | Very light brown sandy SILT (ML) with trace gravel, medium stiff, slightly moist, with small roots | | NOA: 0' - 5' |
| @ 0.5' - 5' | Light gray brown metasedimentary BEDROCK (SLATE) , highly weathered, indurated, well developed fracturing, fractures closed to open 1/4" with soil filling, slightly moist | | |
| | Test pit terminated at 5' (practical refusal) No free groundwater encountered No caving noted | | |

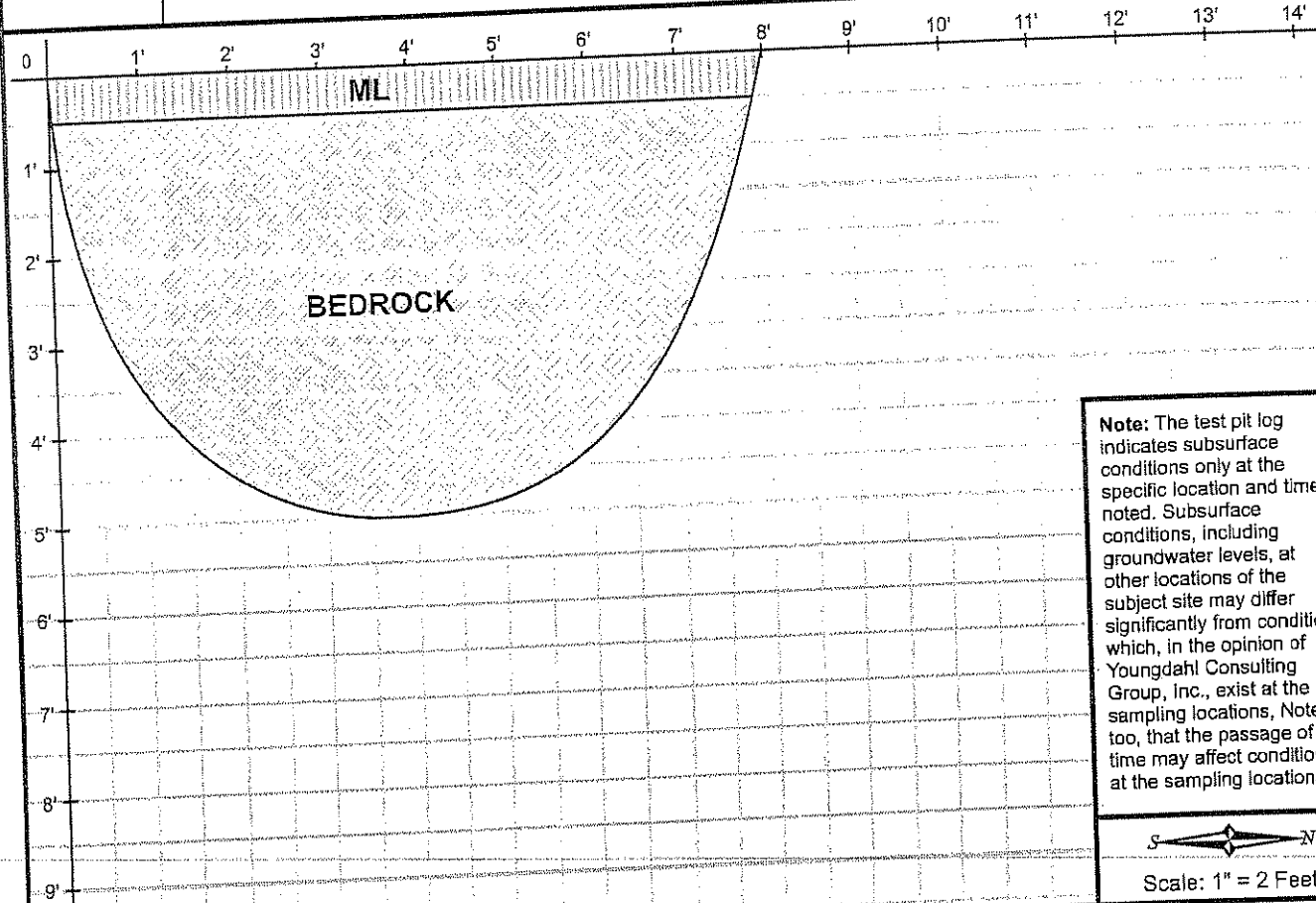

| | | | |
|---|------------------------|--|-------------------------------|
| <p>YOUNGDAHL CONSULTING GROUP, INC. GEOTECHNICAL • ENVIRONMENTAL • MATERIALS TESTING</p> | Project No.: 07145.000 | <p>EXPLORATORY TEST PIT LOG White Rock & Scott Road 1400 Acre Property Folsom, California</p> | <p>FIGURE A-33</p> |
| | May 2007 | | |

| UNIFIED SOIL CLASSIFICATION SYSTEMS | | | MAJOR DIVISION | SYMBOLS | TYPICAL NAMES | |
|---|--------------------------------|---|------------------------------------|---|--|--|
| COARSE GRAINED SOILS Over 50% > #200 sieve | GRAVELS Over 50% > #4 sieve | Clean GRAVELS With Little Or No Fines | GW | | Well graded GRAVELS, GRAVEL-SAND mixtures | |
| | | GRAVELS With Over 12% Fines | GP | | Poorly graded GRAVELS, GRAVEL-SAND mixtures | |
| | | | GM | | Silty GRAVELS, poorly graded GRAVEL-SAND-SILT mixtures | |
| | | GC | | Clayey GRAVELS, poorly graded GRAVEL-SAND-CLAY mixtures | | |
| | SANDS Over 50% < #4 sieve | Clean SANDS With Little Or No Fines | SW | | Well graded SANDS, gravelly SANDS | |
| | | SANDS With Over 12% Fines | SP | | Poorly graded SANDS, gravelly SANDS | |
| | | | SM | | Silty SANDS, poorly graded SAND-SILT mixtures | |
| | | SC | | Clayey SANDS, poorly graded SAND-CLAY mixtures | | |
| | | FINE GRAINED SOILS Over 50% < #200 sieve | SILTS & CLAYS Liquid Limit < 60 | ML | | Inorganic SILTS, silty or clayey fine SANDS, or clayey SILTS with plasticity |
| | | | | CL | | Inorganic CLAYS of low to medium plasticity, gravelly, sandy, or silty CLAYS, lean CLAYS |
| OL | | | | Organic CLAYS and organic silty CLAYS of low plasticity | | |
| SILTS & CLAYS Liquid Limit > 50 | MH | | | Inorganic SILTS, micaceous or diamicaceous fine sandy or silty soils, elastic SILTS | | |
| | CH | | | Inorganic CLAYS of high plasticity, fat CLAYS | | |
| | OH | | | Organic CLAYS of medium to high plasticity, organic SILTS | | |
| | PT | | | PEAT & other highly organic soils | | |
| HIGHLY ORGANIC CLAYS | | | | | | |

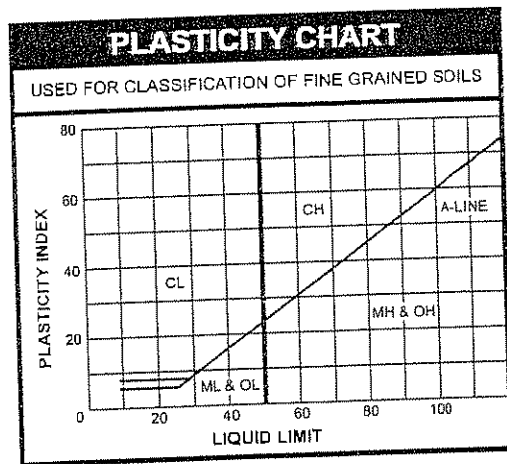

SAMPLE DRIVING RECORD

| BLOWS PER FOOT | DESCRIPTION |
|----------------|---|
| 25 | 25 Blows drove sampler 12 inches, after initial 6 inches of seating |
| 50/7" | 50 Blows drove sampler 7 inches, after initial 6 inches of seating |
| 50/3" | 50 Blows drove sampler 3 inches during or after initial 6 inches of seating |

Note: To avoid damage to sampling tools, driving is limited to 50 blows per 5 inches during or after seating interval.

SOIL GRAIN SIZE

| U.S. STANDARD SIEVE | 6" | 3" | 3/4" | 4 | 10 | 40 | 200 | | |
|--------------------------------|---------|--------|--------|------|--------|--------|-------|-------|------|
| | BOULDER | COBBLE | GRAVEL | | SAND | | | SILT | CLAY |
| | | | COARSE | FINE | COARSE | MEDIUM | FINE | | |
| SOIL GRAIN SIZE IN MILLIMETERS | 150 | 75 | 19 | 4.75 | 2.0 | .425 | 0.075 | 0.002 | |

| KEY TO PIT & BORING SYMBOLS | KEY TO PIT & BORING SYMBOLS |
|-----------------------------|---------------------------------------|
| | Standard Penetration test |
| | 2.5" O.D. Modified California Sampler |
| | 3" O.D. Modified California Sampler |
| | Shelby Tube Sampler |
| | 2.5" Hand Driven Liner |
| | Bulk Sample |
| | Water Level At Time Of Drilling |
| | Water Level After Time Of Drilling |
| | Perched Water |
| | Joint |
| | Foliation |
| | Water Seepage |
| NFWE | No Free Water Encountered |
| FWE | Free Water Encountered |
| REF | Sampling Refusal |
| DD | Dry Density (pcf) |
| MC | Moisture Content (%) |
| LL | Liquid Limit |
| PI | Plasticity Index |
| PP | Pocket Penetrometer |
| UCC | Unconfined Compression (ASTM D2166) |
| TVS | Pocket Torvane Shear |
| EI | Expansion Index (ASTM D4829) |
| Su | Undrained Shear Strength |

Soil Survey Of Sacramento County, California

White Rock Road / Scott Road 1400 Acre Development

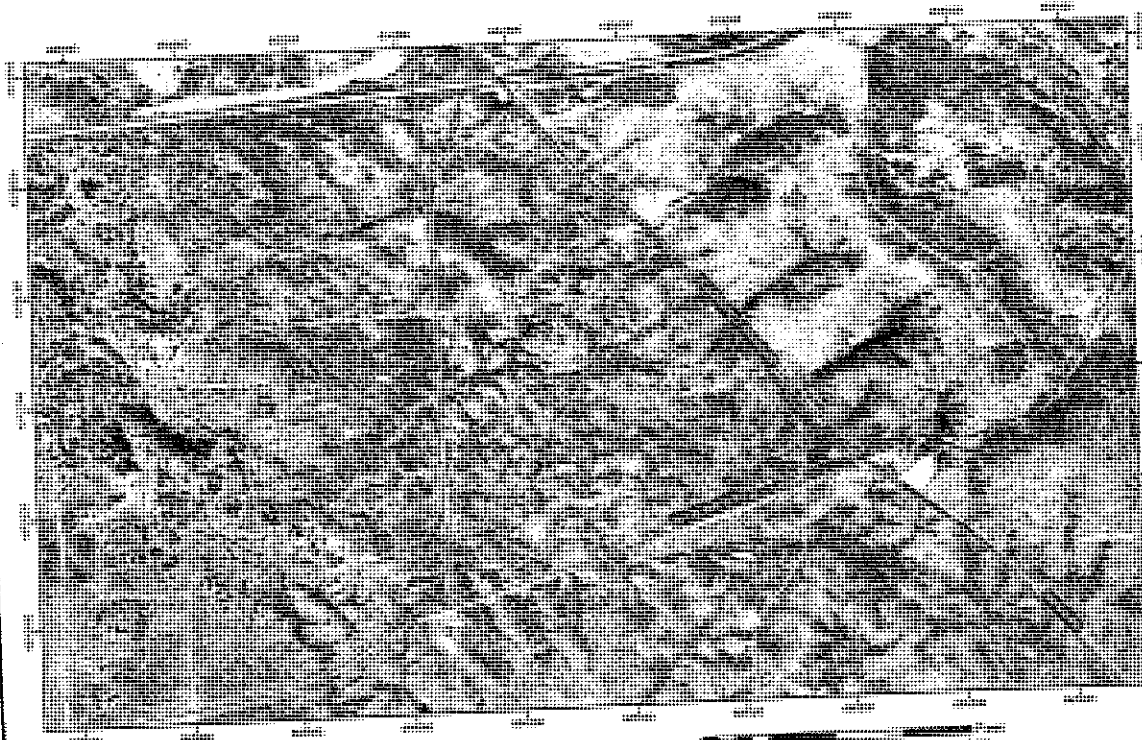

0 200 400 800 Meters

0 500 1,000 2,000 3,000 4,000 Meters

Map Unit Legend Summary

MAP LEGEND

- Soil Map Units
- Cities
- Detailed Counties
- Detailed States
- Interstate Highways
- Roads
- Rails
- Water
- Hydrography
- Oceans
- Escarpment, bedrock
- Escarpment, non-bedrock
- Gully
- Loose
- Slope
- Blowout
- Borrow Pit
- Clay Spot
- Depression, closed
- Eroded Spot
- Gravel Pit
- Gravelly Spot
- Gully
- Lava Flow
- Landfill
- Marsh or Swamp
- Miscellaneous Water
- Rock Outcrop
- Saline Spot
- Sandy Spot
- Slide or Slip
- Sinkhole
- Sodic Spot
- Spill Area
- Stony Spot
- Very Stony Spot
- Perennial Water
- Wet Spot

Sacramento County, California

| Map Unit Symbol | Map Unit Name | Acres in AOI | Percent of AOI | Hydrologic Soil Group |
|-----------------|--|--------------|----------------|-----------------------|
| 107 | Argonaut-Auburn complex, 3 to 8 percent slopes | 322.3 | 24.4 | D |
| 109 | Auburn silt loam, 2 to 30 percent slopes | 0.5 | 0.0 | D |
| 110 | Auburn-Argonaut-Rock outcrop complex, 8 to 30 percent slopes | 305.7 | 23.4 | D |
| 257 | Whiterock loam, 3 to 30 percent slopes | 693.9 | 52.5 | D |

MAP INFORMATION

Source of Map: Natural Resources Conservation Service
 Web Soil Survey URL: <http://websoilsurvey.nrcs.usda.gov>

Coordinate System: UTM Zone 10
 Soil Survey Area: Sacramento County, California
 Spatial Version of Data: 1
 Soil Map Compilation Scale: 1:24000

Map comprised of aerial images photographed on these dates:
 5/9/1993; 8/16/1998; 9/12/1998

The orthophoto or other base map on which the soil lines were compiled and digitized probably differs from the background imagery displayed on these maps. As a result, some minor shifting of map unit boundaries may be evident.

USDA Natural Resources Conservation Service

| | | | |
|--|---------------------------|--|-------------------------------|
| <p>YOUNGDAHL CONSULTING GROUP INC. GEOTECHNICAL • ENVIRONMENTAL • MATERIALS TESTING</p> | Project No.: 07145.000 | <p>PRELIMINARY SOIL MAP White Rock & Scott Road 1400 Acre Property Folsom, California</p> | <p>FIGURE A-35</p> |
| | May 2007 | | |

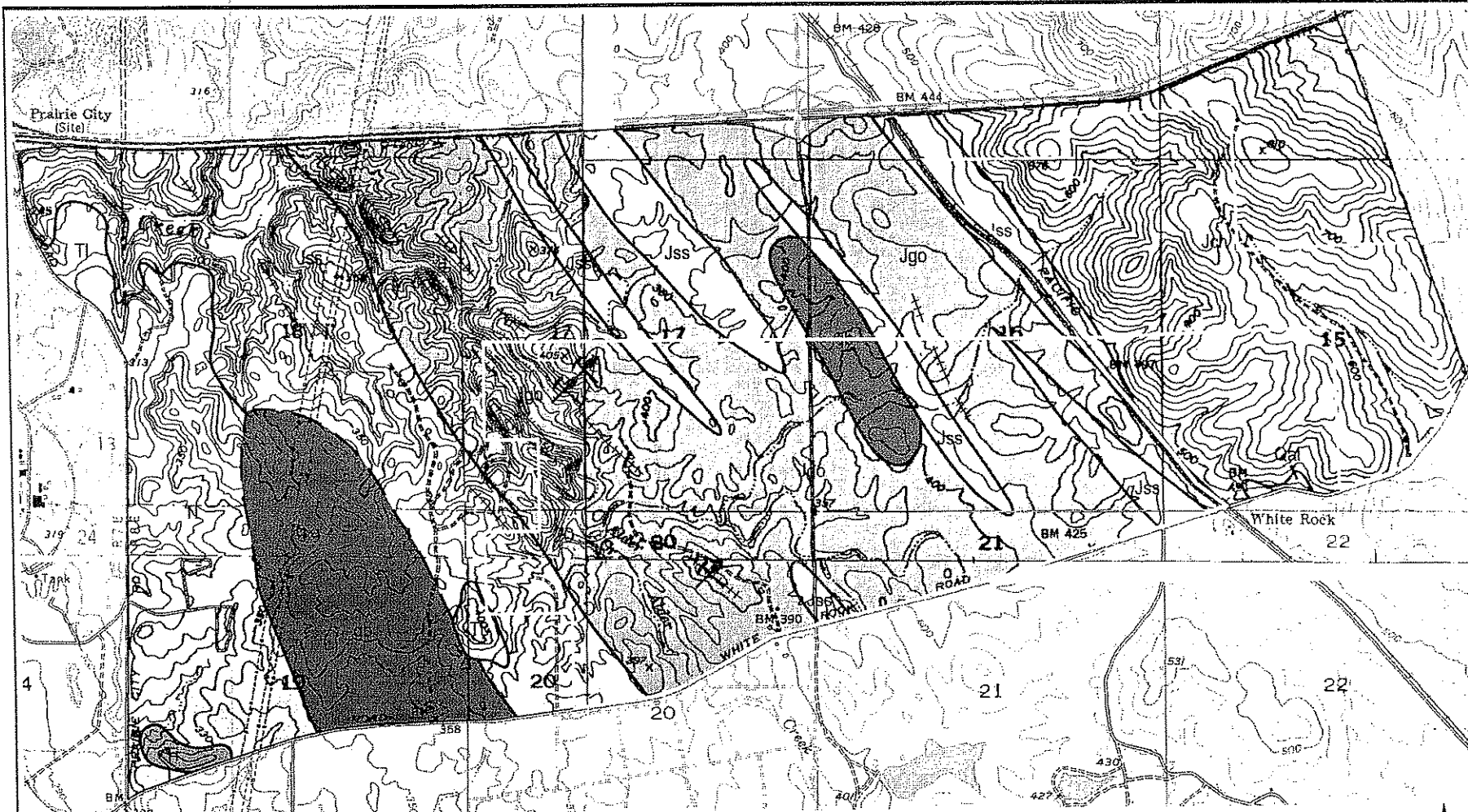

- Quartz Vein
- Fault Trace
- Geologic Contact
- t - Dredge and Mine Tailings

- Qal - Quaternary Alluvium
- Ti - Ione Formation (clays, sands)
- TI - Older Alluvial Sand, Silt, and Conglomerate (Laguna Formation)
- Jss - Salt Springs Slate
- Jgo - Gopher Ridge Volcanics and Associated Gabbro Intrusives
- Jch - Copper Hill Volcanics
- mv - Metavolcanics of the Foothill Melange
- gb - Gabbro

- Approximate Site Boundary
- Historic Mine Site

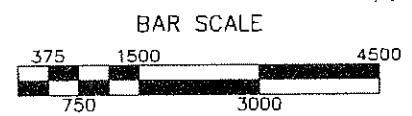

PREPARED BY: R. MALLORY
 DRAWN BY: M. GOOLSBY
 REVIEWED BY: D. SEDERQUIST
 BASE MAP DATA: MCKAY & SOMPS

AKT INVESTMENTS, INC.
**WHITE ROCK ROAD AND
 SCOTT ROAD
 PRELIMINARY GEOLOGIC MAP**
 SACRAMENTO COUNTY, CA

DATE: MAY 2007
 SCALE: 1" = 1600'
 JOB NO. E071461000
 FIGURE A-36

YOUNGDAHL
 CONSULTING GROUP INC.
 1134 Glenview Court, Suite 2
 Roseville, CA 95678
 916.533.0633
 916.533.7833
 916.533.7833



APPENDIX F5

Preliminary Geotechnical Engineering Report –
GenCorp South Folsom Sphere of Influence Property

Preliminary Geotechnical Engineering Report

GENCORP SOUTH FOLSOM

SPHERE OF INFLUENCE PROPERTY

Folsom, Sacramento County, California

WKA No. 7712.03

January 31, 2008

Prepared For:

GenCorp Realty Investments LLC

620 Coolidge Drive, Suite 100

Folsom, California 95630

Preliminary Geotechnical Engineering Report
GENCORP SOUTH FOLSOM SPHERE OF INFLUENCE PROPERTY
Sacramento County, California

TABLE OF CONTENTS

| | |
|--|----|
| INTRODUCTION..... | 1 |
| Scope..... | 1 |
| Figures..... | 2 |
| Project Description..... | 2 |
| FINDINGS | 2 |
| Site Description..... | 2 |
| Preliminary Soil Description and Percolation Characteristics | 4 |
| Site Geology..... | 7 |
| Subsurface Conditions | 8 |
| Ground Water..... | 9 |
| CONCLUSIONS..... | 9 |
| Building Support..... | 9 |
| Existing Pond Embankment..... | 9 |
| Naturally Occurring Asbestos Potential..... | 10 |
| Excavation Conditions | 11 |
| Rippability..... | 11 |
| Soil Expansion Potential..... | 11 |
| Material Suitability | 12 |
| Ground Water and Seepage..... | 12 |
| Seasonal Water..... | 12 |
| Seismic Code Parameters – 2007 CBC/ASCE 7-05 | 13 |
| Soil Corrosion Potential..... | 14 |
| PRELIMINARY RECOMMENDATIONS..... | 14 |
| Foundation Alternatives | 14 |
| Earthwork..... | 15 |
| Monitoring During Earthwork | 16 |
| Interior Floor Slab Support | 17 |
| Pavement Subgrade Quality..... | 17 |
| Future Studies | 19 |
| LIMITATIONS | 19 |



Preliminary Geotechnical Engineering Report
GENCORP SOUTH FOLSOM SPHERE OF INFLUENCE PROPERTY
Sacramento County, California

TABLE OF CONTENTS, Continued

FIGURES

| | |
|--|----------|
| Vicinity Map | Figure 1 |
| Soil Survey Map..... | Figure 2 |
| Geologic Map..... | Figure 3 |
| Unified Soil Classification System | Figure 4 |



Preliminary Geotechnical Engineering Report

GENCORP SOUTH FOLSOM SPHERE OF INFLUENCE PROPERTY

Sacramento County, California

WKA No. 7712.03

January 31, 2008

INTRODUCTION

We have completed a preliminary geotechnical engineering evaluation of the GenCorp South Folsom Sphere of Influence Property located in eastern Sacramento County, California. Our work has been performed in accordance with authorization on January 22, 2008 from Mr. Michael Pavik, and the scope of work outlined in our proposal letter dated January 24, 2008.

Scope

Our scope of work included the following tasks:

1. review of historic USGS topographic maps, geologic maps, Soil Conservation Service (SCS) soil survey maps, and aerial photographs of the property;
2. site reconnaissance;
3. review of previous investigations we accomplished on adjacent properties (including test pits, seismic refraction surveys, and laboratory testing of selected soil samples); and,
4. preparation of this report.

Supplemental information used in the preparation of this report included review of our *Preliminary Geotechnical Engineering Report* prepared for the Folsom 1400 Property (WKA No. 6449.02, dated March 23, 2005), located adjacent to the subject site to the east, and review of our *Preliminary Geotechnical Engineering Report* prepared for Carpenter Ranch (WKA No. 7757.01, dated September 6, 2007), located adjacent to the subject site to the north. Information contained within those reports was utilized in the preparation of this report.

Figures

Our report contains a Vicinity Map showing the location of the subject property (Figure No. 1); a Soils Map indicating the distribution of surface soils at the site (Figure No. 2); a Geologic Map (Figure No. 3); and, an explanation of the Unified Soil Classification System (Figure No.4).

Project Description

Based upon the information provided, we understand the site is planned for mostly single-family residential development, with some multi-family residential development and office and commercial property. Open space and parks will be included, as well as an elementary school site. We assume single-family residential construction will consist of one- and two-story, wood-frame houses with interior concrete slab-on-grade floors. Associated development will include construction of underground utilities and roadways.

FINDINGS

Site Description

The GenCorp South Folsom Sphere of Influence Property includes two areas totaling about 610 acres east of Prairie City Road and north of White Rock Road in eastern Sacramento County, California (see Figure 1). The northern property is defined by Sacramento County Assessor Parcel Number 072-0231-048, and the southern property is defined by Sacramento County Assessor Parcel Numbers 072-0060-072 and 072-0060-074.

The larger southern property is bounded to the north (Carpenter Ranch) and east (Folsom 1400 Property) by grazing land; to the south by White Rock Road; and, to the west by Prairie City Road. The boundary of the area is defined on all sides by cattle fencing. At the time of our site reconnaissance, the southern portion of this area consisted of grazing land covered with seasonal grasses, weeds and mature trees. The northern portion supported a heavy concentration of trees relative to the remainder of the site. Numerous rock outcrops were visible across the site. A dirt access road from White Rock Road near the eastern site boundary terminated easterly of the



property at the Circle B Ranch. A pond roughly three to five acres in size was observed on the northern portion of the property in a topographically low area. An earth dam on the order of 15 to 20 feet in height was observed on the north side of the pond, and a large concentration of tules was observed within the center of the pond. Depth of the pond is not known. Further observation of the site revealed indications that the near surface materials northerly and easterly of the pond have been excavated. Mounds and depressions from one to five feet in height and depth were observed. The mounds consist primarily of a mixture of quartz and slate, and larger cobble size pieces of quartz covered much of the ground surface around this area. Mature oak trees were observed growing in the mounds and in the associated depressions. A ditch approximately three to five feet wide by about three feet deep traverses this portion of the property. At the time of our site reconnaissance, the ditch contained about one foot of water. The ditch may be associated with the former Natomas Ditch that carried water to dredge fields westerly of the subject property during past gold mining activity. The pond, mounds and ditch are located in an area designated as open space on a site plan prepared by MacKay and Somps dated January 23, 2008.

An alignment of towers supporting high voltage power lines was observed traversing through the central portion of the southern property trending roughly northeast to southwest. A graveled road originating from Prairie City Road near the west central boundary of the site leads to a fenced, excavated area approximately one thousand feet east of Prairie City Road. The western boundary of the excavated area was approximately 20 feet deep. The excavated area is shallower to the east. A road within the fenced area circles the bottom of the excavation, and a tarped mound of soil is located near the eastern boundary of the excavated area. Numerous monitoring wells were observed around the excavation and scattered across this portion of the site. A concentrated rectangular shaped array of monitoring wells, some equipped with monitoring gauges, was observed immediately east of Prairie City Road. The array of wells covered a ground surface area approximately 20 feet wide by about 40 feet in length. An area approximately 500 feet by 500 feet was observed immediately south of the excavated area with disturbed surface materials indicated by hummocky topography and the presence of larger aggregate sizes at the surface. Most of these features are located in a future park site as shown on the Mackay and Somps site plan; however, the area with disturbed surface materials about 500 feet square may exist in an area designated for high density residential development.



The northernmost property is irregularly shaped and is bounded to the north by Alder Creek; to the east by Carpenter Ranch; and, to the south and east by Prairie City Road. At the time of our site reconnaissance, vegetation across the site consisted of a light to moderately thick growth of annual grasses and weeds. Mature trees were observed growing on the northern half of this area near Alder Creek and along ravines located near both the western and eastern boundaries. The surface materials across the central portion of the northern property appear to have been disturbed as indicated by hummocky topography and the presence of dredge tailings located near the northeastern portion of the area. Dredge tailings that are mounded around a low-lying area are on the order of 10 to 20 feet in height. We were not able to determine how deep the area had been dredged at the time of our site reconnaissance. Alder Creek was observed near the northern boundary traversing roughly east to west. The creek appeared to be about 40 to 50 feet wide and contained heavy concentrations of tules within the stream, and blackberry bushes along the creek banks. A few trees were observed growing within the creek.

The natural topography across the southern property varies between undulating and gently rolling terrain with surface elevations ranging between approximately +300 to +380 feet relative to mean sea level (msl), and the topography across the northern property is undulating with steep ravines with surface elevations ranging between approximately +240 to +310 feet msl based on review of the USGS *Topographic Map of the Buffalo Creek Quadrangle, California*, dated 1967 (photorevised 1980) and the USGS *Topographic Map of the Folsom Quadrangle, California*, dated 1967 (photorevised 1980).

Review of available aerial photographs taken in 1963, 1971, 1976, 1984 and 1991 indicate the property has been undeveloped and used for grazing cattle since at least 1963. The high voltage power line alignment located on the southern property appears to have been in existence since before 1971. The reservoir in the northern portion of the southern property is visible in the 1984 photo, and improvements to the Prairie City Road/Highway 50 intersection are visible in the 1991 photo. Unimproved roads are also visible on the property in the aerial photographs.

Preliminary Soil Description and Percolation Characteristics

Review of the April 1993 U.S. Department of Agriculture, Soil Conservation Service (SCS) *Soil Survey of Sacramento County, California*, indicates the near-surface soils on the subject property



consist of ten different soil types including “Argonaut-Auburn complex, 3 to 8 percent slopes (107)”; “Fiddymment fine sandy loam, 1 to 8 percent slopes (145)”; “Hicksville sandy clay loam, 0 to 2 percent slopes, occasionally flooded (160)”; “Pits (190)”, “Red Bluff loam, 2 to 5 percent slopes (192)”; “Red Bluff-Redding complex, 0 to 5 percent slopes (193)”; “Red Bluff-Xerorthents, dredge tailings complex, 2 to 50 percent slopes (196)”; “Vleck gravelly loam, 2 to 15 percent slopes (235)”; “Whiterock loam, 3 to 30 percent slopes (237)”; and, “Xerorthents, dredge tailings, 2 to 50 percent slopes (245).” The approximate distribution of these soils is indicated on Figure 2.

The following is a description of each soil type and the percolation characteristics as described by the U.S. Department of Agriculture, *SCS Soil Survey of Sacramento County, California*. Where appropriate, we have included the Unified Soil Classification Symbol (USCS) corresponding to each soil type. An explanation of the USCS is included as Figure 4.

- The Argonaut-Auburn complex (No. 107) consists of about 45 percent Argonaut soil and 35 percent Auburn soil. The Argonaut surface layer is typically reddish yellow and light yellowish brown loam (ML/CL) about 8 inches thick. The lower 15 inches is a claypan of brown and red clay and clay loam (CL/CH). The soils are underlain by weathered metamorphic rock. In some areas the surface layer is gravelly loam or silt loam (GM/ML). Permeability is very slow, and the shrink-swell potential is high.

The Auburn surface layer is typically brown, reddish yellow and yellowish red loam (ML/CL) about 14 inches thick. The soils are underlain by weathered metamorphic rock. Permeability is moderate.

- The Fiddymment fine sandy loam (No. 145) typically consists of brown and yellowish brown fine sandy loam (SM) and loam (ML/CL) from one to two feet in thickness. The near-surface soils are underlain by a claypan of brown clay loam (CL) about one foot thick, and by a light yellowish brown hardpan (CL/SC) that is cemented with silica. Siltstone or sandstone typically exists at a depth of about three to four feet. Permeability is very slow, and the shrink-swell potential is moderate.
- The Hicksville sandy clay loam profile (No. 160) typically consists of a surface layer of dark brown sandy clay loam (SM/SC) about six inches thick. The subsoil is brown



sandy clay loam (CL/SC) about 22 inches thick. The underlying material is light olive gray very gravelly sandy clay loam (GM/GC) about 14 inches thick. Permeability is moderately slow, and the shrink-swell potential is moderate.

- Pits (No. 190) typically consists of sand and gravel in shallow pits that were exposed during early placer mining operations. Most areas of this unit have been excavated and the ground is highly disturbed.
- The Red Bluff loam (No. 192) consists of a surface layer of brown loam (CL/ML) about 6 inches thick, underlain to a depth of about three feet by reddish brown and yellowish red clay loam (CL) and red gravelly clay (GC). Yellowish red, red, and brown gravelly clay loam (GC) exists to a depth of about seven feet. Hardpan is sometimes found at depths of four to five feet. Permeability is moderately slow, and the shrink-swell potential is low to moderate.
- The Red Bluff-Redding complex (No. 193) consists of about 45 percent Red Bluff soil and 40 percent Redding soil. The surface layer of the Red Bluff soil is a brown loam (CL/ML) about 8 inches thick. The upper part of the subsoil is reddish brown and yellowish red clay loam (CL) about 17 inches thick. The next part is yellowish red and red gravelly clay (GC) about 18 inches thick. The lower part to a depth of 68 inches is yellowish red, red, and light brown very gravelly clay loam (GC). In some areas the surface layer is sandy loam (SM). Permeability is moderately slow in the Red Bluff soil, and the shrink-swell potential is low to moderate.

The surface layer of the Redding soil is a strong brown gravelly loam (GC/GM) about 7 inches thick. The upper part of the subsoil is yellowish red loam (CL/ML) and gravelly loam (GC/GM). The lower part is a claypan of reddish brown and yellowish red gravelly clay (GC/CH/CL) about 8 inches thick. Below this to a depth of 66 inches is a very gravelly hardpan that is strongly cemented with silica. In some areas the surface layer is gravelly sandy loam (GM/SM), loam (CL/ML), or sandy loam (SM). Permeability is very slow in the Redding soil, and the shrink-swell potential is low to high.



- The Red Bluff-Xerorthents, dredge tailings complex (No. 196) is similar to the Red Bluff soil described previously (No. 193), except where it has been disturbed by placer mining operations and consists mostly of gravel and cobbles.
- The Vleck gravelly loam (No. 235) typically consists of a surface layer of gray and light gray gravelly loam (SM/GM) about 13 inches thick. The upper 12 inches of the subsoil is a claypan of light brownish gray clay (CL/CH) that has light gray bleached coatings. The lower 7 inches is mixed pale yellow and light yellowish brown sandy clay loam (SC/CL). The substratum is a pale yellow hardpan that is strongly cemented with silica. It is about 18 inches thick. Pale yellow, weakly consolidated sediments are at a depth of about 50 inches. In some areas the surface layer is gravelly sandy loam (GM/SM), sandy loam (SM), or loam (CL/ML). In other areas the subsoil is gravelly clay (GC). Permeability is very slow in the Vleck soil, and the shrink-swell potential is high.
- The Whiterock loam (No. 237) typically consists of a thin layer of brown loam (ML/CL), silt loam (ML), gravelly silt loam (GM/ML), or gravelly loam (SM/GM) underlain by highly fractured metasedimentary rocks. Permeability is moderate, and the shrink-swell potential is low.
- Xerorthents, dredge tailings (No. 245) consists of material that has a high content of gravel and cobbles deposited as tailings after most of the fine-grain soils were washed from them during gold dredging activities.

Site Geology

As shown on Figure 3, the southern property is underlain by Gopher Ridge Volcanics, Salt Springs Slate, and gabbroic rocks in the eastern portion, and by the Laguna Formation and Ione Formation in the western portion as identified by the California Department of Conservation: Mines and Geology publication, *Generalized Geologic Map of the Folsom 15-Minute Quadrangle*. The northern property is underlain by the Salt Springs Slate and the Laguna Formation.



The Gopher Ridge Volcanic formation consists mostly of metamorphosed volcanic mafic to andesitic pyroclastic rocks, lava, and pillow lava. The Salt Springs Slate consists mostly of dark gray slate with subordinate tuff, greywacke, and rare conglomerate. Quartz veins are associated with the Salt Springs Slate and the Gopher Ridge Volcanics, and generally trend southeast-northwest. The gabbroic rocks underlying the southern property belong to the Foothill Melange-Ophiolite Terrane. The Laguna Formation consists of alluvial sands, silts, and conglomerate, and the Ione Formation consists of interlayered beds of kaolinitic clay, quartz sand, and sandy clay.

A geologic map included in the *Mineral Land Classification of the Folsom 15-Minute Quadrangle, Sacramento, El Dorado, Placer, and Amador Counties, California* (California Department of Conservation Division of Mines and Geology Open-File Report 84-50, 1984) and the *Fault Activity Map of California and Adjacent Areas* (California Department of Conservation Division of Mines and Geology Geologic Data Map No. 6, 1994) indicate the west branch of the Bear Mountains Fault is located approximately 5 miles east of the site, and represents the westernmost fault within the "Foothills Fault Zone." The property is not identified within an *Alquist-Priolo Fault Study Zone*, meaning that the State has not identified any active faults (activity within the last 11,000 years) on the property. The Bear Mountains Fault is mapped as a pre-Quaternary fault (not active within the last 1.6 million years), except for the "Rescue Lineament," which may have been active in late Quaternary time. The Rescue Lineament is located about 13 miles northeast of the site.

Subsurface Conditions

Test pits excavated on adjacent properties with geologic conditions similar to the subject site generally encountered clayey, sandy silts and silty clays less than two feet thick in areas underlain by slightly weathered metamorphic and gabbroic rock. Depth of excavation with a Case 580 backhoe within the metamorphic and gabbroic rocks was generally limited to five feet; however, hard rock that could not be excavated was also encountered at depths less than five feet in some areas. Subsurface conditions in areas underlain by the Laguna Formation consisted of silty sands, sandy silts and sandy gravels underlain by cemented sandy gravels and cobbles to a maximum depth of about 10 feet. The zone of cementation was encountered at variable depths generally starting at depths between two and six feet below the ground surface.



Ground Water

Ground water elevation maps prepared by the Department of Water Resources Public Works Agency County of Sacramento (Spring and Fall, 1979 through 2003) indicate the ground water elevation in the site vicinity fluctuating between approximately 110 feet above mean sea level and 140 feet above mean sea level. This information would place ground water depths at least 100 feet below site elevations.

CONCLUSIONS

Building Support

We anticipate that undisturbed native soils and weathered rock at the site would be capable of supporting the proposed construction provided the appropriate foundation system is used to support the buildings. We also anticipate that engineered fills composed of on-site materials or approved import soils that are placed and compacted in accordance with general engineering practices will be suitable for support of the proposed structures and pavements.

Loose soils resulting from previous site use (including shallow surface mining deposits, dredge tailings, and soils disturbed during environmental remediation activity) should not be relied upon for structural support unless the loose materials are completely removed and placed as properly compacted engineered fill.

Existing Pond Embankment

Evaluation of the stability of the on-site pond embankment is beyond the scope of this preliminary report. A detailed stability evaluation should be accomplished for the embankment during future geotechnical investigations to determine if the embankment requires improvement. Improvement, if required, could include construction of a buttress fill on the downstream side of the embankment to increase embankment stability.



Depending on embankment height and storage capacity, the embankment may be within the jurisdictional oversight of the Division of Safety of Dams. Jurisdictional dam size is typically any embankment greater than 25 feet in height (measured from the downstream toe to the spillway crest elevation) that has a storage capacity of greater than 15 acre-feet, or any embankment with a storage capacity greater than 50 acre-feet unless the embankment height is less than 6 feet.

Naturally Occurring Asbestos Potential

The southern property is underlain by gabbroic rock and the Gopher Ridge Volcanics geologic unit. Special Report 192 prepared by the Department of Conservation California Geological Survey "*Relative Likelihood for the Presence of Naturally Occurring Asbestos in Eastern Sacramento County, California*" indicate these geologic units are moderately likely to contain naturally occurring asbestos. These geologic units are not present on the northern property.

In September 2004, the Sacramento Metropolitan Air Quality Management District (SMAQMD) issued an advisory (Advisory #04-05 revised) that the potential exists for NOA to be encountered in gabbroic rocks and the Gopher Ridge Volcanics. Consequently, the SMAQMD currently requires that earthmoving activities performed in areas underlain by these geologic units be performed in accordance with dust mitigation measures described in the California Air Resources Board's *Asbestos Airborne Toxic Control Measure for Construction, Grading, Quarrying, and Surface Mining Operations (ATCM)*. The SMAQMD requires that specific dust mitigation measures proposed for such projects must be outlined in an Asbestos Dust Mitigation Plan, which is to be approved by the SMAQMD prior to commencing earthmoving activities.

A project may be granted exemption from the ATCM requirements (by SMAQMD) if a geologic evaluation has been conducted by a registered geologist who makes a determination that asbestos does not exist in the area to be disturbed. To obtain a geologic exemption for projects within the specified geologic units, the SMAQMD currently requires that sampling and testing for NOA be performed in accordance with the California Air Resources Board Method 435 (CARB 435), which specifies testing of one three-point composite sample (one sample consisting of material from three different locations) per acre of land to be disturbed.



Excavation Conditions

Excavation of the on-site rock units will vary throughout the property due to differences in composition, fracturing (jointing) and degree of weathering. The subject site contains rocky surface soils, underlain by variably weathered metamorphic and gabbroic rock. The uppermost soil and weathered rock should be excavatable with conventional excavation equipment typically used in the area. The metamorphic and gabbroic rock will be more difficult to excavate, and likely will require large dozers and excavators or possibly blasting to achieve deep excavations.

Rippability

Seismic refraction traverses performed at adjacent sites with similar subsurface rock conditions indicate compressional seismic wave velocities up to approximately 2,500 feet per second (fps) within the upper few feet of the ground surface. Less weathered (harder) metavolcanic and gabbroic rock with interpreted seismic wave velocities between 10,000 and 16,000 feet per second (fps) exist at greater depths.

Based upon the interpreted seismic velocities and the Caterpillar Performance Handbook, 36th Edition, dated April 2006, the near-surface soil/rock profile across most of the property would be rippable with a Caterpillar D8R or larger bulldozer equipped with a single tooth ripper. Less weathered metamorphic and gabbroic rock at greater depths would require larger equipment (D10 or larger) or blasting to achieve excavation. It is possible that local harder deposits of rock could be encountered at shallow depths within the upper portions of the site that also could require either larger construction equipment or blasting to achieve excavation. Based on our experience on nearby projects and the variable hardness of rock within the vicinity of the site, we conclude that it would be prudent to select equipment larger than a Caterpillar D8R that will be capable of excavating harder deposits of rock that will likely be encountered at the site.

Soil Expansion Potential

Laboratory testing of the surface and near-surface soils at adjacent sites indicates soils with moderate to high expansion potentials when tested in accordance with the ASTM D4829 (UBC 29-2) test method. Previous experience also indicates highly expansive clay soils may exist directly above the weathered rock at the site, and that highly expansive materials may be



associated with the Ione formation near the intersection of Prairie City Road and White Rock Road. Use of expansive materials should be avoided within building pads. If expansive materials are exposed at subgrade level, they should be excavated and replaced with low expansion materials.

Material Suitability

The native soils and weathered rock will be suitable for use as engineered fill, provided they do not contain significant concentrations of vegetation or debris, and they are at an appropriate moisture content to allow proper compaction. Clay soils and expansive materials should not be used near the surface of building pads, or directly behind retaining walls, but will be suitable for use in deeper fills. However, experience suggests that the volume of clay in relation to rocky materials is relatively small, resulting in a mixture of materials that is not very expansive. Deeper excavations may result in larger rocks that will not be suitable as engineered fill unless broken down into smaller fragments (about 12 inches or less) that can be properly compacted.

Ground Water and Seepage

Review of available ground water information in the vicinity of the site, suggests that the static ground water table should not adversely affect construction of the proposed improvements. However, experience at other sites underlain by weathered bedrock at shallow depths indicates that seepage likely will be encountered during development of the property, requiring the construction of subdrainage. Typical subdrains consist of perforated pipe and gravel, surrounded by nonwoven geotextile fabric. Design of subdrains should be performed during construction when actual seepage conditions are exposed; however, there should be a contingency in the project budget for subdrain construction.

Seasonal Water

The near-surface soils will be in a near-saturated condition during and for a considerable period following the rainy season. Grading operations attempted following the onset of winter rains and prior to prolonged drying periods will be hampered by high soil moisture contents. Such soils,



intended for use as engineered fill, will require considerable aeration to reach a moisture content that will permit the recommended compaction to be achieved.

Seismic Code Parameters – 2007 CBC/ASCE 7-05

The 2007 California Building Code (CBC) references Chapter 11 of ASCE 7-05, *Seismic Design Criteria*. ASCE 7-05 seismic design uses the Maximum Considered Earthquake (MCE) ground motion for most design not requiring site-specific response analysis. Section 11.4 requires the determination of parameters S_S and S_1 , the 0.2 second and 1.0 second spectral response accelerations for code site class B, respectively, as determined by the maps prepared by the United States Geological Survey (USGS) presented in ASCE 7-05 Figures 22-3 and 22-4. Alternatively, the site parameters may be determined based on the site latitude and longitude using the public domain computer program developed by the USGS. In our opinion the following parameters may be used for seismic design at the project using the 2007 CBC.

| Latitude: 38.6231° Longitude: 121.1419° | ASCE 7-05 Table/Figure | Factor/Coefficient | Value |
|--|---------------------------|--------------------|---------|
| Short-Period MCE at 0.2s | Figure 22-3 | S_S | 0.40 g* |
| 1.0s Period MCE | Figure 22-4 | S_1 | 0.20g* |
| Soil Profile Type | Table 20.3-1 | Site Class | C |
| Site Coefficient | Table 11.4-1 | F_a | 1.2 |
| Site Coefficient | Table 11.4-2 | F_v | 1.6 |
| Adjusted MCE Spectral Response Parameters | Equation 11.4-1 | S_{MS} | 0.47 |
| | Equation 11.4-2 | S_{M1} | 0.32 |
| Design Spectral Acceleration Parameters | Equation 11.4-3 | S_{DS} | 0.32 |
| | Equation 11.4-4 | S_{D1} | 0.21 |
| Seismic Design Category | Table 11.6-1 | Occupancy I to III | B |
| | | Occupancy IV | C |
| Seismic Design Category | Table 11.6-2 | Occupancy I to IV | D |

* Values calculated by linear interpolation.



Soil Corrosion Potential

Published literature¹ defines a corrosive area as an area where the soil and/or water contains more than 500 ppm of chlorides, more than 2000 ppm of sulfates or has a pH of less than 5.5. Results of corrosivity tests accomplished on soils from adjacent sites that are similar to the subject site suggest that the native soils are not unusually corrosive to buried metal or to steel reinforcement properly embedded within Portland cement concrete, and that ordinary Type I/II Portland cement would be considered suitable for use at the site, assuming minimum concrete cover is maintained over the reinforcement.

PRELIMINARY RECOMMENDATIONS

Foundation Alternatives

Our experience in the area and on nearby projects indicates that the proposed single- and multi-family residential structures and commercial/office structures can be supported on conventional, shallow foundations bearing in nonexpansive soils and/or rock materials. Foundations deepened to bear on undisturbed bedrock could be used for additional support capacity. Special foundation design could be required in areas where expansive materials are present. Foundation design alternatives would include using deepened and heavily reinforced conventional foundations.

Typical foundations for one- and two-story residential construction supported on such soil/rock would consist of conventional foundations. Conventional foundations would be at least 12 inches deep containing at least two No. 4 rebar, one each placed top and bottom. Minimum foundation widths of 12 inches for continuous foundations and 18 inches wide for isolated spread foundations would be applicable. We anticipate bearing capacities on the order of 2500 pounds per square foot (psf) for dead plus live load would be applicable for residential foundations bearing in recompacted native materials, engineered fill, or a combination of these materials.

¹California Department of Transportation, Division of Engineering Services, Materials Engineering and Testing Services, Corrosion Technology Branch, *Corrosion Guideline*, Version 1.0, September 2003.



Commercial and office structures one- and two-stories in height could be supported upon continuous and isolated spread foundations extending roughly 18 inches below grade. Bearing capacities on the order of 3000 psf likely may be suitable for sizing foundations. Deepening of foundations would increase the allowable bearing capacity. Conventional foundations would contain reinforcement, such as No. 4 reinforcing bars placed near the top and bottom of the foundations.

Earthwork

Project specific geotechnical engineering investigations should be performed to develop site-specific grading recommendations. Of special importance for earthwork operations for this site will be the adequate removal of loose soils and undocumented fill material associated with previous site usage (mining, dredging, and environmental remediation) within proposed structural areas. Loose and undocumented materials should be removed to expose firm undisturbed ground. Excavations and depressions resulting from the removal of these items must be backfilled with engineered fill.

Removal of surface organics would depend on the condition and quantity of the organics at the time grading is to begin. Discing of the organics may be suitable for construction, if the organic concentrations are not too thick at the time of grading. Stripping of the organics likely would be required if organics are very thick, with strippings being completely removed from the site or used only in landscape areas. Tree removal (if any) at this site would include the entire rootball and all roots larger than ½-inch in diameter. Deeper ripping and processing to a depth of about 12 inches will be important to facilitate removal of root systems. Excavations and depressions resulting from the removal of trees must be backfilled with engineered fill.

Standard fill construction and compaction procedures, including uniform moisture conditioning of the on-site soils to an optimum moisture content at the time of compaction, will be important for proper support of the planned structures.

On-site soils and rock materials that are predominately less than 12 inches in maximum diameter may be used as engineered fill if they do not contain debris, organics or other deleterious materials. Rocks greater than 12 inches in diameter should be broken into pieces less than 12



inches across. Engineered fill is typically placed in thin lifts and compacted to not less than 90 percent relative compaction, or by several passes with a heavy, self-propelled sheepsfoot compactor if the material is rocky, at a moisture content of at least optimum moisture.

Sloping ground steeper than six horizontal to one vertical (6:1) is typically benched during placement of engineered fill with each bench consisting of a level terrace excavated horizontally at least four feet into the sloping ground. Benching should be done progressively at vertical increments not exceeding two feet. Fill placed on slopes that are steeper than four horizontal to one vertical (4:1) is typically keyed into the ground at the toe of the fill slope by excavating a 15-foot wide toe key along the toe of the fill slope that is excavated to a depth of at least two feet into dense soils or weathered rock.

Permanent excavation and fill slopes should be constructed at a slope gradient of two horizontal to one vertical (2:1) or flatter.

Typically only native soils (in lieu of select sand backfill) are recommended for use as backfill for utility trenches located within building footprints and extending at least five feet beyond the perimeter foundation to minimize water transmission beneath the homes. Utility trench backfill is generally thoroughly moisture conditioned to at least the optimum moisture content and mechanically compacted to the recommended density.

Monitoring During Earthwork

Based on our document review and surface reconnaissance, the property is underlain by metavolcanic and gabbroic rock. Although we did not observe asbestiform minerals in the project area during our preliminary site reconnaissance, it must be noted that naturally occurring asbestos (NOA) has occasionally been associated with metavolcanic and gabbroic rocks in close proximity to the site.

Based on our experience with other projects in the region, periodic geologic reconnaissance of soil/rock exposed by grading operations on the property may be recommended to document the absence/presence of NOA. Due to the geologic conditions at property, it is possible that Sacramento County would require submission of an *Asbestos Dust Mitigation Plan* for grading



operations at the site. Such a plan is commonly required to be in place for implementation in the event that NOA is encountered during the course of a project. Requirements for such plans are described in the California Air Resources Board's *Asbestos Airborne Toxic Control Measure for Construction, Grading, and Surface Mining Operations* (ATCM).

Interior Floor Slab Support

Interior residential and commercial/office concrete slab-on-grade floors can be suitably supported upon the properly prepared soil subgrades that are maintained in that condition (optimum moisture). Interior concrete slabs should be reinforced with reinforcing steel bars. Placement of the reinforcement near the mid-depth of the slab would be crucial to its performance. If expansive soils exist at subgrade elevation, pre-saturation of subgrade soils would be required for conventional floor slab systems used for residential construction. Pre-saturation of subgrade soils for concrete tilt-up construction is typically not recommended.

A typical capillary break (crushed rock) should underlie interior slabs-on-grade. If potential heavier floor loads are anticipated with commercial construction, the crushed rock thickness beneath interior slab-on-grade floors could be increased or Class 2 aggregate base compacted to at least 95 percent of the maximum dry density could be used. A vapor retarder membrane could be used where moisture sensitive floor coverings are to be used.

Pavement Subgrade Quality

Due to the rolling site terrain, we anticipate that subgrade conditions will vary considerably. Near surface clayey soils typically possess a Resistance ("R") value of 5, which would be an appropriate design value for clay subgrades. Laboratory testing and experience also suggests that subgrades consisting of weathered rock materials likely will possess an R-value of around 40. Using these design values and the design traffic indices contained in the "Design Practice Guide" prepared by the Sacramento County Transportation Division, dated June 1, 1999, we have calculated the following pavement section alternatives. The procedures used for designing the pavement section are in general conformance with the "Flexible Pavement Structural Design Guide for California Cities and Counties" and applicable portions of the Caltrans Highway Design Manual.



| PAVEMENT DESIGN ALTERNATIVES | | | |
|--|--------------------|----------------------------------|---------------------------------|
| R-Value = 5 | | | |
| Street Right-of-Way | Traffic Index (TI) | Type B Asphalt Concrete (inches) | Class 2 Aggregate Base (inches) |
| 40' and 50' Residential | 5.0 | 2½ | 11 |
| 56' to 74' without Bus Routes | 6.0 | 2½ | 15 |
| | | 3½* | 13 |
| 56' to 74' with Bus Routes and Cul-de-Sacs | 6.5 | 3 | 16 |
| | | 4* | 14 |
| 84' Streets | 9.0 | 4 | 23 |
| | | 5½* | 21 |
| 108' and 130' Streets | 10.0 | 5 | 25 |
| | | 6* | 24 |

| PAVEMENT DESIGN ALTERNATIVES | | | |
|--|--------------------|----------------------------------|---------------------------------|
| R-Value = 40 | | | |
| Street Right-of-Way | Traffic Index (TI) | Type B Asphalt Concrete (inches) | Class 2 Aggregate Base (inches) |
| 40' and 50' Residential | 5.0 | 2½ | 5 |
| 56' to 74' without Bus Routes | 6.0 | 2½ | 8 |
| | | 3½* | 6 |
| 56' to 74' with Bus Routes and Cul-de-Sacs | 6.5 | 3 | 9 |
| | | 4* | 6 |
| 84' Streets | 9.0 | 4 | 12 |
| | | 5½* | 10 |
| 108' and 130' Streets | 10.0 | 5 | 13 |
| | | 6* | 12 |

- includes Caltrans safety factor



Future Studies

We assume that the site will be developed individually with a variety of structures. Site-specific geotechnical engineering investigations must be performed for each project or group of projects as plans are developed and building types and locations are determined. The final report(s) should present specific recommendations for site preparation, foundation design, floor slab support, retaining wall design, site drainage, and pavement design. Future geotechnical investigations of this property should include test pits, soil sampling, laboratory testing and engineering evaluation. When the project reaches this stage of planning, we would be pleased to provide separate cost estimates for these services.

LIMITATIONS

The proceeding sections of this report should be considered a general overview of the geotechnical engineering aspects of site development. They are not intended for specific design or construction of any of the project improvements. At an appropriate time prior to development, our firm should be retained to conduct a comprehensive, site-specific geotechnical engineering investigation for this project.

We appreciate this opportunity to be of service. Please contact our office if you have any questions regarding our report or the geotechnical aspects of site development.

Wallace-Kuhl & Associates, Inc.

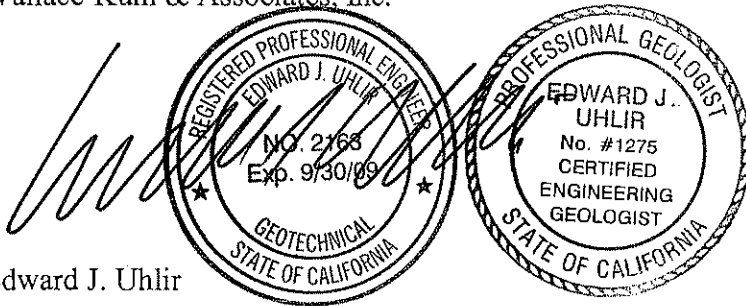

Edward J. Uhlir
Senior Engineer



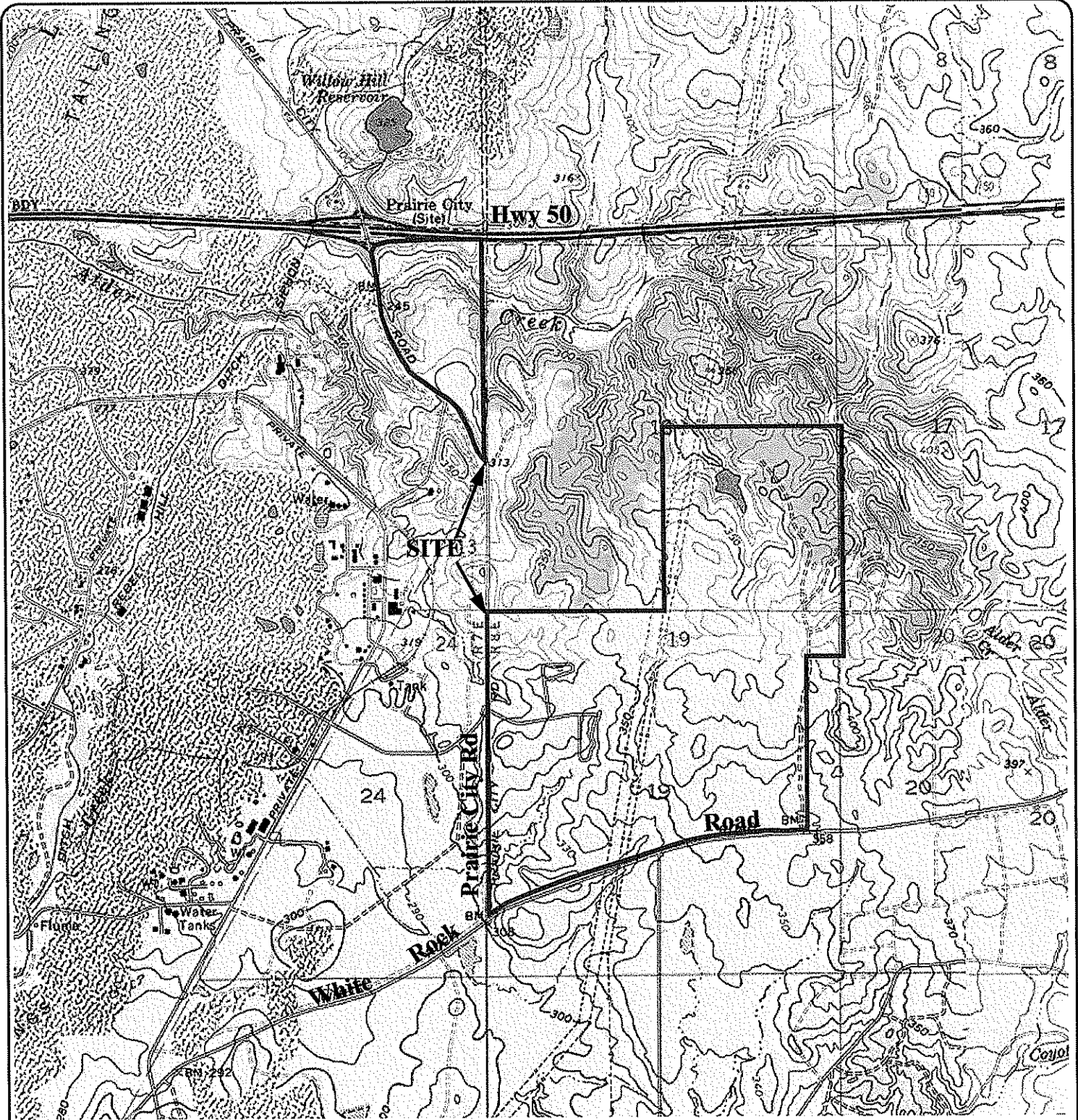

Adapted from the U.S. Geological Survey
7.5 minute topographic maps of the Folsom
and Buffalo Creek quadrangles, California, 1980.

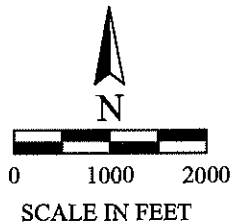

VICINITY MAP
GENCORP SOUTH FOLSOM
SPHERE OF INFLUENCE PROPERTY
 Sacramento County, California

| | |
|------------------------|------|
| FIGURE 1 | |
| DRAWN BY | HCS |
| CHECKED BY | EJU |
| PROJECT MGR | EJU |
| DATE | 1/08 |
| WKA NO. 7712.03 | |

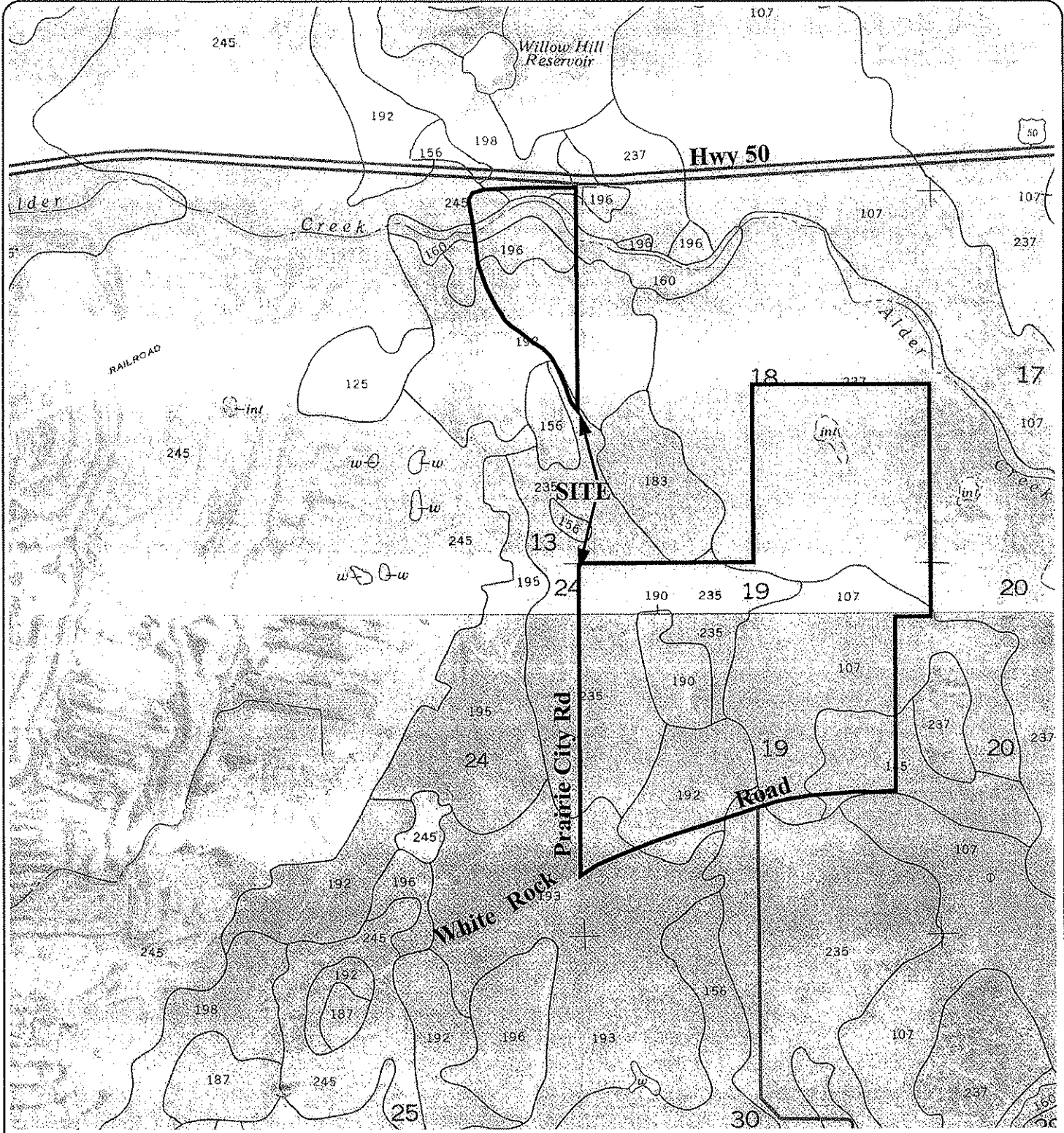

Adapted from the U.S. Department of Agriculture, Soil Conservation Service, and cooperating agencies. Base maps are orthophotographs prepared by the U.S. Department of the Interior, Geological Survey, from 1970-1977 aerial photography.

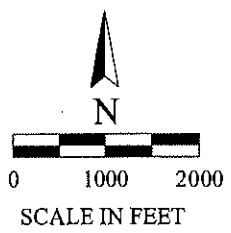





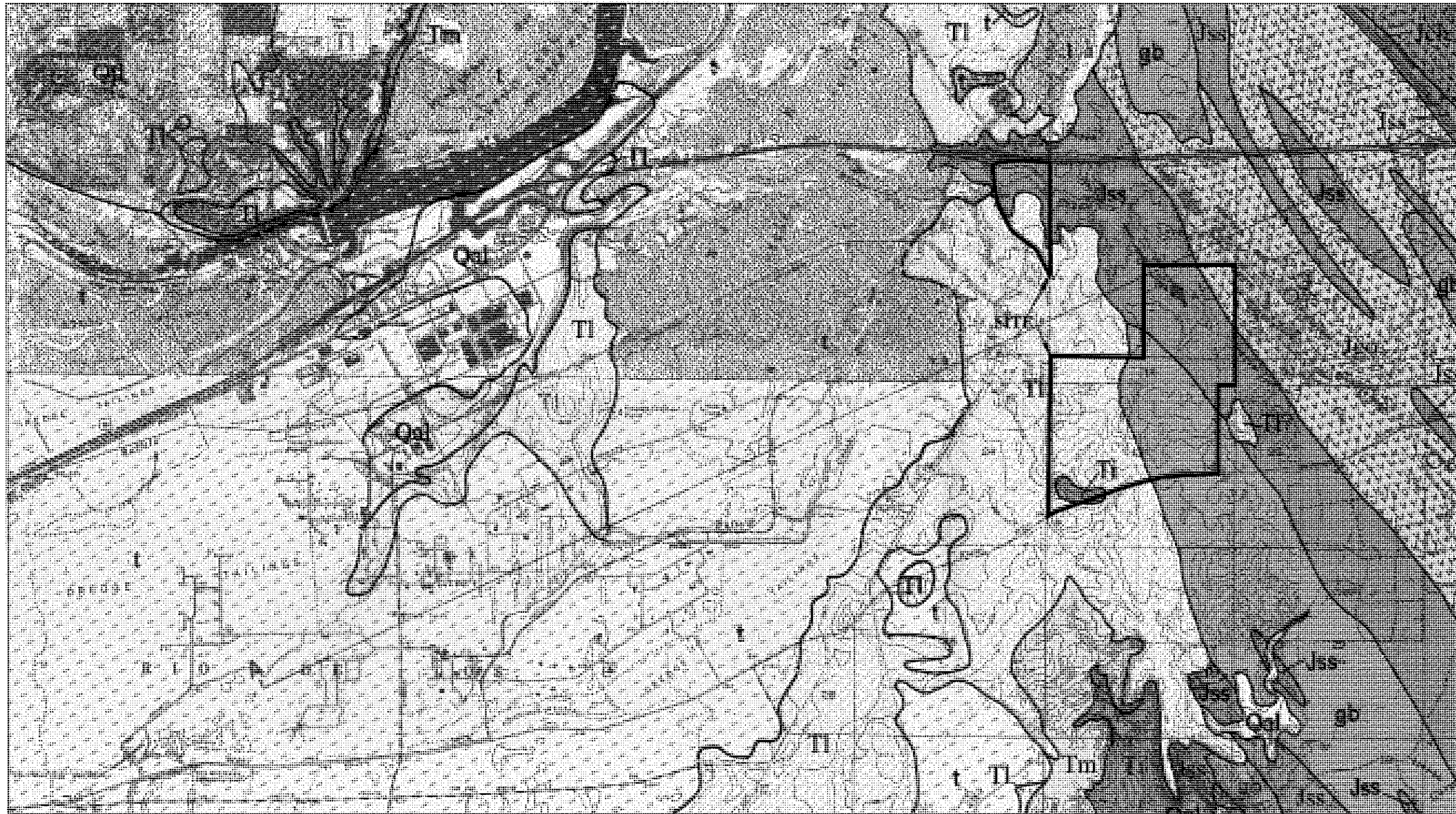







SOIL SURVEY MAP
GENCORP SOUTH FOLSOM
SPHERE OF INFLUENCE PROPERTY
 Sacramento County, California

| | |
|------------------------|------|
| FIGURE 2 | |
| DRAWN BY | HCS |
| CHECKED BY | EJU |
| PROJECT MGR | EJU |
| DATE | 1/08 |
| WKA NO. 7712.03 | |



Legend:

-  Project Boundary
-  Geologic Contact
-  Quartz veins
-  Dredge Tailings
-  Quaternary Alluvium
-  Turlock Lake Formation
-  Laguna Formation
-  Mehrten Formation
-  Ione Formation
-  Copper Hill Volcanics
-  Salt Springs Slate
-  Gopher Ridge Volcanics
-  Gabbroic Rock

Note: Adapted from the Generalized Geology of the Folsom 15-minute Quadrangle, compiled by R.C. Loyd, 1984.



0 1500 3000
SCALE IN FEET



**WALLACE-KUHL
& ASSOCIATES, INC.**

GEOLOGIC MAP

GENCORP SOUTH FOLSOM OF INFLUENCE PROPERTY













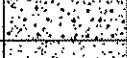

Sacramento County, California

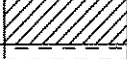
FIGURE 3



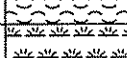



| | |
|-------------|------|
| DRAWN BY | HCS |
| CHECKED BY | EJU |
| PROJECT MGR | EJU |
| DATE | 1/08 |

WKA NO. 7712.03

UNIFIED SOIL CLASSIFICATION SYSTEM

| MAJOR DIVISIONS | SYMBOL | CODE | TYPICAL NAMES |
|---|---|---|--|
| COARSE GRAINED SOILS (More than 50% of soil > no. 200 sieve size) | GRAVELS | | |
| | GW |  | Well graded gravels or gravel - sand mixtures, little or no fines |
| | GP |  | Poorly graded gravels or gravel - sand mixtures, little or no fines |
| | GM |  | Silty gravels, gravel - sand - silt mixtures |
| | GC |  | Clayey gravels, gravel - sand - clay mixtures |
| | SANDS | | |
| | SW |  | Well graded sands or gravelly sands, little or no fines |
| | SP |  | Poorly graded sands or gravelly sands, little or no fines |
| FINE GRAINED SOILS (50% or more of soil < no. 200 sieve size) | SILTS & CLAYS | | |
| | <u>LL < 50</u> | | |
| | ML |  | Inorganic silts and very fine sands, rock flour, silty or clayey fine sands or clayey silts with slight plasticity |
| | CL |  | Inorganic clays of low to medium plasticity, gravelly clays, sandy clays, silty clays, lean clays |
| | OL |  | Organic silts and organic silty clays of low plasticity |
| | <u>LL ≥ 50</u> | | |
| MH |  | Inorganic silts, micaceous or diatomaceous fine sandy or silty soils, elastic silts | |
| CH |  | Inorganic clays of high plasticity, fat clays | |
| OH |  | Organic clays of medium to high plasticity, organic silty clays, organic silts | |
| HIGHLY ORGANIC SOILS | Pt |  | Peat and other highly organic soils |
| ROCK | RX |  | Rocks, weathered to fresh |
| FILL | FILL |  | Artificially placed fill material |

OTHER SYMBOLS

| | |
|---|---|
|  | = Drive Sample: 2-1/2" O.D. Modified California sampler |
|  | = Drive Sample: no recovery |
|  | = SPT Sample |
|  | = Initial Water Level |
|  | = Final Water Level |
|  | = Estimated or gradational material change line |
|  | = Observed material change line |
| <u>Laboratory Tests</u> | |
| PI = Plasticity Index | |
| EI = Expansion Index | |
| UCC = Unconfined Compression Test | |
| TR = Triaxial Compression Test | |
| GR = Gradational Analysis (Sieve) | |
| K = Permeability Test | |

GRAIN SIZE CLASSIFICATION

| CLASSIFICATION | RANGE OF GRAIN SIZES | |
|--|---------------------------------------|---------------------------------|
| | U.S. Standard Sieve Size | Grain Size in Millimeters |
| BOULDERS | Above 12" | Above 305 |
| COBBLES | 12" to 3" | 305 to 76.2 |
| GRAVEL coarse (c) fine (f) | 3" to No. 4 | 76.2 to 4.76 |
| | 3" to 3/4" 3/4" to No. 4 | 76.2 to 19.1 19.1 to 4.76 |
| SAND coarse (c) medium (m) fine (f) | No. 4 to No. 200 | 4.76 to 0.074 |
| | No. 4 to No. 10 | 4.76 to 2.00 |
| | No. 10 to No. 40 No. 40 to No. 200 | 2.00 to 0.420 0.420 to 0.074 |
| SILT & CLAY | Below No. 200 | Below 0.074 |



UNIFIED SOIL CLASSIFICATION SYSTEM
 GENCORP SOUTH FOLSOM
 SPHERE OF INFLUENCE PROPERTY
 Sacramento County, California

FIGURE 4

| | |
|-------------|------|
| DRAWN BY | GJF |
| CHECKED BY | EJU |
| PROJECT MGR | EJU |
| DATE | 1/08 |

WKA NO. 7712.03

APPENDIX F6

Conceptual Grading Plan

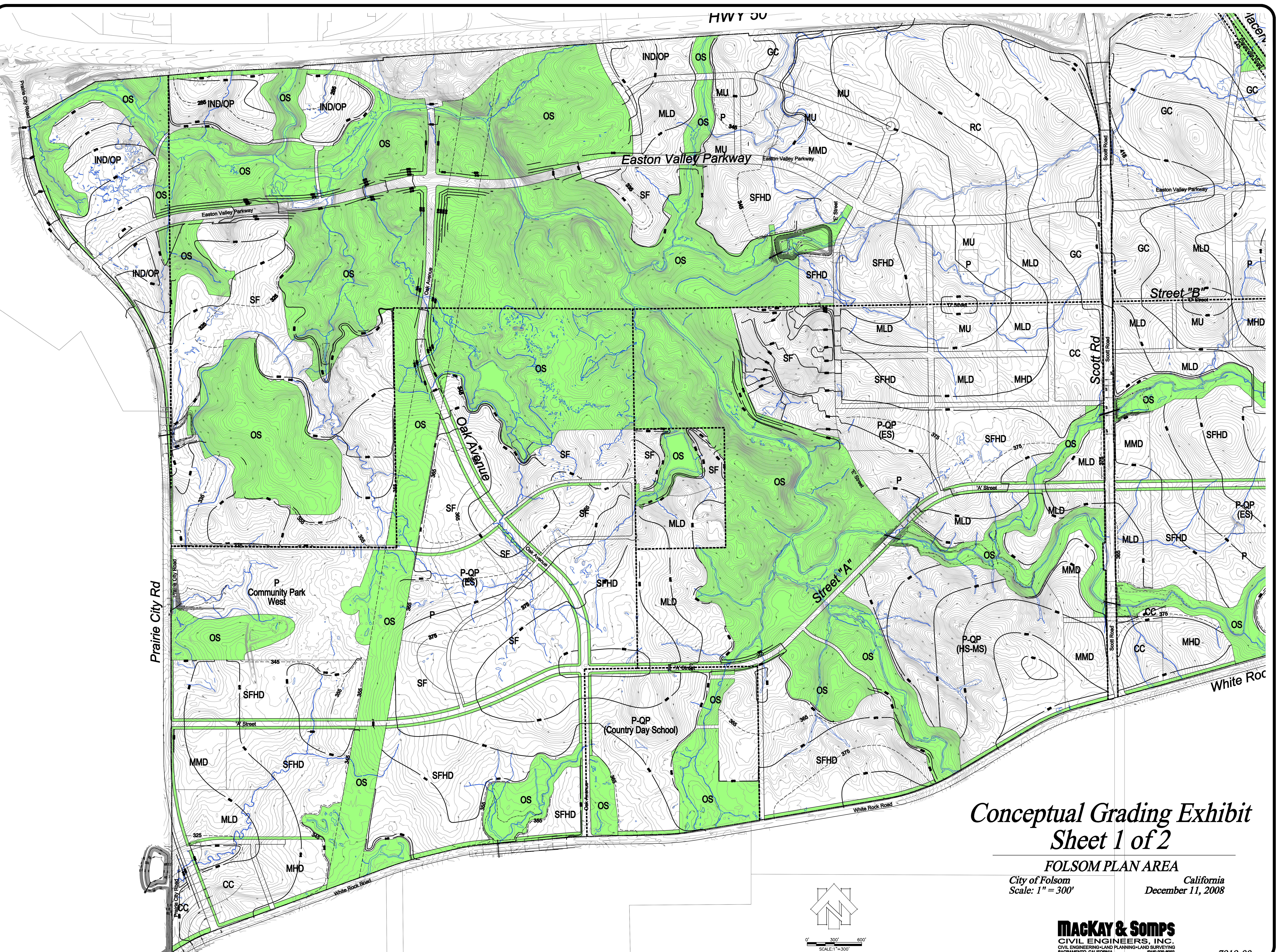

Conceptual Grading Exhibit Sheet 1 of 2

FOLSOM PLAN AREA
 City of Folsom California
 Scale: 1" = 300'
 December 11, 2008

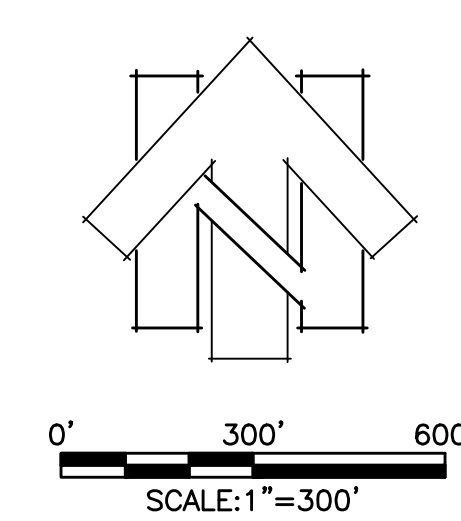

MACKEY & SOMPS
 CIVIL ENGINEERS, INC.
 CIVIL ENGINEERING • LAND PLANNING • LAND SURVEYING
 SACRAMENTO, CALIFORNIA (916) 629-0082

7919-00

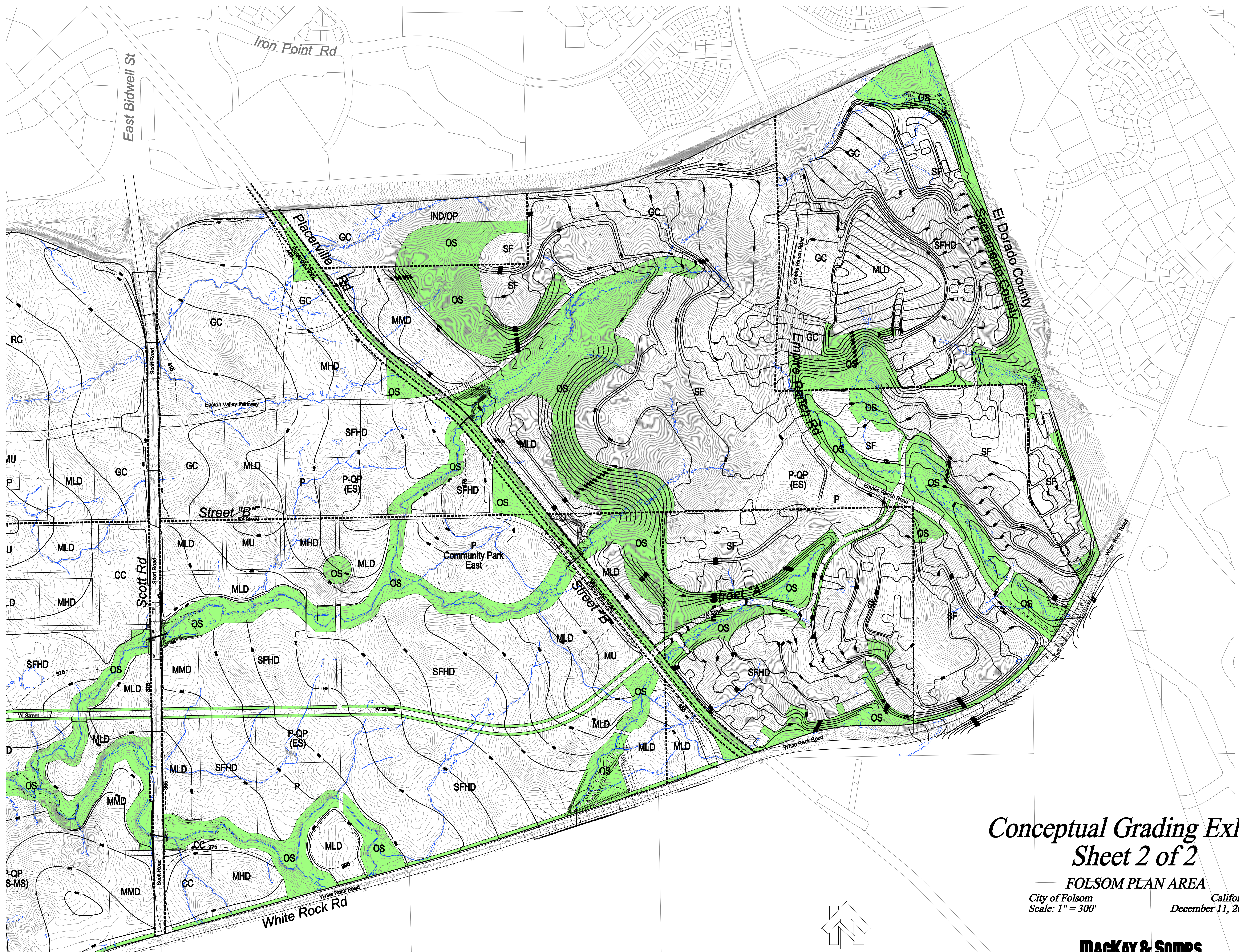

Conceptual Grading Exhibit Sheet 2 of 2

FOLSOM PLAN AREA

City of Folsom
Scale: 1" = 300'

California
December 11, 2008

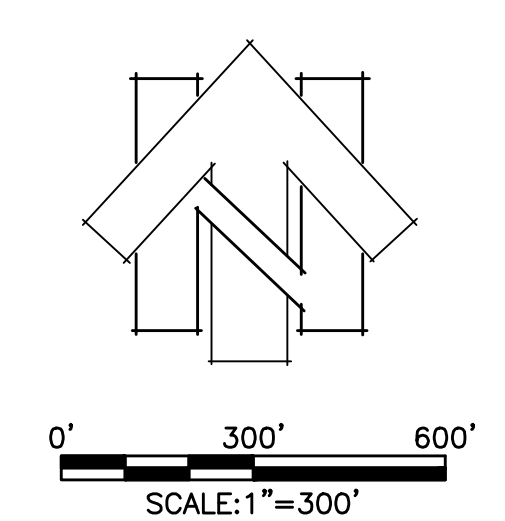

Mackay & Somps
CIVIL ENGINEERS, INC.
CIVIL ENGINEERING • LAND PLANNING • LAND SURVEYING
SACRAMENTO, CALIFORNIA (916) 828-8082