



CITY OF
FOLSOM
DISTINCTIVE BY NATURE

HISTORIC DISTRICT COMMISSION AGENDA

November 15, 2017

CITY COUNCIL CHAMBERS

5:00 p.m.

50 Natoma Street

Folsom, California 95630

CALL TO ORDER HISTORIC DISTRICT COMMISSION: Justin Raithel, Jeffrey Rempfer, John Arnaz, Mary Asay, Regina Konet, Vice Chair Candy Miller, Chair Daron Bracht

Any documents produced by the City and distributed to the Historic District Commission regarding any item on this agenda will be made available at the Community Development Counter at City Hall located at 50 Natoma Street, Folsom, California and at the table to the left as you enter the Council Chambers.

PLEDGE OF ALLEGIANCE

CITIZEN COMMUNICATION: The Historic District Commission welcomes and encourages participation in City Historic District Commission meetings, and will allow up to five minutes for expression on a non-agenda item. Matters under the jurisdiction of the Commission, and not on the posted agenda, may be addressed by the general public; however, California law prohibits the Commission from taking action on any matter which is not on the posted agenda unless it is determined to be an emergency by the Commission.

MINUTES

The minutes of September 6, 2017 will be presented for approval.

INFORMATIONAL ITEMS

1. Southern Pacific Depot Grounds Temporary Restroom Building Located at 200 Wool Street

The City of Folsom is providing a temporary restroom to be on the Southern Pacific Depot grounds at 200 Wool Street (within the Sutter Street Commercial Primary Area of the Historic District) to serve the Historic District until the Sutter Row building is constructed with permanent restrooms. **(Project Planner: Assistant Planner, Josh Kinkade)**

NEW BUSINESS

2. PN 17-345, 310 Figueroa Street - Residential Design Review and Determination that the Project is Exempt from CEQA

A Public Hearing to consider a request from Ron & Tina Edwards for approval of design review application for a 2,296-square-foot two-story single family residence located at 310 Figueroa Street. The zoning designation for the site is FIG/R-2 (The Figueroa Subarea of the Historic Residential Primary Area/Two Family Residence District) and the General Plan designation is SF (Single-Family). This project is categorically exempt from environmental review under Section 15303 of the CEQA Guidelines (New Construction or Conversion of Small Structures). **(Project Planner: Assistant Planner, Josh Kinkade / Applicant: Ron & Tina Edwards)**

PRINCIPAL PLANNER REPORT

The next Historic District Commission meeting is scheduled for **December 6, 2017**. Additional non-public hearing items may be added to the agenda; any such additions will be posted on the bulletin board in the foyer at City Hall at least 72 hours prior to the meeting. Persons having questions on any of these items can visit the Community Development Department during normal business hours (8:00 a.m. to 5:00 p.m.) at City Hall, 2nd Floor, 50 Natoma Street, Folsom, California, prior to the meeting. The phone number is 355-7222 and FAX number is 355-7274.

NOTICE REGARDING CHALLENGES TO DECISIONS

The appeal period for Historic District Commission Action: Pursuant to all applicable laws and regulations, including without limitation, California Government Code, Section 65009 and/or California Public Resources Code, Section 21177, if you wish to challenge in court any of the above decisions (regarding planning, zoning, and/or environmental decisions), you may be limited to raising only those issues you or someone else raised at the public hearing(s) described in this notice/agenda, or in written correspondence delivered to the City at, or prior to, this public hearing. Any appeal of a Historic District Commission action must be filed, in writing with the City Clerk's Office no later than ten (10) days from the date of the action pursuant to Resolution No. 8081.



CITY OF
FOLSOM
DISTINCTIVE BY NATURE

HISTORIC DISTRICT COMMISSION MINUTES
September 6, 2017
CITY COUNCIL CHAMBERS
5:00 p.m.
50 Natoma Street
Folsom, California 95630

CALL TO ORDER HISTORIC DISTRICT COMMISSION: Vice Chair Candy Miller, Justin Raitchel, Jeffrey Rempfer, John Arnaz, Mary Asay, Regina Konet, Chair Daron Bracht

ABSENT: None

CITIZEN COMMUNICATION: None

MINUTES: The minutes of August 16, 2017 were approved as submitted.

INFORMATIONAL ITEM

1. PN 17-145, Historic Sutter Street Mixed-Use Building Located at 603 Sutter Street

The information item of the proposed Historic Sutter Street Mixed-Use Building project was presented to the Commission on August 2, 2017 for purpose of gathering comments and feedback from the Commission and the public. Unfortunately, due to time constraints, the Item was continued to the September 6, 2017 Historic District Commission meeting. Subsequent to the August 2, 2017 Historic District Commission meeting, the developer informed City staff that, based on the comments and feedback received at the meeting, the proposed project is being redesigned in order to address the concerns and comments from the Commission and the residents. The developer indicated that he will be conducting a number of neighborhood outreach meetings to discuss the potential design modifications in more detail with the public.

Due to the foregoing update from the developer, staff recommends that the Chair open the Item and inform the public that (1) the project initially presented to the Commission on August 2, 2017 is being redesigned; (2) the developer is conducting neighborhood outreach meetings with the public to discuss potential design modifications; and (3) additional time is needed to make design changes. The developer is expected to be present at the September 6, 2017 meeting and can answer any questions the Commission may have.

COMMISSIONERS DISCUSSED ITEM. NO ACTION WAS TAKEN.

2. PN 17-144, Powerhouse Lofts on Sutter Project Located at 512 Sutter Street

The information item of the proposed Powerhouse Lofts on Sutter Street project was agendized for the August 2, 2017 Historic District Commission meeting but continued to the September 6, 2017 meeting due to time constraints. Subsequent to the August 2, 2017 Historic District Commission meeting, the developer informed City staff that he was in the process of redesigning the proposed project in order to address the concerns and comments that he had received thus far from the residents. The developer indicated that he will be conducting a number of neighborhood outreach meetings to discuss the potential design modifications in more detail with the public.

Due to the foregoing update from the developer, staff recommends that the Chair open the Item and inform the public that (1) the project initially described in the Staff Report for the August 2, 2017 Historic District Commission meeting is being redesigned; (2) the developer is conducting neighborhood outreach meetings with the public to discuss potential design modifications; and (3) additional time is needed to make design changes. The developer is expected to be present at the September 6, 2017 meeting and can answer any questions the Commission may have.

COMMISSIONERS DISCUSSED ITEM. NO ACTION WAS TAKEN.

PRINCIPAL PLANNER REPORT

None

There being no further business, the meeting was adjourned at 5:23pm.

Respectfully Submitted,

Amanda Palmer, Administrative Assistant

APPROVED:

DARON BRACHT, CHAIR



CITY OF
FOLSOM
DISTINCTIVE BY NATURE

Community Development Department

Date: November 15, 2017

To: Historic District Commission

From: Josh Kinkade, Assistant Planner

Subject: Southern Pacific Depot Grounds Temporary Restroom Building Located at 200 Wool Street

The City of Folsom is providing a temporary restroom building on the Southern Pacific Depot grounds at 200 Wool Street (within the Sutter Street Commercial Primary Area of the Historic District) to temporarily replace the restroom on the site that was demolished during the Sutter Street streetscape improvement project. The temporary restroom building will serve the Historic District until the Sutter Row building is constructed with permanent restrooms. Once the Sutter Row building begins construction, the temporary restroom building will be removed. The temporary restroom building will be a 156-square-foot and 11'8" tall. The City of Folsom will maintain the restroom facilities and doors will lock automatically in hours of non-operation.

Section 17.52.550(B) of the Folsom Municipal Code states that public projects are to be submitted for courtesy review and comment by the Historic District Commission. Historic District Design and Development Guidelines Policy 1.1 states that external design features, both public and private, shall be consistent with design of the time period from 1850-1950. The temporary restroom building will feature ship lap siding, cedar shingles on the gable ends of the roof, black composition shingle roofing, and a 90-square-foot covered area in front with column footings. All siding will be colored beige with brown trim. These elements are all found within the 1850-1950 era. Furthermore, the lap siding, shingles, roof material and column footings of the temporary restroom building will all be compatible with the colors and materials of the adjacent historic Southern Pacific Depot building. The site plan, floor plan, elevations (including an option for a standing seam metal roof, if desired) and images of the site are attached for reference.

Respectfully Submitted,



Pam Johns
Community Development Director

ATTACHMENT 1

Site Plan

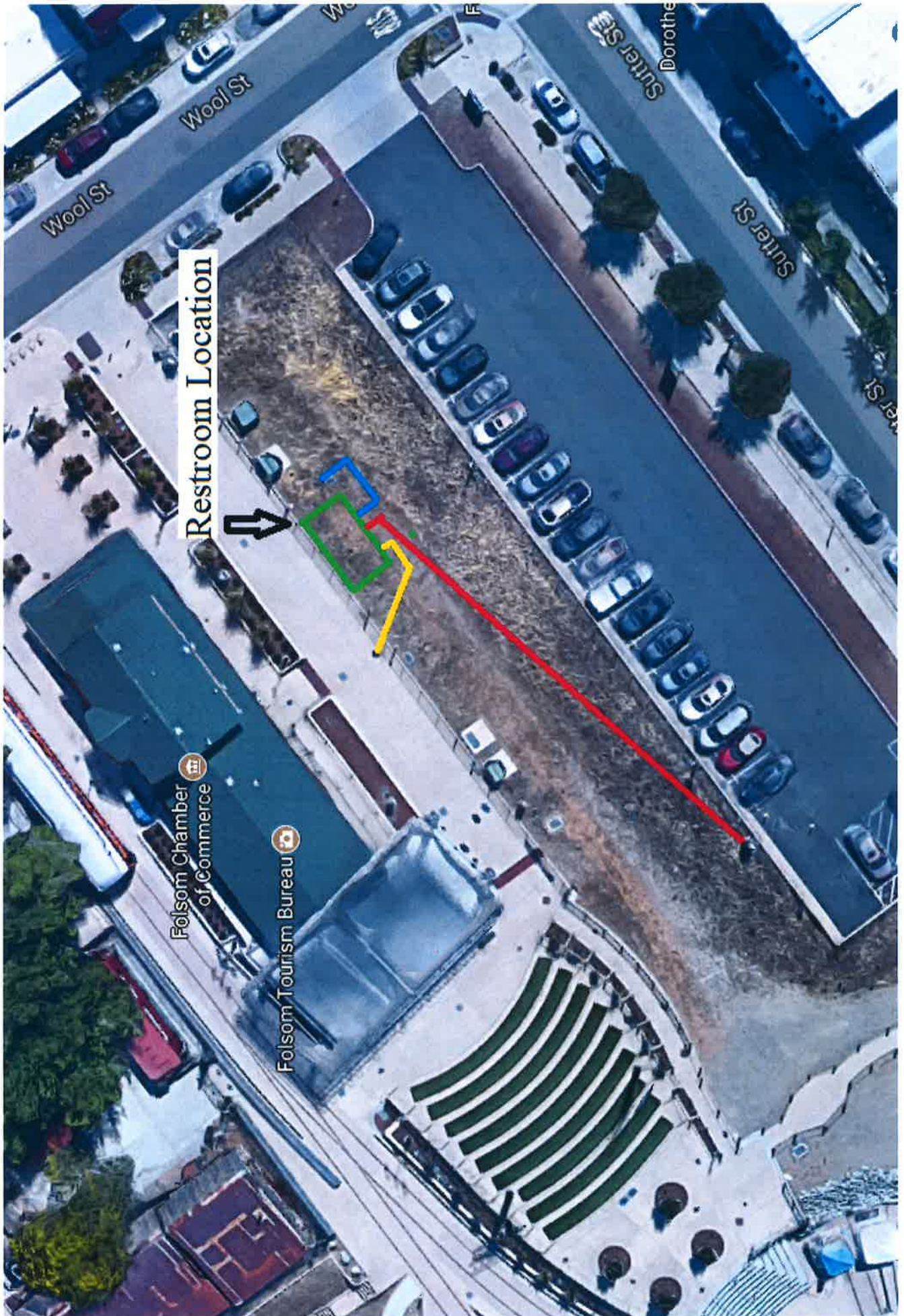

Restroom Location

Folsom Chamber of Commerce

Folsom Tourism Bureau

ATTACHMENT 2

Floor Plan, Elevations and Color Renderings,
dated October 27, 2017

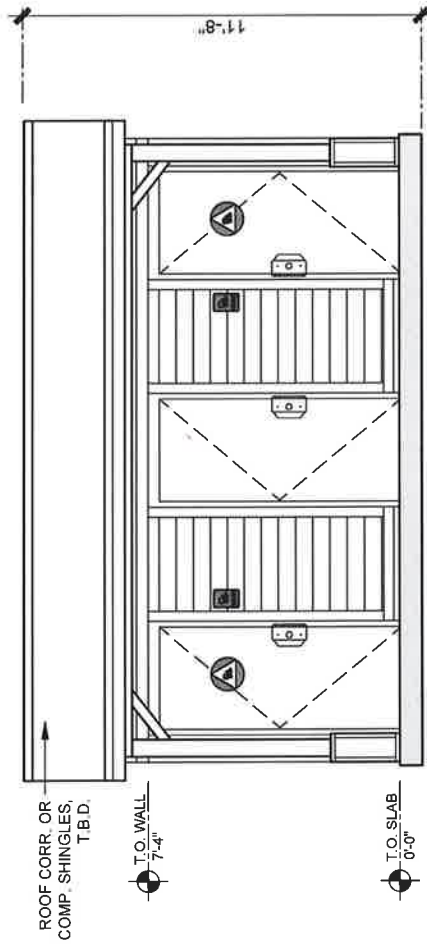

ELEVATION 1
SCALE: 3/16"=1'-0"

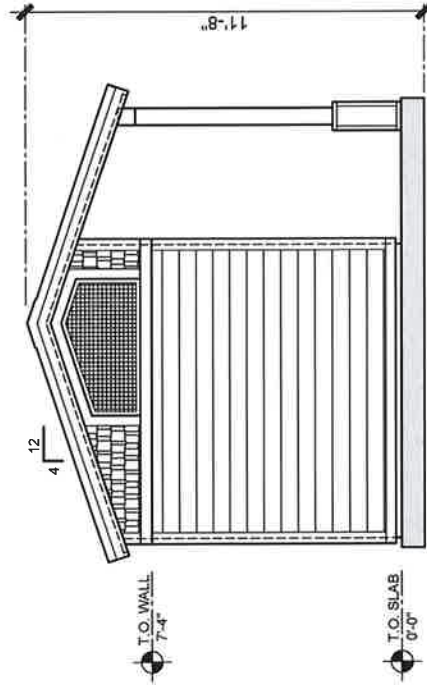

ELEVATION 2
SCALE: 3/16"=1'-0"

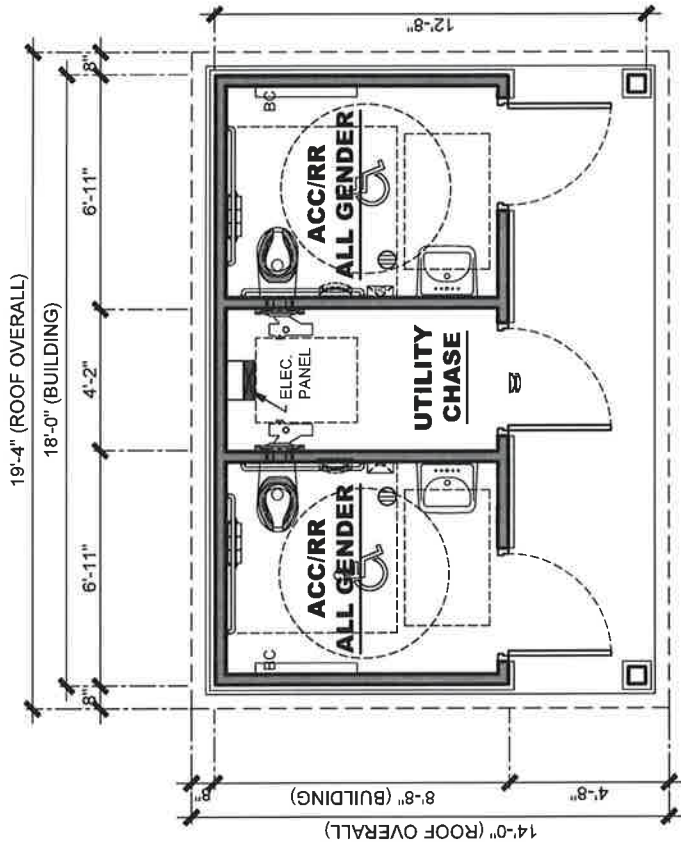

FLOOR PLAN
SCALE: 3/16"=1'-0"

W/ COLUMN BASE

 <p>PUBLIC RESTROOM COMPANY Building Better Places To Go.SM</p> <p>PH: 888-888-2060 Fax: 888-888-1448</p>	<p>BUILDING TYPE: RESTROOM BUILDING</p>		<p>REVISION # 1</p>	<p>REVISION: 10/27/2017 DATE:</p>	<p>SHEET #</p>
	<p>PROJECT: OLD TOWN FOLSOM FOLSOM, CA</p>		<p>PROJECT #: 10273</p>	<p>DRAWN BY: EOR</p>	<p>MAX. PERSON / HOUR: 90 S</p>
<p>COPYRIGHT 2017, PUBLIC RESTROOM COMPANY THIS MATERIAL IS THE EXCLUSIVE PROPERTY OF PUBLIC RESTROOM COMPANY AND SHALL NOT BE REPRODUCED, USED, OR DISCLOSED TO OTHERS EXCEPT AS AUTHORIZED BY THE WRITTEN PERMISSION OF PUBLIC RESTROOM COMPANY.</p>		<p>PRELIMINARY DESIGN DRAWING ONLY - DO NOT SCALE. DIMENSIONS PRESIDE</p>			



ROOFING: CORRUGATED

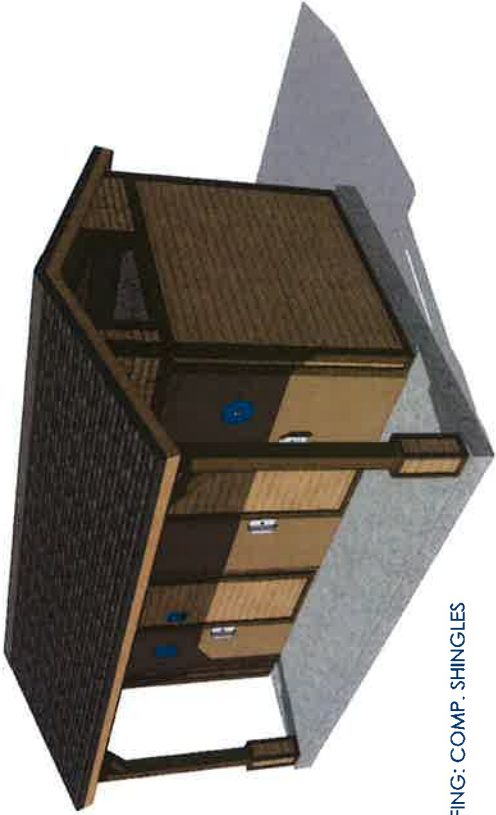

ROOFING: COMP. SHINGLES



W/ COLUMN BASE



FLOOR PLAN

SCALE: NOT TO SCALE

OLD TOWN FOLSOM

FOLSOM, CALIFORNIA

RESTROOM BUILDING

ARTIST IMPRESSION. 3D RENDERING ONLY FOR REPRESENTATION. COLORS AND MATERIALS ARE SUBJECT TO CHANGE



www.PublicRestroomCompany.com
2587 BUSINESS PARKWAY
MINDEN NEVADA 89423
P: 888-888-2040 F: 888-888-1448

COPYRIGHT 2017, PUBLIC RESTROOM COMPANY THIS MATERIAL IS THE EXCLUSIVE PROPERTY OF PUBLIC RESTROOM COMPANY AND SHALL NOT BE REPRODUCED, USED OR DISCLOSED TO OTHERS EXCEPT AS AUTHORIZED BY THE WRITTEN PERMISSION OF PUBLIC RESTROOM COMPANY.

ATTACHMENT 3

Site Photos

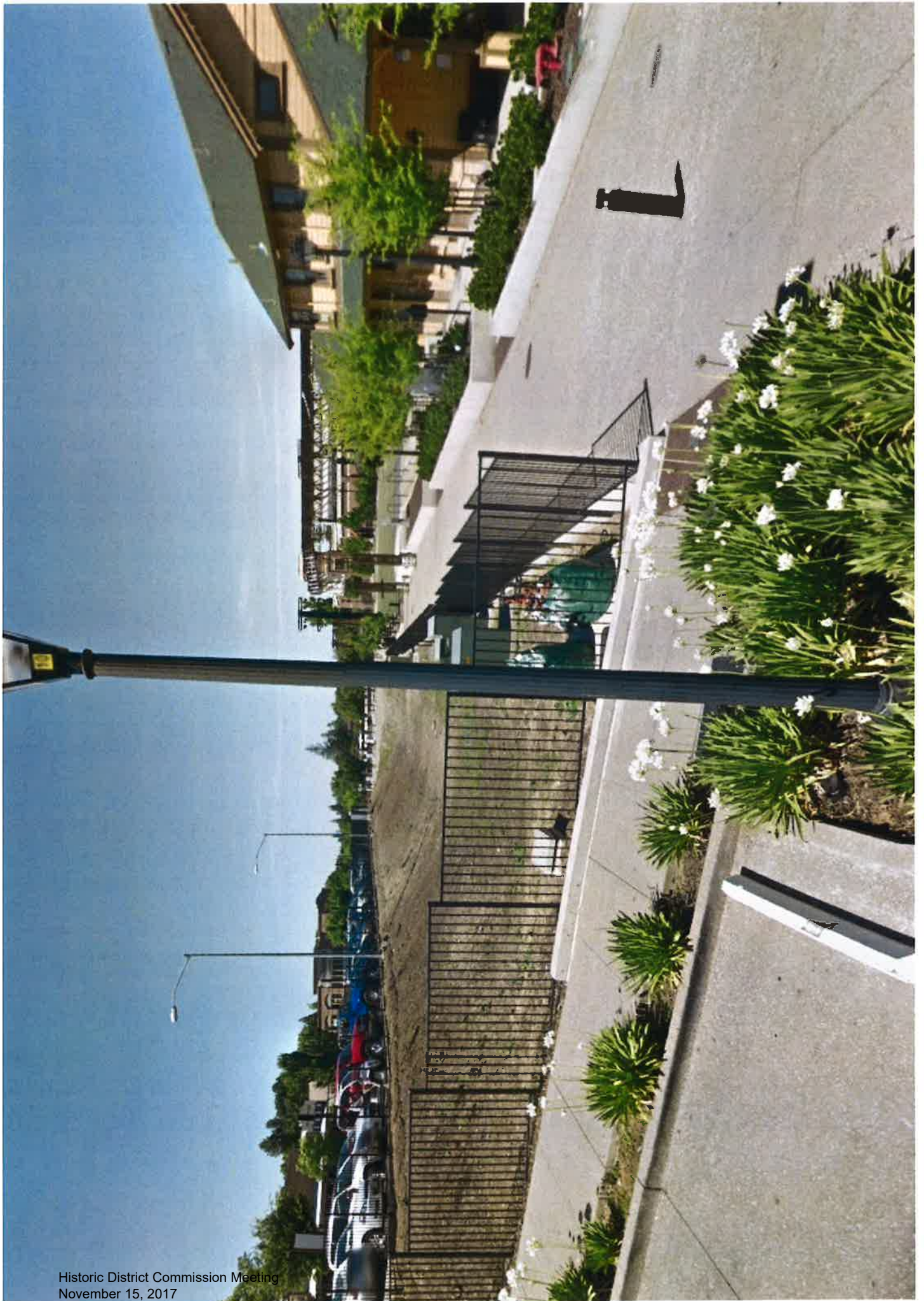



HISTORIC DISTRICT COMMISSION STAFF REPORT

PROJECT TITLE:	310 Figueroa Street Residence
PROPOSAL:	Request for design review approval of a 2,296-square-foot residence at 310 Figueroa Street and request for determination that the project is exempt from CEQA
RECOMMENDATION:	Approve, based on findings and subject to conditions
APPLICANT/OWNER:	Ron & Tina Edwards
LOCATION:	310 Figueroa Street
ASSESSOR'S PARCEL NUMBER:	070-0120-041
ZONING:	Figueroa Subarea of the Historic Residential Primary Area (FIG), with underlying zoning Two-Family Residence District (R-2)
GENERAL PLAN DESIGNATION:	Single-Family (SF)
SITE CHARACTERISTICS:	The property is flat and is covered by grass, shrubs and some oak trees.
FUTURE ACTION:	Issuance of a Building Permit and a Tree Permit
ENVIRONMENTAL REVIEW:	The project is categorically exempt from the provisions of the California Environmental Quality Act (CEQA) under Section 15303 (New Construction or Conversion of Small Structures) of the CEQA Guidelines.
ATTACHED REFERENCE MATERIAL:	<ol style="list-style-type: none">1. Vicinity Map2. Site Plan, dated September 4, 2017, Building Elevations, and Floor Plans, dated August 24, 20173. Colors and Materials, submitted October 6, 20174. Site Photos
PROJECT PLANNER:	Josh Kinkade, Assistant Planner

BACKGROUND

The 7,000-square-foot property at 310 Figueroa Street is currently undeveloped. Figueroa Street borders the property to the south, and the Sutter Street-Figueroa Street alley borders the property to the north. The project site is surrounded by single-family residences to the north, east and south and a multi-family development to the west. The subject lot is generally flat, and contains mature vegetation

(including oak trees) throughout the site. Staff did not find any records of building permit activity at this property. In 2017, the property was sold to its current owners.

PROJECT DESCRIPTION

The applicant is requesting design review approval to develop the property at 310 Figueroa Street with a 2,296-square-foot two-story single family residence. The proposed façade materials include horizontal HardiePlank lap siding colored light grey, HardiePlank window and door trim colored off-white, HardiePlank shingle roof siding colored taupe, a tumbled stone chimney and column bases, and black composition roof shingles.

Submitted drawings also show a proposed detached 990-square-foot garage with a 731-square-foot second dwelling unit above. This structure is not subject to discretionary review by the Historic District Commission. Folsom Municipal Code (FMC) Section 17.105.040 states that if an application for a second dwelling unit complies with all of the requirements of FMC Chapter 17.105- Second Dwelling Units and the project does not present any adverse impacts on any real property that is listed in the California Register of Historic Places, such an application shall only be considered ministerially by Staff without discretionary review. Staff has verified that the proposed structure complies with the requirements in Chapter 17.105 of the Folsom Municipal Code. Furthermore, the structure is located on a vacant lot, and does not present adverse impacts on any real property that is listed in the California Register of Historic Places.

PROJECT ANALYSIS

The project, which is located within the Figueroa Subarea of the Historic Residential Primary Area, has an underlying zoning designation of R-2 (Two-Family Residence District) and is designated Single-Family (SF) in the General Plan. The proposed project is subject to the development standards established within the Folsom Municipal Code Section 17.52.540, which institute requirements for lot size, lot coverage, setbacks, building height, pervious surface, and parking. The following table compares the proposed project to the development standards established by the Folsom Municipal Code for the Historic Residential Primary Area:

	<u>REQUIRED</u>	<u>PROPOSED</u>
Minimum Lot Area	7,000 sq. ft.	7,000 sq. ft.
Minimum Lot Width	50'	50'
Minimum Pervious Coverage	45% of lot area	60% of lot area
Maximum Building Height (main structure)	35'	24'
Front Yard Setback	20'	20'
Side Yard Setback	5'	5', 8'
Rear Yard Setback	20'	56'
Setback To Other Structures	8'	>8'
Minimum Parking	2 spaces	3 spaces

As shown in the table above, the proposed residence will meet all applicable development standards.

Building Design and Architecture

The project site is located within the Figueroa Subarea of the City of Folsom’s Historic District. The Figueroa Subarea is one of the four Subareas that comprise the Historic Residential Primary Area. Many of the oldest and most significant homes in Folsom, both architecturally and historically, are

concentrated in this Subarea. Given that this Subarea is readily accessible by tourists, the intent of this Subarea is to maintain pre-1910 appearance standards and provide facilities which enhance visitor and resident appreciation of the City's early residential life-style. Adherence to historic authenticity is of great importance in this Subarea.

In analyzing the architectural design of the residence, staff determined that the structures include many key elements commonly found in early residential design (pre-1910) Bungalow style, including a covered porch, lap and shingle siding, and a gabled roof with dormers. Staff has also determined that the proposed project includes the use of building materials that are natural in appearance (HardiePlank lap and shingle siding and trim, stone chimney and column bases and composition asphalt shingles) encouraged by the Historic District Design and Development Guidelines (DDG's). In addition, the proposed project utilizes colors (grey with taupe and off-white accents) which are consistent with colors typically utilized on historic residential structures.

Windows and Doors

The DDG's state that wood frame double-hung or casement windows are preferred, and that vinyl clad windows may be used for less significant structures. In general, window proportions should be vertical rather than horizontal; however, appropriate proportions and number of panes will vary depending upon the style of the individual building and the context. Regarding entries, the DDGs state that residentially-scaled and detailed solid wood or glazed doors of many styles may be appropriate. The applicant proposes vinyl double-hung windows with composite trim painted white. The windows are primary proportioned vertically. The front entrance is proposed to be a wood door with white composite trim.

Roofing

Pursuant to the DDG's Appendix D Section C.7.c, appropriate roofing materials include fireproof wood shingles, corrugated metal, composition fiberglass shingles, clay tile, or other as determined by historic evidence. Inappropriate materials consist of colored standing seam metal roofs, glazed ceramic tile or imitation roofing materials including concrete shingles and imitation concrete mission tile. The proposed roof will be a composition shingle roof colored black

Staff has determined that the overall design, colors, materials, and layout of the proposed residence is consistent with the design and development guidelines for the Figueroa Subarea of the Historic Residential Primary Area. Staff has concluded that the applicant has met the design standards identified in the Historic District Design and Development Guidelines.

Parking

The FMC Section 17.52.540 requires two parking spaces for each single-family detached dwelling unit within the Residential Primary Area of the Historic District. Required parking spaces must be provided outside required front and street side yards. The applicant is proposing one off-street parking space in the side of the lot in the rear of the residence, accessible via Figueroa Street, and two parking spaces in the rear of the lot, accessible via the alley (inside the proposed garage). Based on this, staff has determined that the proposal complies with the parking requirements.

Tree Preservation

The project site includes four oak trees with canopies that extend into the parcel, two of which with trunks on the property. The City of Folsom Tree Preservation Ordinance (FMC Chapter 12.16) regulates both the removal of protected trees and the encroachment of construction activities within their drip lines. Protected trees include native oak trees with a trunk diameter of 6 inches or greater, and multiple-trunked oak trees with an aggregate trunk diameter of 20 inches. Development on the

project site will require an arborist report to identify the protected trees on the project site. Mitigation fees are required for removal or encroachment into the Tree Protection Zone of a protected oak of more than 20 percent. Condition No. 11 is included to reflect these requirements.

ENVIRONMENTAL REVIEW

The project is categorically exempt from the provisions of the California Environmental Quality Act (CEQA) under Section 15303 (New Construction or Conversion of Small Structures) of the CEQA Guidelines.

RECOMMENDATION / HISTORIC DISTRICT COMMISSION ACTION

MOVE TO APPROVE PN17-345, DESIGN REVIEW FOR A 2,296-SQUARE-FOOT SINGLE-FAMILY RESIDENCE LOCATED AT 310 FIGUEROA STREET AND DETERMINATION THAT THE PROJECT IS EXEMPT FROM CEQA, AS ILLUSTRATED ON ATTACHMENTS 2 AND 3, WITH THE FOLLOWING FINDINGS AND CONDITIONS OF APPROVAL (NOS. 1-13):

GENERAL PROJECT FINDINGS

- A. NOTICE OF HEARING HAS BEEN GIVEN AT THE TIME AND IN THE MANNER REQUIRED BY STATE LAW AND CITY CODE.
- B. THE PROJECT IS CONSISTENT WITH THE GENERAL PLAN AND ZONING CODE OF THE CITY.

CEQA FINDING

- C. THE PROJECT IS CATEGORICALLY EXEMPT UNDER SECTION 15303 (NEW CONSTRUCTION OR CONVERSION OF SMALL STRUCTURES) OF THE CEQA GUIDELINES.

DESIGN REVIEW FINDINGS

- D. MATERIALS, TEXTURES AND COLORS USED IN THE PROPOSED PROJECT ARE COMPATIBLE WITH SURROUNDING DEVELOPMENT AND ARE CONSISTENT WITH THE GENERAL DESIGN THEME OF THE NEIGHBORHOOD.
- E. THE PROPOSED PROJECT IS IN CONFORMANCE WITH THE HISTORIC DISTRICT DESIGN AND DEVELOPMENT GUIDELINES ADOPTED BY CITY COUNCIL.

Submitted,



PAM JOHNS
Community Development Director

CONDITIONS OF APPROVAL

1. Compliance with all local, state and federal regulations pertaining to building is required.
2. The applicant shall submit a Building Permit Application to the Community Development Department for its review and approval that shall substantially conform to the items referenced below:
 - a) Site Plan, Dated September 4, 2017, Building Elevations, and Floor Plans, dated August 24, 2017
 - b) Colors and Materials, submitted October 6, 2017
3. A Building Permit shall be issued on the project within one year of the date of this approval (November 15, 2018).
4. The proposed garage/second unit structure shall be subject to a separate staff-level review to determine conformance with FMC Chapter 17.105- Second Dwelling Units.
5. The proposed colors and siding, trim and roof materials of the residence shall match the proposed colors and materials on file with the Community Development Department.
6. Permanent fencing shall be no greater than 3 ½ feet tall in front of the residence and 6 feet tall in the side and rear of the residence.
7. A Code Compliance Letter for a certified pad shall be submitted to the Engineering Division prior to issuance of a Building Permit.
8. This project shall be subject to all applicable City-wide development impact fees.
9. The owner/applicant agrees to pay to the Folsom-Cordova Unified School District the maximum fee authorized by law for the construction and/or reconstruction of school facilities. The applicable fee shall be the fee established by the School District that is in effect at the time of the issuance of a building permit. Specifically, the owner/applicant agrees to pay any and all fees and charges and comply with any and all dedications or other requirements authorized under Section 17620 of the Education Code; Chapter 4.7 (commencing with Section 65970) of the Government Code; and Sections 65995, 65995.5 and 65995.7 of the Government Code.
10. A Landscape Plan (that complies with the state-mandated Model Water Efficient Landscape Ordinance - AB 1881) is required to be submitted prior to issuance of the Custom Home building permit, and landscaping of the front yard shall be completed prior to receipt of full Certificate of Occupancy. Alternately, an Irrigation & Landscape Permit shall be applied for, paid for and issued with the stipulation that landscape plans are submitted within 180 calendar days of the initial Irrigation & Landscape Permit issue date and completed within 1 year, with a possible 90-day extension if substantially in progress.
11. An arborist report is required which locates, identifies, assesses and quantifies each tree on the project site. A site plan showing existing trees, proposed tree removals and proposed structures is required as part of this arborist report. The arborist report and site plan shall be submitted to the Community Development Department prior to issuance of a building permit. A Tree Permit,

protection plan and appropriate mitigation may also be required to protect and/or account for the proposed development activities.

12. All Conditions of Approval as outlined herein shall be made as a note or separate sheet on the Construction Drawings.
13. If any archaeological, cultural, or historical resources or artifacts, or other features are discovered during the course of construction anywhere on the project site, work shall be suspended in that location until a qualified professional archaeologist assesses the significance of the discovery and provides consultation with the Folsom Historical Society, City staff, and the Historic Preservation League. Appropriate mitigation as recommended by the archaeologist and the Historical Society representative shall be implemented. If agreement cannot be met, the Planning Commission shall determine the appropriate implementation method.

ATTACHMENT 1

Vicinity Map

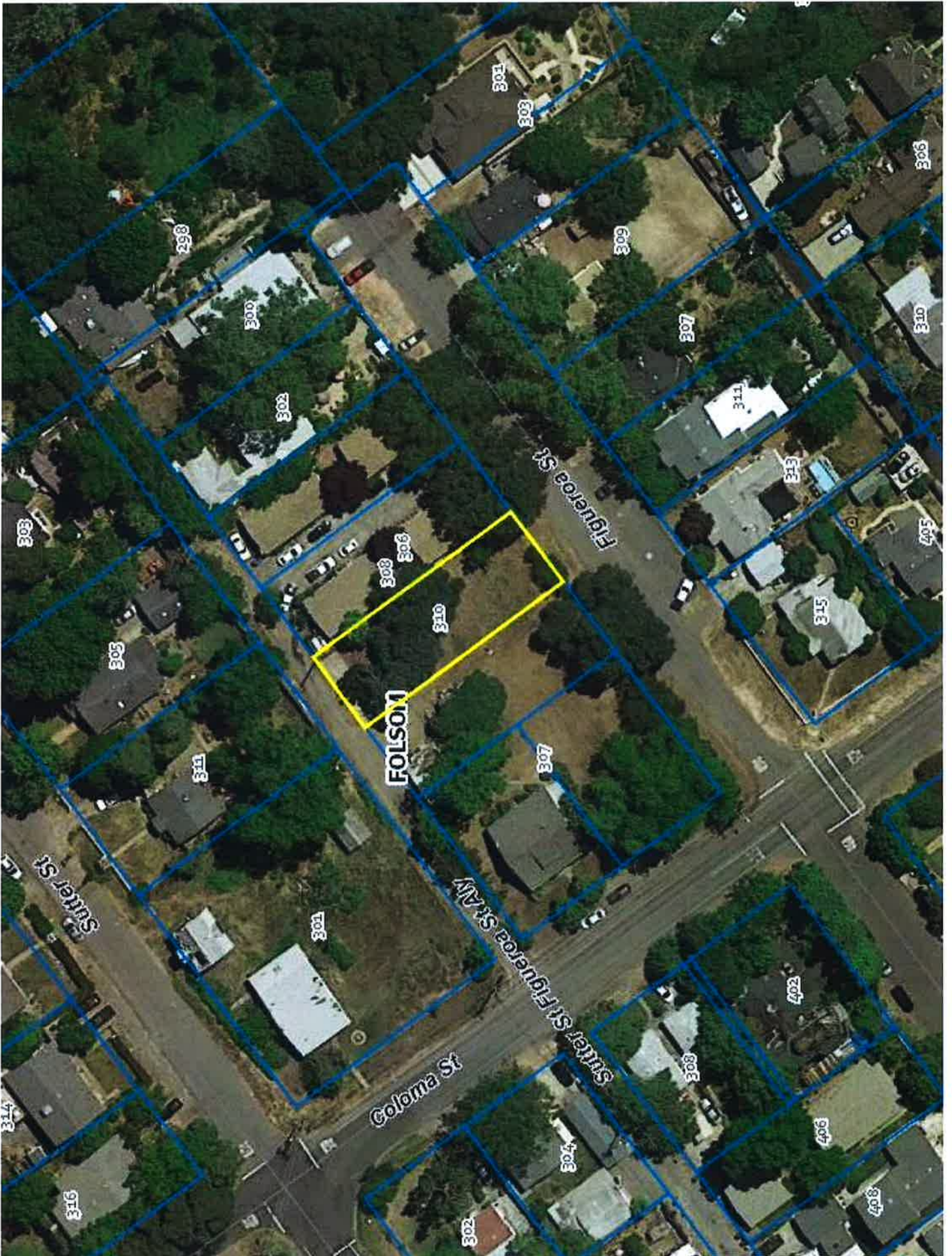

ATTACHMENT 2

Site Plan, Dated September 4, 2017, Building Elevations, and
Floor Plans, dated August 24, 2017

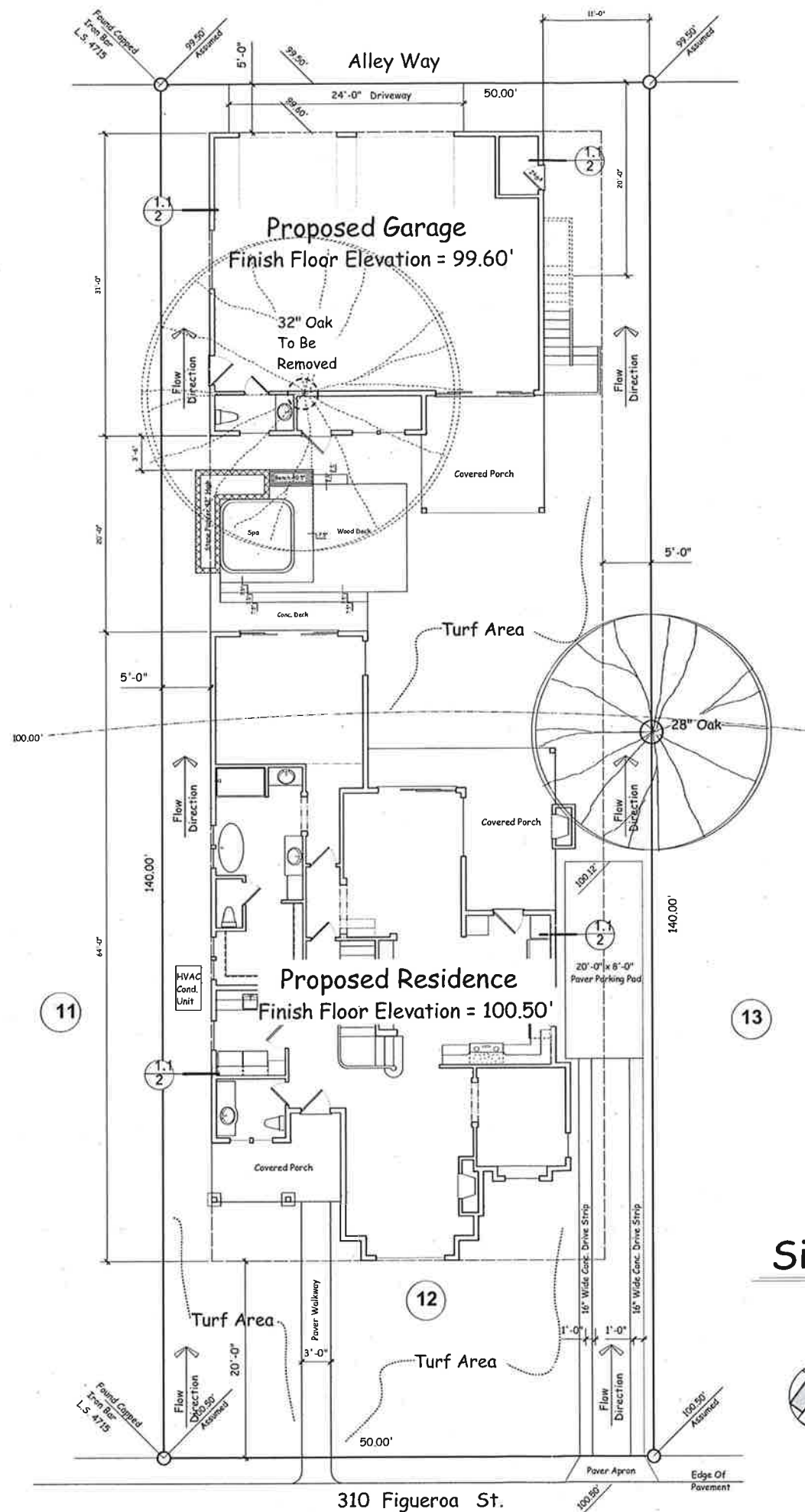

Site Plan

3/16" = 1'-0"



Site Plan Legend

- Property Lines & Corners
- Setback Lines
- Contour Lines
- Subd. Lot #
- Flow Direction
- Swale Or Drainage Flow
- Straw Waddle or Silt Fence Per CalGreen Stormwater Management Plan 4.106.2

Existing Site Conditions Are Assumed, Contractor To Site Verify.

Legal Description

310 Figueroa St.
 Folsom, Ca. 95630
 A.P.N. 070-0120-041-0000
 Lot 12 Block 31,
 Map of the Town of Folsom

Project Specific's

Max. Height = 35'-0"
 Lot Sq. Ft. = 7,000 Sq. Ft.
 Allowable Coverage = 60% = 4,200 Sq. Ft.

Proposed House =	1588 Sq. Ft.
Proposed Garage =	1040 Sq. Ft.
Proposed Covered Porches =	432 Sq. Ft.
Proposed Driveway =	120 Sq. Ft.
Proposed Spa Deck =	319 Sq. Ft.
Proposed Drive Strips =	115 Sq. Ft.
Proposed Parking Pad =	160 Sq. Ft.
Proposed Walkway =	78 Sq. Ft.
Impervious Coverage Total =	3854 Sq. Ft.
Total Coverage =	55%

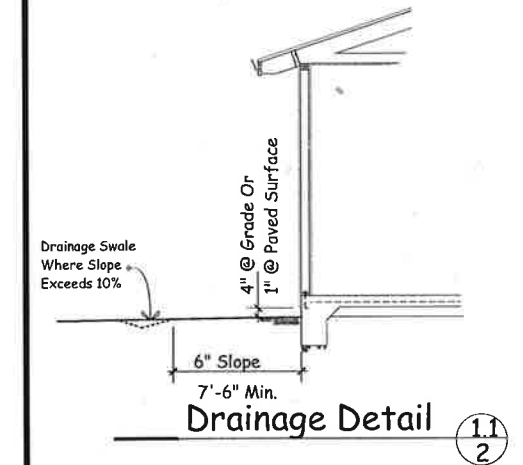

Plan Preparation

Folsom Designs
 301 Natoma St. # 105
 Folsom, Ca. 95630
 (916) 351-1400 Ph.

David Fischer
 9-4-17
 Signature Date

Project Location :
 310 Figueroa St.
 Folsom, CA 95630
 APN 070-0120-041-0000

A Residence For:
 Ron & Tina Edwards
 2300 Iron Point Rd. # 2414
 Folsom, CA 95630

JOB #	817-06
DATE	9/4/17
SCALE	Noted
DRWN BY	DBF
APPR BY	
REVISIONS	DATE

SHEET
2
 OF SHEETS



Plan Preparation

Folsom Designs
301 Natoma St. # 105
Folsom, Ca. 95630
(916) 351-1400 Ph.

David Fischer
8-26-17
Signature Date

Project Location :
310 Figeuroa St.
Folsom, CA 95630
APN 070-0120-041-0000

A Residence For:
Ron & Tina Edwards
2300 Iron Point Rd. # 2414
Folsom, CA 95630

JOB #	817-06
DATE	8/24/17
SCALE	Noted
DRWN BY	DBF
APPR BY	
REVISIONS	DATE

SHEET
A3
OF SHEETS

Exterior Materials

- 301 ... 50 Year Dimensional Comp. Shingles
- 302 ... 1" x 12" Hardie Trim Fascia Board W/ 5" Gutters W/ Leaf & Debris Accumulation Guard
- 303 ... 3"x2" Sht. Mtl. Down Spouts, Paint To Match House & Connect To Landscape Drain Pipe
- 304 ... 1" x 12" Hardie Trim Barge Board & 1" x 6" Barge Trim Bd.
- 305 ... 1"x8" Hardie Trim Band
- 306 ... Hardie Plank 5" Lap Siding
- 307 ... Hardie Shingle Siding, Staggered Edge Panel
- 308 ... 1"x4" Hardie Trim, Windows & Doors
- 309 ... 1"x4" Hardie Trim @ Corners
- 310 ... El Dorado Stone Veneer W/ Sill Trim
- 311 ... 6"x12" Shaped Wood Diagonal Braces
- 312 ... 6"x10" Wood Shaped Corbels
- 313 ... Arch Louvered Gable End Vent.
- 314 ... Sheet Metal Chimney Cap
- 315 ... Sheet Metal Flashing Typ @ All Valley & Wall to Roof Locations, All Sht. Mtl. To Be Painted to Match Body Color of Roof

Roofing Underlayment

- Pitch From 4:12 Or Greater :
- Underlayment material shall conform to ASTM D 226, D 1970, D4869, Or D 6757.
 - One layer applied shingle fashion, parallel to and starting from the eave and lapping 2 inches, End laps shall be offset 6 feet. Fasteners per 2016 CRC R905.1.1

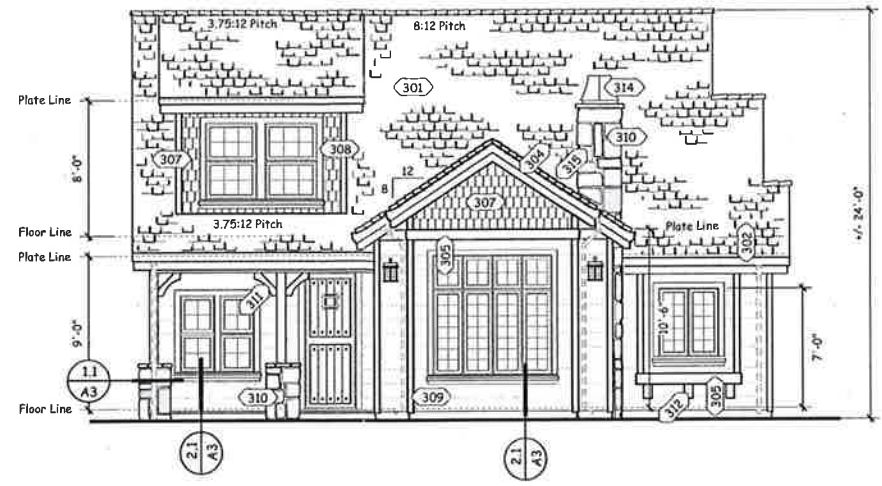
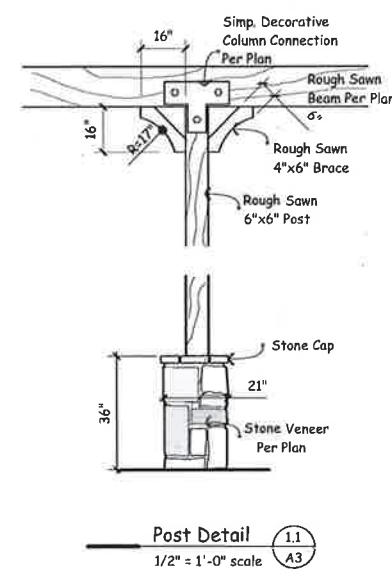
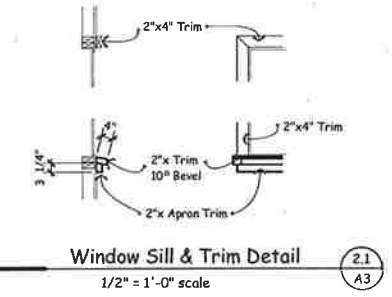

Front Elevation
1/4" = 1' 0" (South Wall)

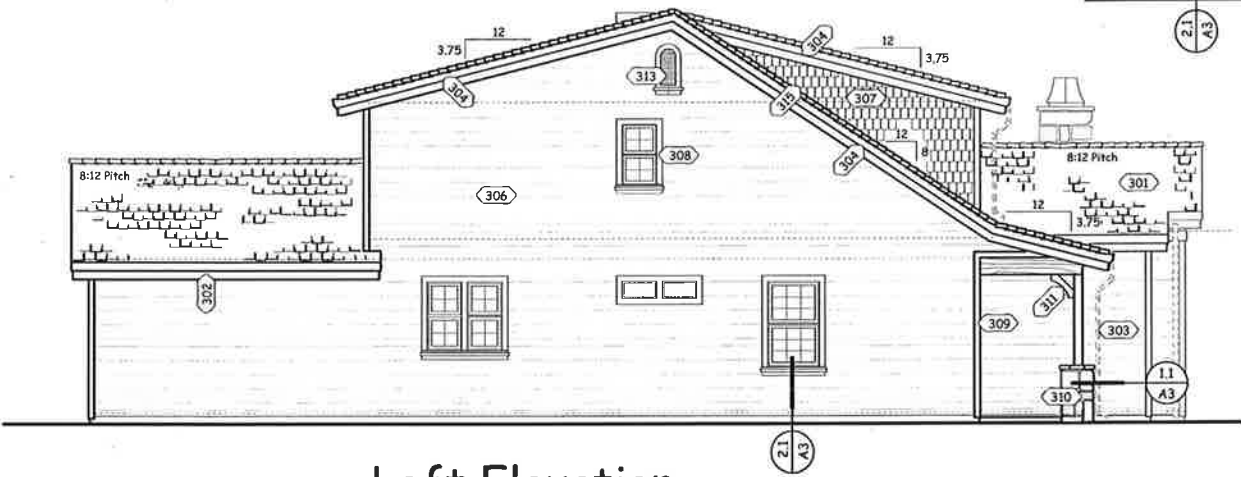

Left Elevation
1/4" = 1' 0" (West Wall)

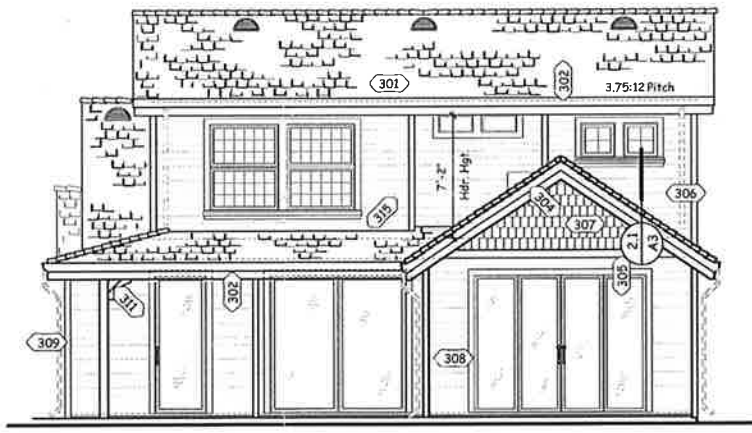

Rear Elevation
1/4" = 1' 0" (North Wall)

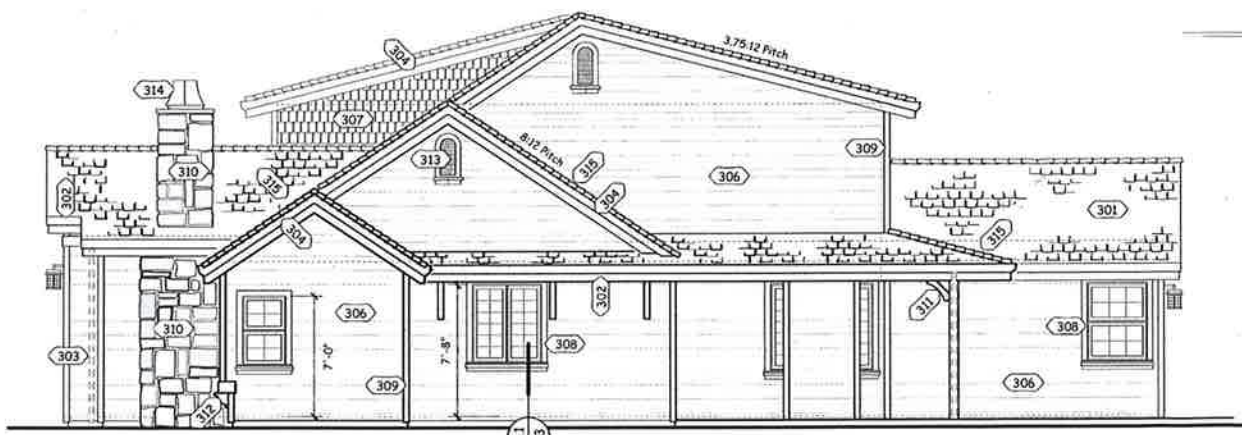

Right Elevation
1/4" = 1' 0" (East Wall)

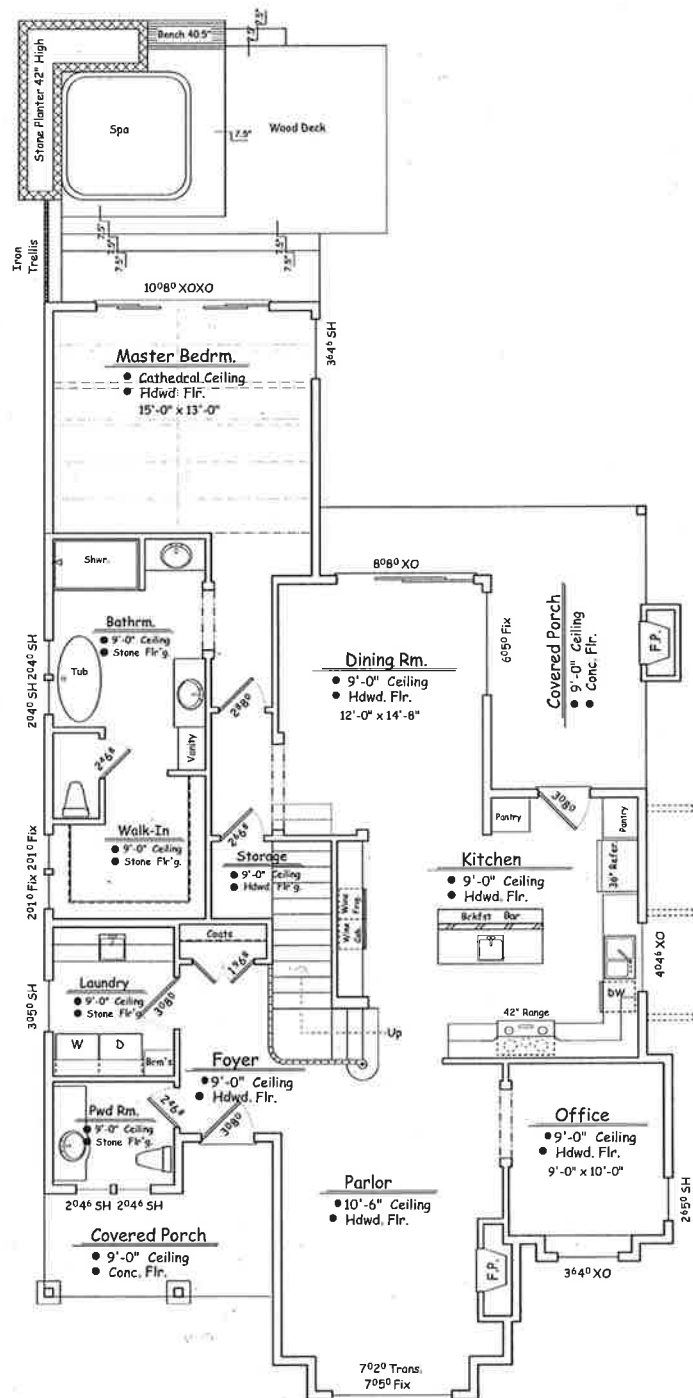

Main Floor Plan

1/4" = 1' 0" (1594 Sq. Ft. 1st Flr. Living)
 (702 Sq. Ft. 2nd Flr. Living)
 (2296 Sq. Ft. Total Living)
 (286 Sq. Ft. 1st Flr. Cvr'd Porch & Patios)



Legend

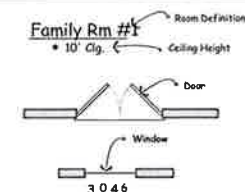

Window Abrev.

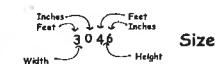

Label	Operation
SH	Single Hung
XO	Horizontal Slider
Fix	Fixed
Temp. Gls.	Tempered Glass

Wall Legend



Plan Preparation

Folsom Designs
 301 Natoma St. # 105
 Folsom, Ca. 95630
 (916) 351-1400 Ph.

David Fischer
 8-26-17
 Signature Date

Project Location :
 310 Figeuroa St.
 Folsom, CA 95630
 APN 070-0120-041-0000

A Residence For:
 Ron & Tina Edwards
 2300 Iron Point Rd. # 2414
 Folsom, CA 95630

JOB #	817-06
DATE	8/24/17
SCALE	Noted
DRWN BY	DBF
APPR BY	
REVISIONS	DATE



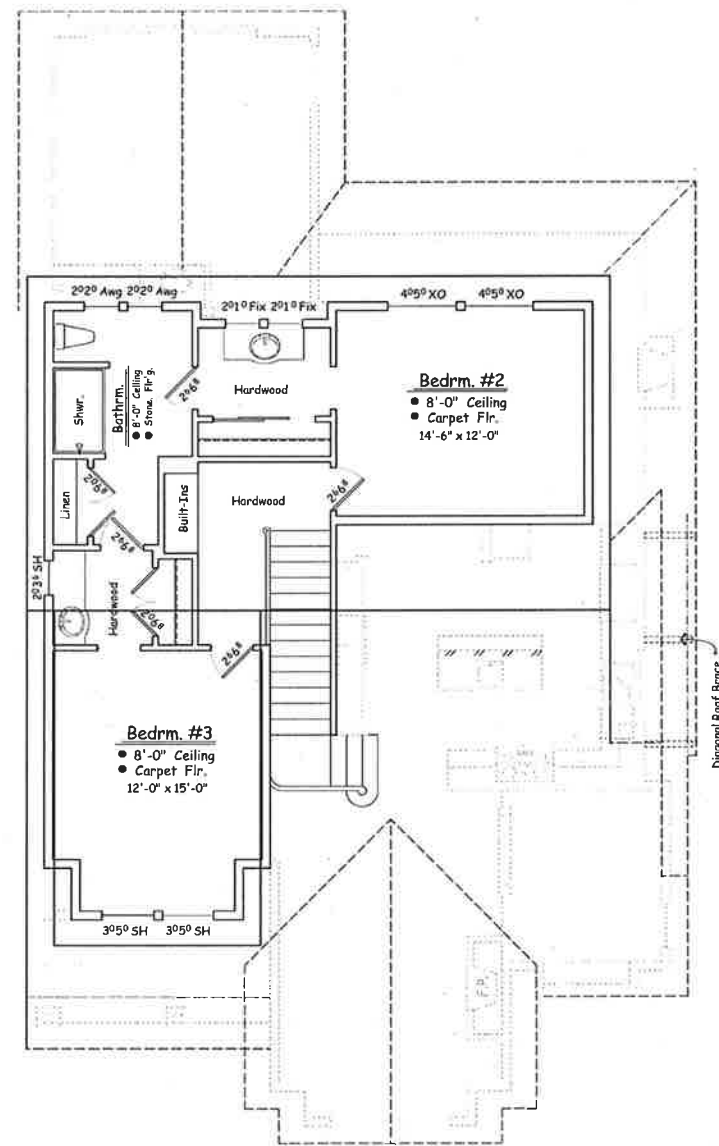

Upper Floor Plan

1/4" = 1' 0" (702 Sq. Ft. Living)



Legend

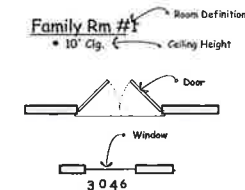

Window Abrev.

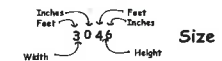

Label	Operation
SH	Single Hung
XO	Horizontal Slider
Fix	Fixed
Temp. Gl.	Tempered Glass

Wall Legend

	Bearing 2"x6" @ 16" O/C
	Non-Bearing 2"x4" @ 16" O/C



Plan Preparation

Folsom Designs
301 Natoma St. # 105
Folsom, Ca 95630
(916) 351-1400 Ph.

David Fischer
8-26-17
Signature Date

Project Location :
310 Figeuroa St.
Folsom, CA 95630
APN 070-0120-041-0000

A Residence For:
Ron & Tina Edwards
2300 Iron Point Rd. # 2414
Folsom, CA 95630

JOB #	817-06
DATE	8/24/17
SCALE	Noted
DRWN BY	DBF
APPR BY	
REVISIONS	DATE

SHEET
A5
OF SHEETS

ATTACHMENT 3

Colors and Materials, Submitted October 6, 2017

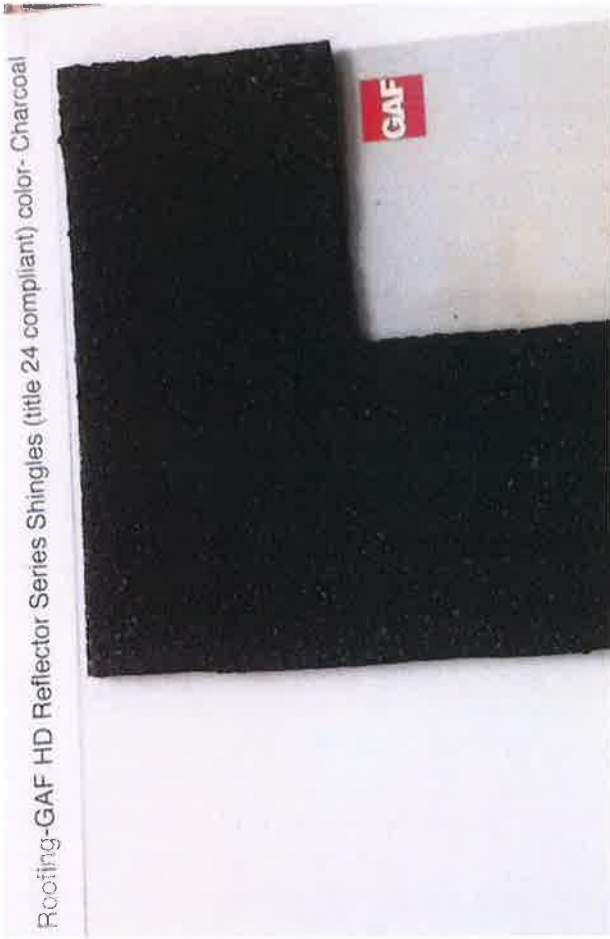

HardiePlank 5 1/2 in. Lap Siding-Pearl Gray

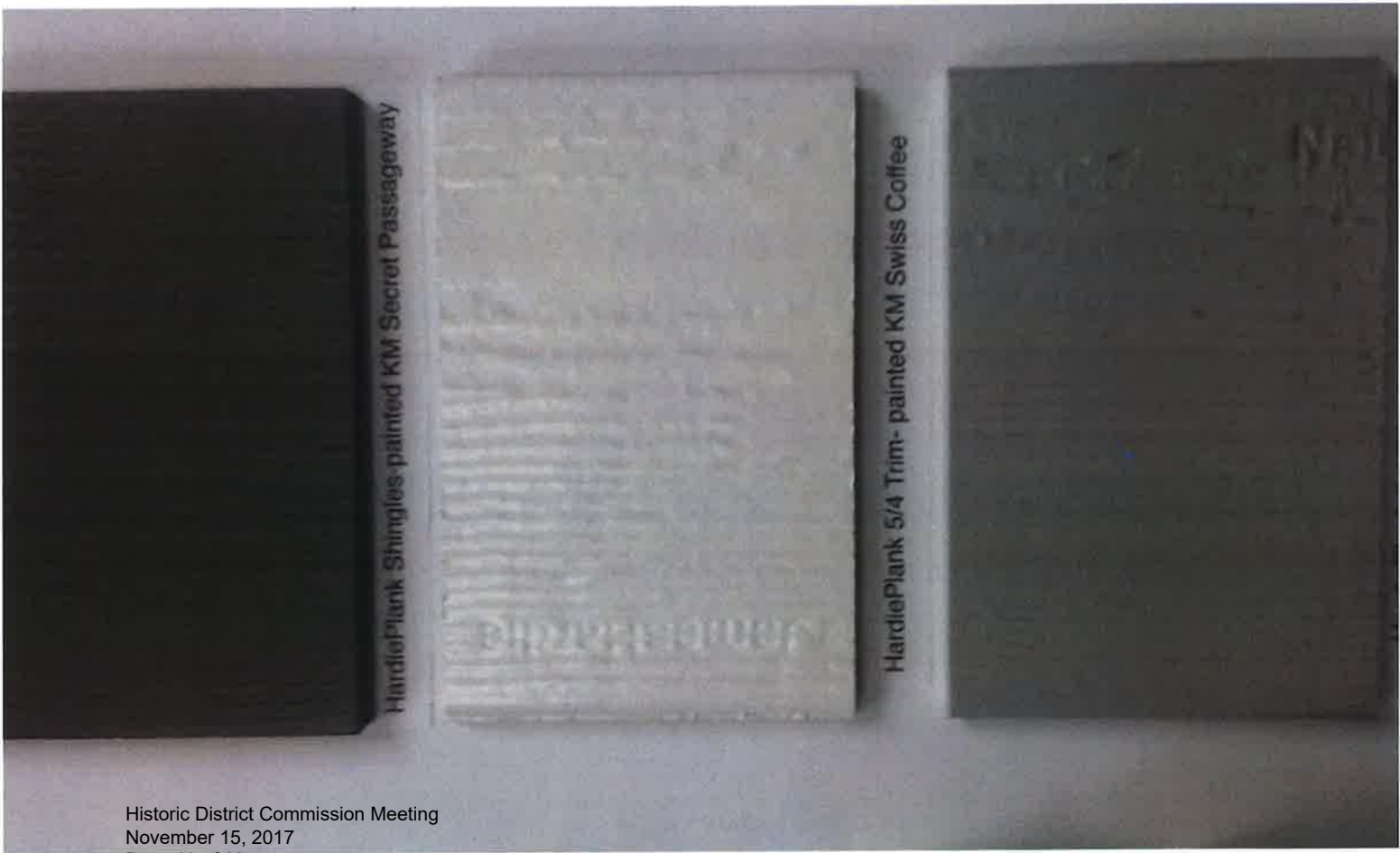

ATTACHMENT 4

Site Photos

